

Design and fabrication of a passive irradiation module utilizing the high neutron flux from the 5 MW Spallation Source at ESS

Yongjoong Lee

On behalf of

Federico Masi, Marc Kickulies, Yannick Bessler, Luca Zanini

www.europeanspallationsource.se

16-11-14

The System Purposes

- Irradiate the materials of scientific and operational interests by high flux protons and neutrons, for the study of radiation induced degradation:
 - Study of the irradiated materials, which make the structural components of ESS target station systems, for longer lifetime and higher reliability.
 - Perform fundamental research on the irradiated materials, in the framework of international collaboration, for example, on fusion materials, etc.

Potential Locations

1. STIP type module in the target wheel
2. FMITS type module in the beam upstream zone of the target wheel
3. IFMIF type module integrated into the pre-moderator

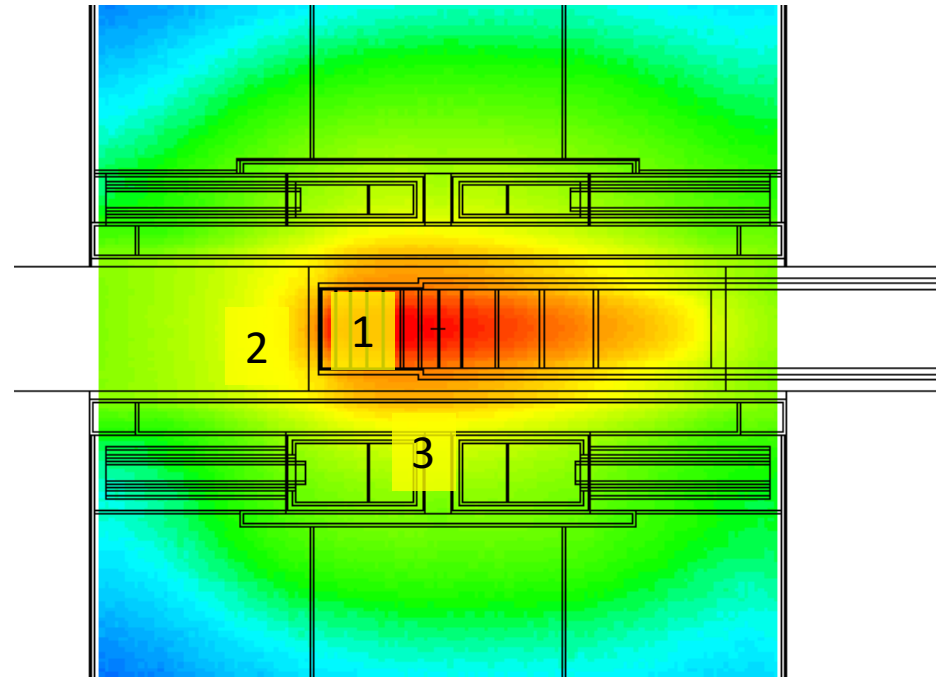

Irradiation Module in Target Wheel

- A passive irradiation module at the place of tungsten block
 - No irradiation temperature control
- Mostly fast proton and neutron irradiation
 - High gas production rate
- Minute design interface
- Low damage rate: ($\sim O(1)$ dpa/year)

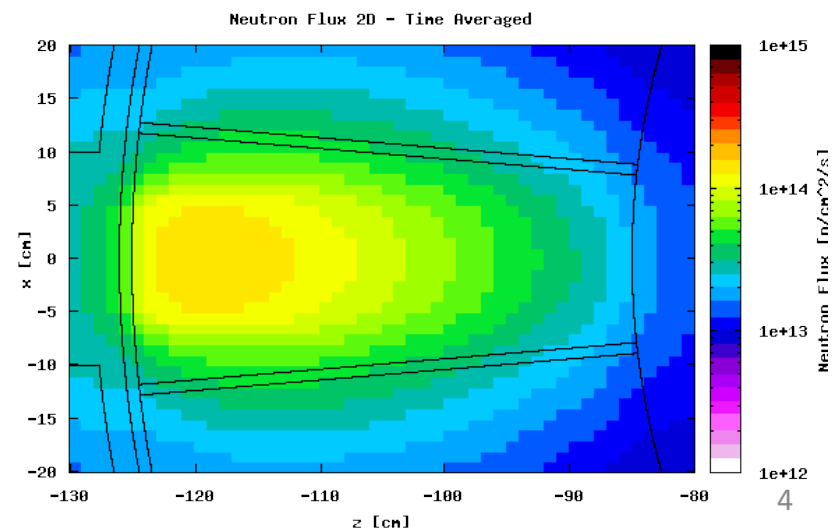
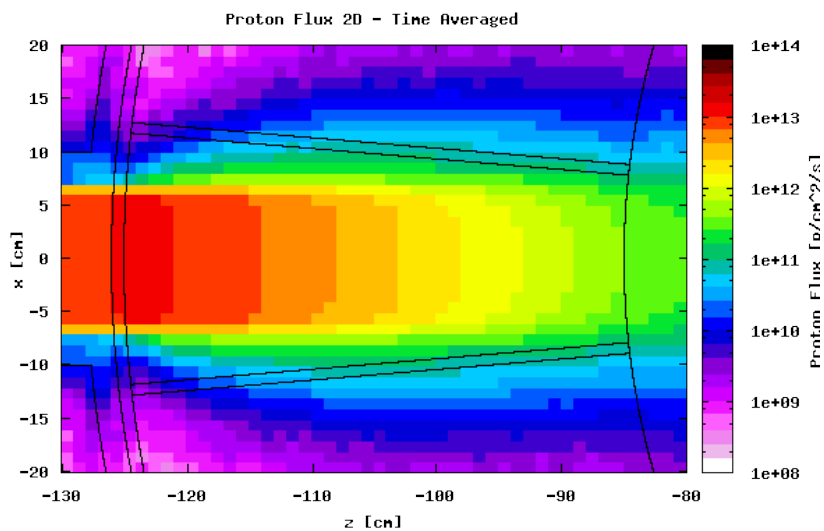
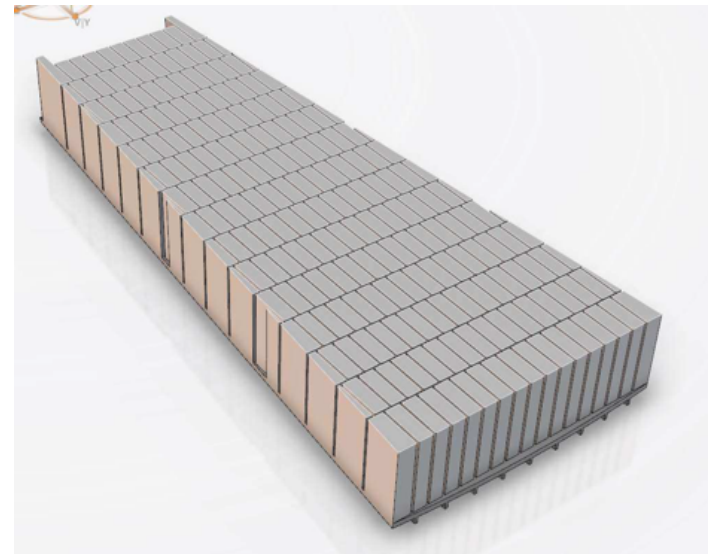

Irradiation Module in Beam Upstream

- Damage rate from 3 dpa/year to 6 dpa/year can be achieved
- He-appm/dpa can be controlled to be below 20
 - The precision of proton beam aperture is an issue
- Larger available irradiation volume
- Medium design interface to MR system
- Small neutronic impact

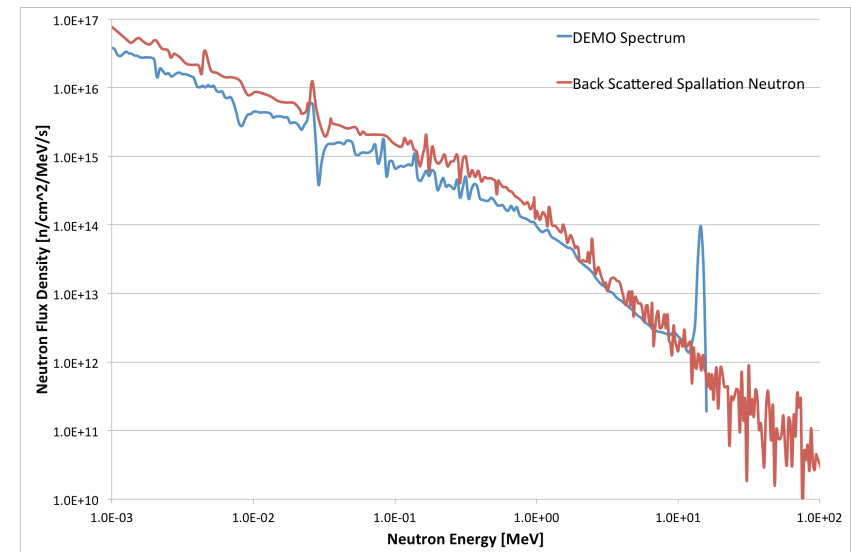
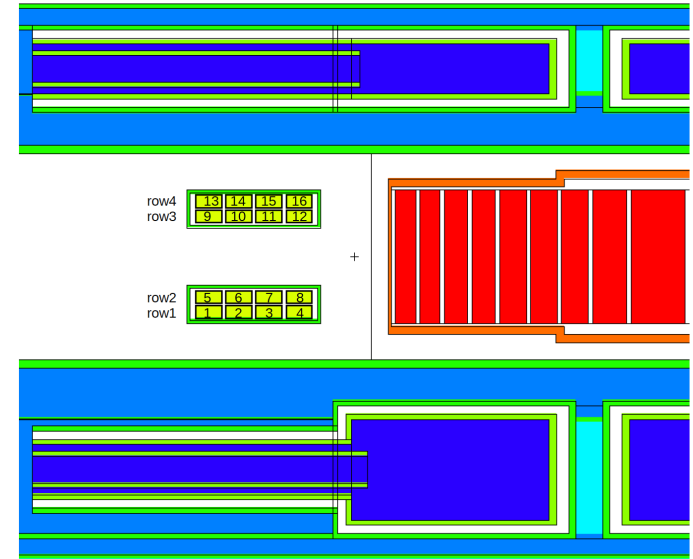

Irradiation Module in Pre-Moderator

- Highest DPA rate of up to 12.5 DPA/GW-d
- He-appm/dpa ratio ranges from 11 to 17
- 15 cc Irradiation volume per module for > 10 DPA/GW-d
- 30 cc Irradiation volume per module for > 6 DPA/GW-d
- Neutronic penalty up to 3% per module, for affected beamline

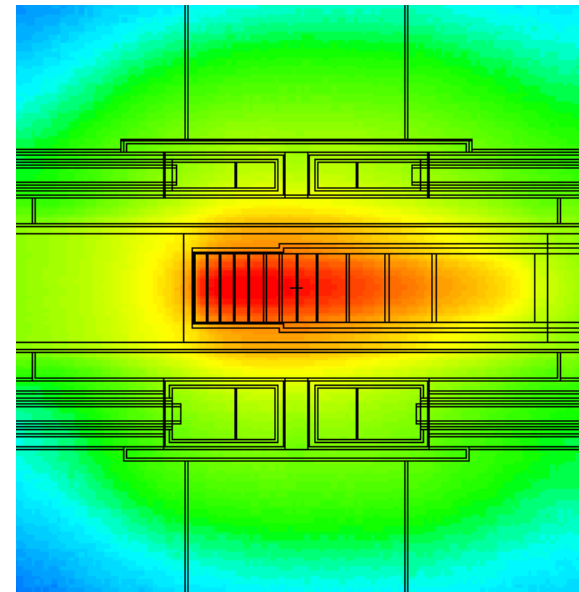
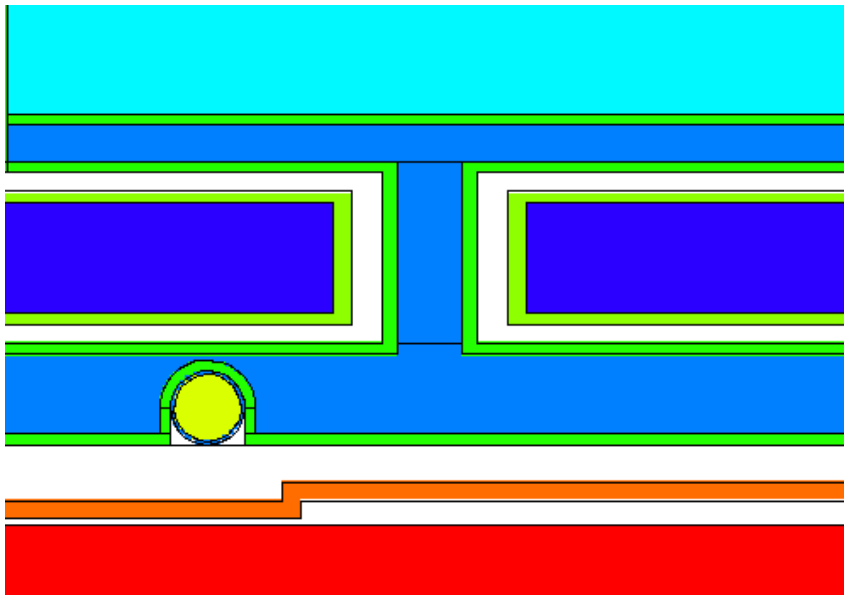

Balance Sheet from Fusion Materials Application Viewpoint

	Module in the Target Wheel	Module in the Moderator	Module in the Upstream
Max Damage Rate	~1 DPA/year	> 12 DPA/year	~6 DPA/year
He-appm/DPA	> 20	13	< 20
Temperature control	Passive	Active	Active
Neutronic Penalty	< 1%/module	~2%/module	0%
Irradiation Volume	~20 cc/module	~30 cc/module	~30 cc/module
Number of modules	1 - 108	1 - 6	1 - 8
Design interface	small	large	medium
Development Cost	~0.1 MEUR/module	~1.0 MEUR/module	~0.5 MEUR/module
Application for ESS	Spallation materials, structural materials for target wheel and monolith	Structural materials for target shell, MR vessel and monolith	Structural materials for target shell, MR vessel and monolith

ESS Spallation Neutron Irradiation Program (**ESNIP**): Module in Moderator



- ESNIP-I (2019-2024)
 - Proof of Concept Module
 - Passively cooled by pre-moderator water flow
- ESNIP-II (2024 and on): Vision
 - Located at the hot spot position for optimal damage dose
 - Irradiation module with active temperature control
 - Larger Irradiation Volume

Passive Irradiation Module: ESNIP-I

- Passive module beam downstream region
 - The module operates in a parasitic mode
 - Flow condition is better defined in the flow inlet region
 - Reduced risk of flow channel blockage

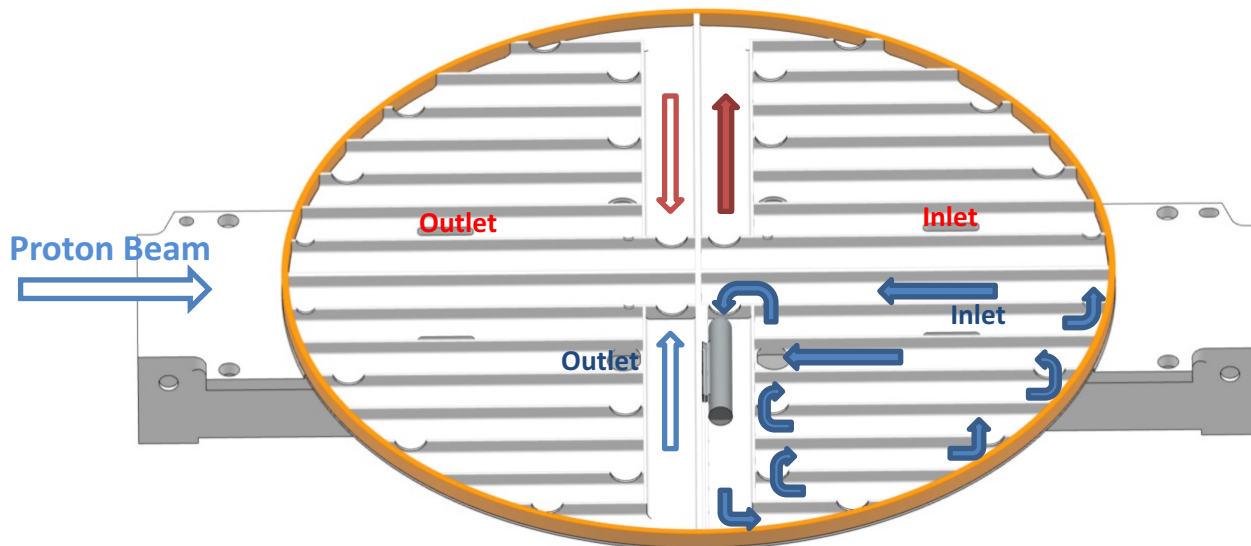

Initial Operation: Proton beam ramp-up and damage

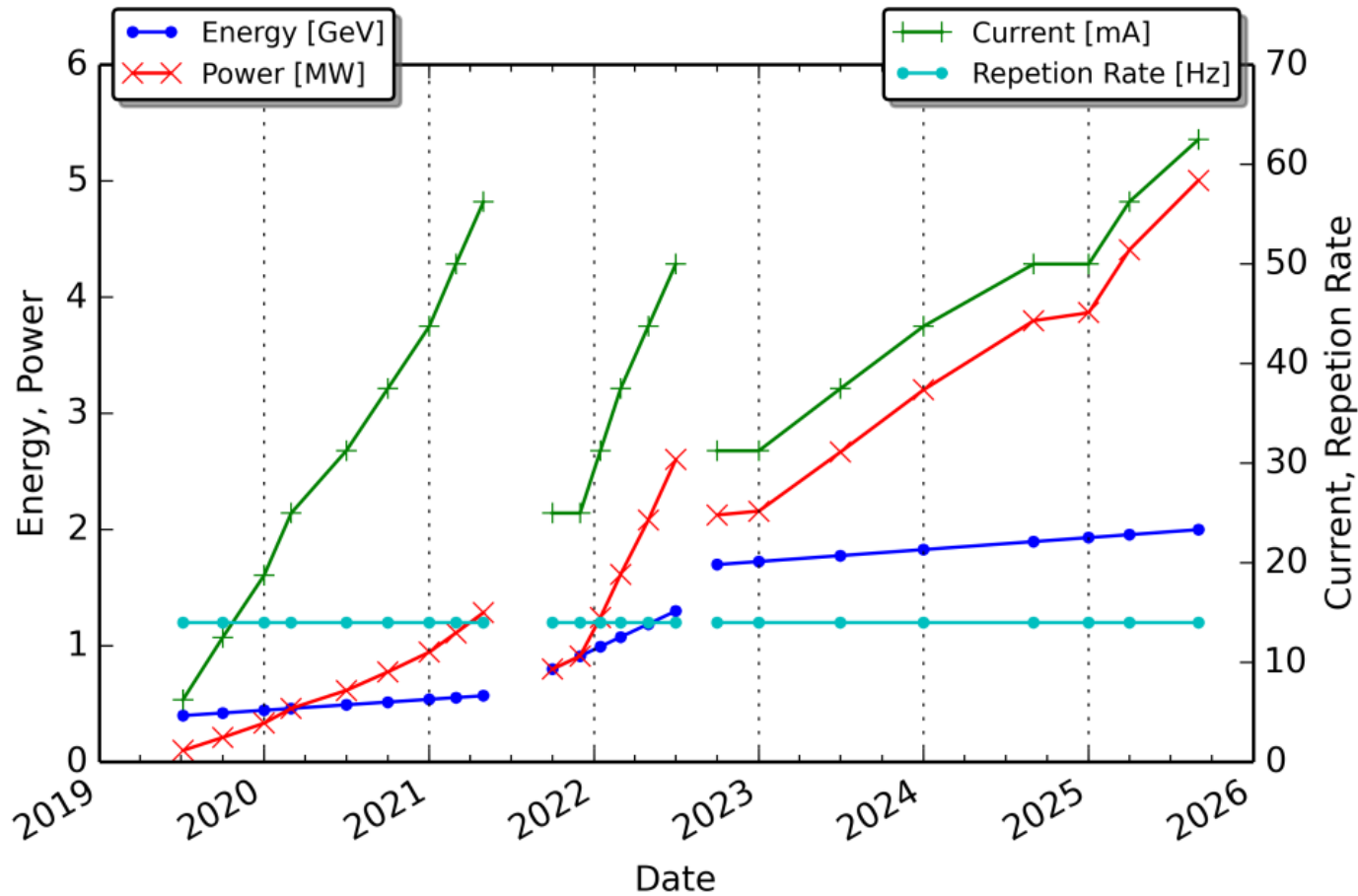

Expected Critical Equipment Lifetime and Replacement Schedule



Equipment	Lifetime (MW-h)	Basis for the lifetime limit
Target Wheel	135,000	<ul style="list-style-type: none"> 6 dpa in 316L SS target vessel
MR Plug	27,000	<ul style="list-style-type: none"> 40 dpa or 10^{23} n/cm² thermal ($E_{th} < 0.625$ eV) neutron fluence in Al
PBW	13,000	<ul style="list-style-type: none"> 2,000 appm He in Al

Year	Beam on TG (hours)	Avg. beam power (MW)	MW-h	Cum MW-h	Equipment Replacements
2020	2640	0.3	792	792	
2021	2040	0.9	1,836	2,628	
2022	2160	1.4	3,024	5,652	
2023	4560	2.2	10,032	15,684	PBW-I
2024	5040	2.7	13,608	29,292	MR-Plug-I , PBW-II
2025	5280	4.1	21,648	50,940	PBW-III, IV, MR-Plug-II

Proton beam ramp-up and damage

- Module in the FLUKA model is split in 10 regions
- The module gets thermal and fast neutron irradiation

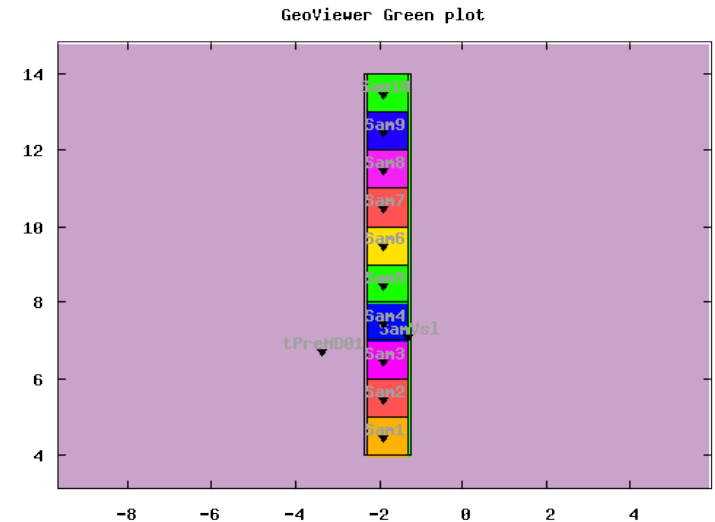
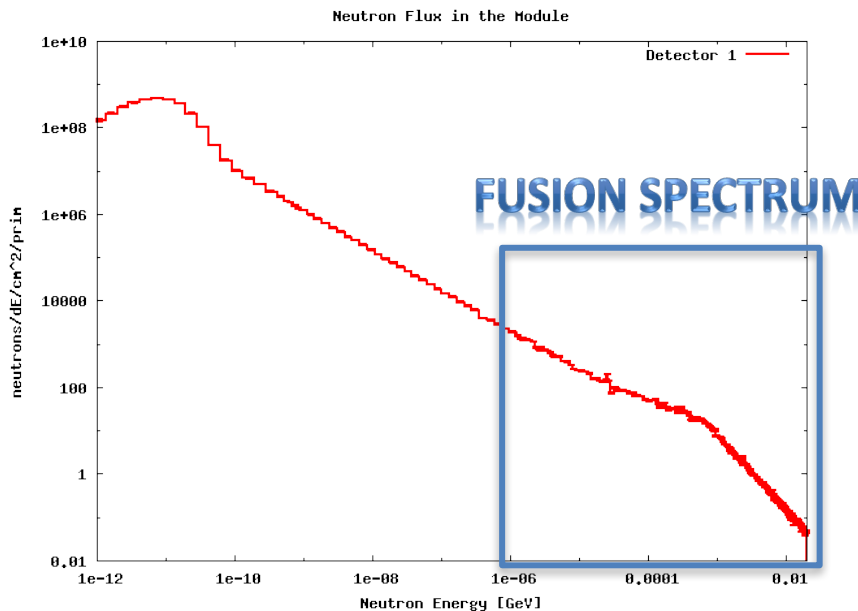

Damage for 27000 MWh

- Maximum damage: 7.6 DPA
 - Ideal Module: Maximum 13.5 DPA for 27000 MWh
- Helium to damage ratio: 15.6 He-appm/dpa

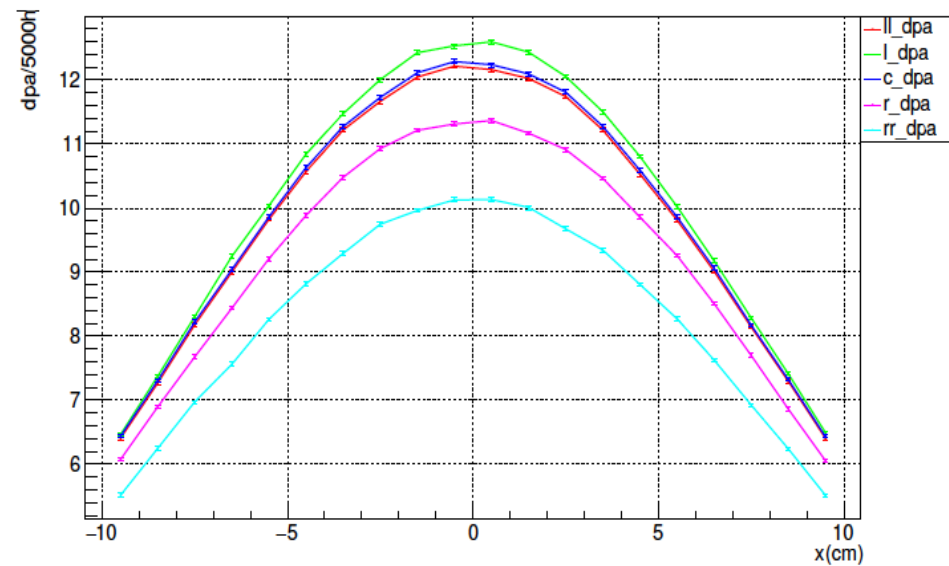
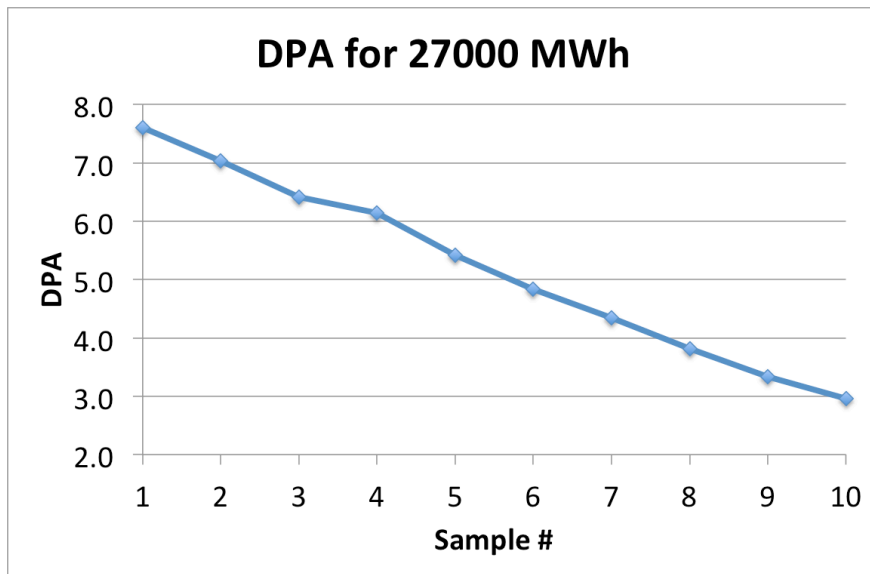

Materials for ESNIP-I

Material	Potential Applications
Al6061-T6	MR Vessel, PBW
Al5754-NET-O	MR Vessel, PBW
Al6061-T6 welded together with filler material Al4047	MR Vessel, PBW
Al6061-T6 welded to Al5754-NET-O without filler	MR Vessel, PBW
TiAl6V4	PBW, Target Vessel
Tungsten	Spallation Material, Diverter of Fusion Reactor
SS 304L	Target Vessel
SS 316L	Target Vessel
EUROFER 97	Target Vessel, Fusion Reactor Vessel
F82H	Target Vessel, Fusion Reactor Vessel

Test Specimens

Material ID	Material	Test Specimens					
		Bend Bar	Bend Fatigue	Tensile	TEM/SP	Charpy	LFA
Mat-01	Al6061-T6	Green	Light Blue	Green	Green	Light Blue	Green
Mat-02	Al5754-NET-O	Green	Light Blue	Green	Green	Light Blue	Green
Mat-03	Al6061-T6 welded together with filler material Al4047	Light Blue	Light Blue	Green	Light Blue	Light Blue	Light Blue
Mat-04	Al6061-T6 welded to Al5754-NET-O without filler	Light Blue	Light Blue	Green	Light Blue	Light Blue	Light Blue
Mat-05	TiAl6V4	Light Blue	Light Blue	Green	Green	Light Blue	Light Blue
Mat-06	Tungsten	Light Blue	Green	Green	Green	Yellow	Green
Mat-07	SS 304L	Light Blue	Light Blue	Green	Green	Light Blue	Light Blue
Mat-08	SS 316L	Light Blue	Light Blue	Green	Green	Light Blue	Light Blue
Mat-09	EUROFER 97	Light Blue	Light Blue	Green	Green	Yellow	Light Blue
Mat-10	F82H	Light Blue	Light Blue	Green	Green	Yellow	Light Blue

Bend bar specimen

- There are 2 sets of bend bars:
 - Al6061-T6
 - Al5754-NET-O
- Each material will get 5 different doses.

Bend bar specimen

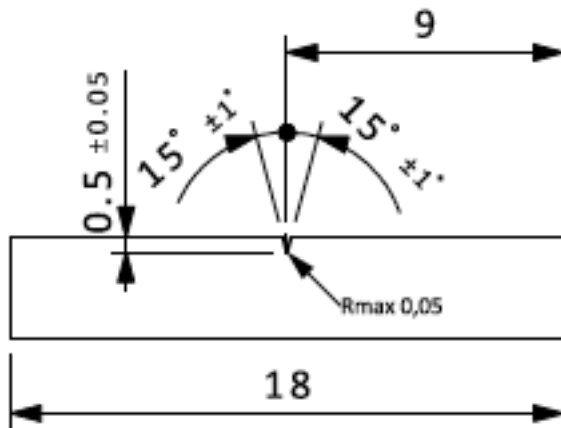

Sample dimension from STIP: Y. Dai

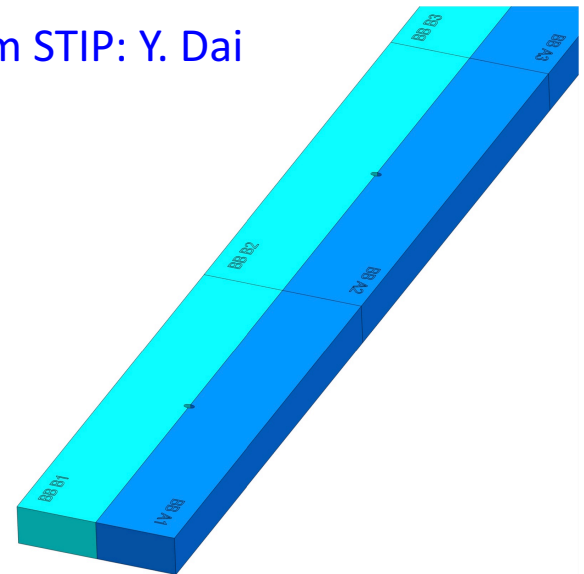
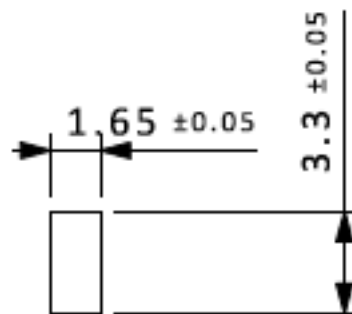

Bend fatigue bar specimen

- There is 1 set of bend fatigue bars made of tungsten
- The material will get 6 different doses.
- Per each of the 6 different radiation dose, four fatigue statics will be taken.

Bend fatigue specimen

Sample dimension from STIP: Y. Dai

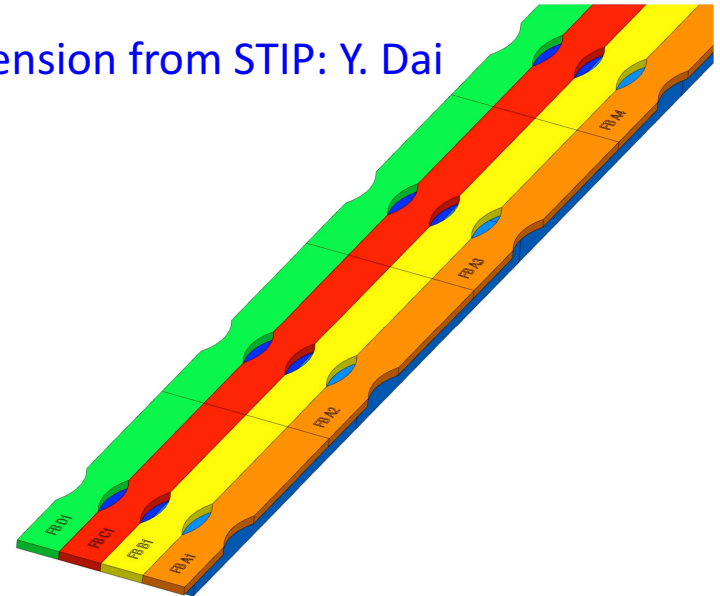
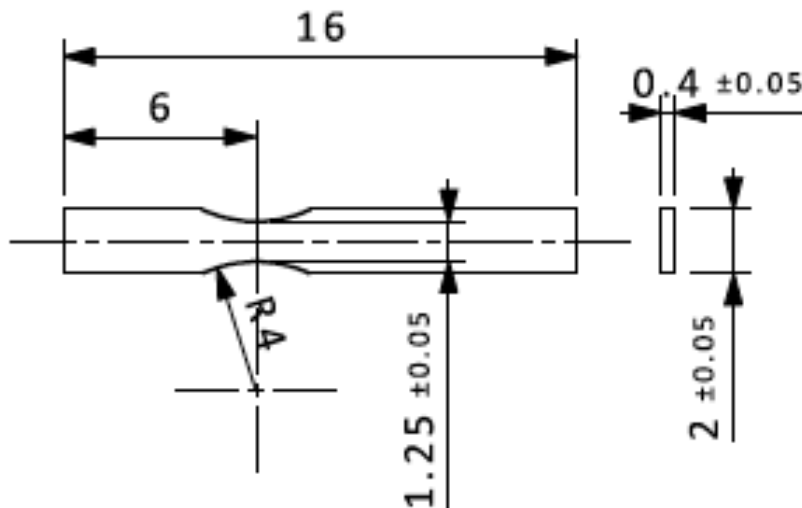

Tensile test specimen

- There are 10 sets of tensile samples:
- Each material will get 6 different doses.

Modified from the sample dimension for STIP: Y. Dai

Tensile specimen

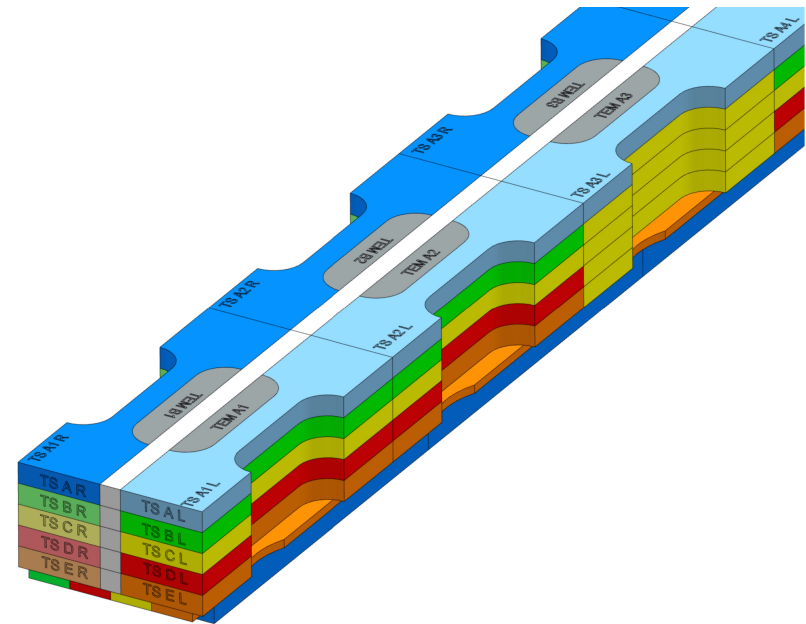
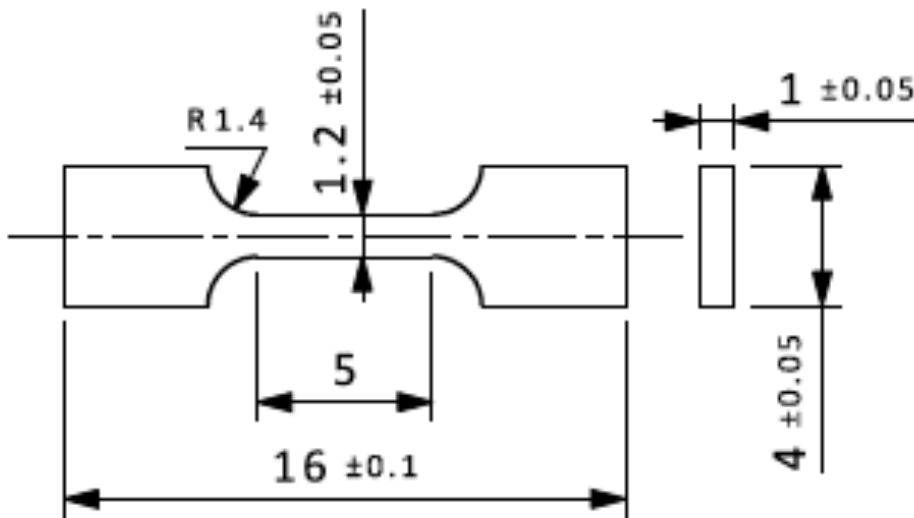

SP/TEM specimen

- There are 8 sets of SP/TEM samples:
- Each material will get 6 different doses.

Sample dimension from STIP: Y. Dai

TEM
thk = 0,25 mm

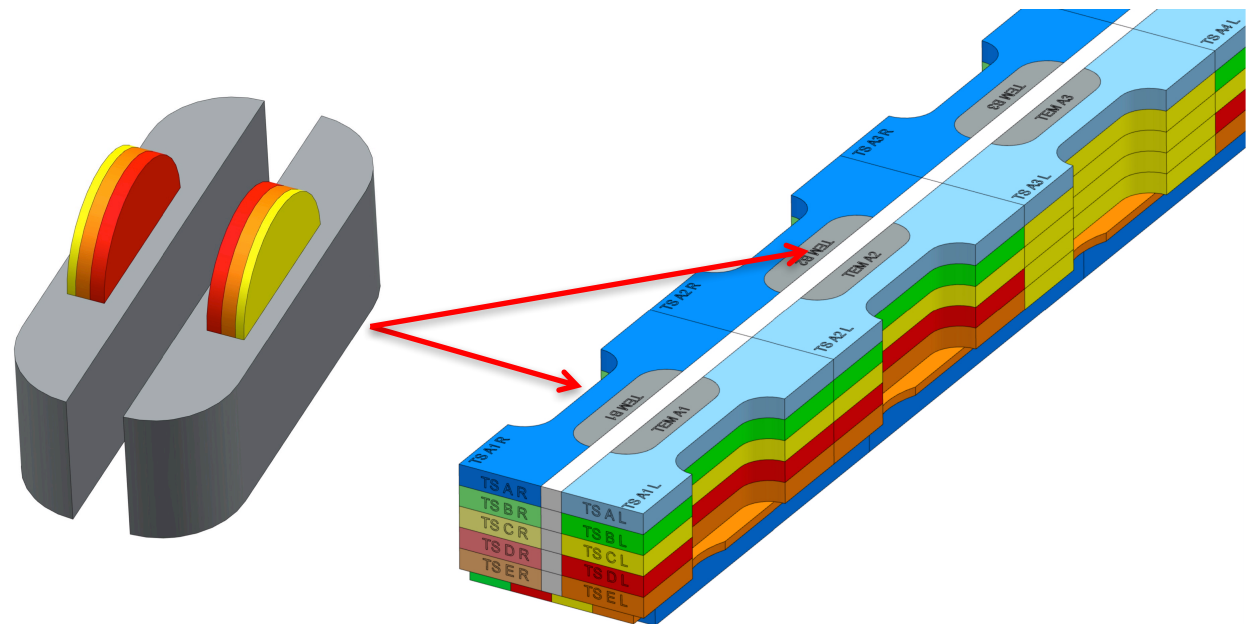

Charpy V-notch test specimen

- There are 2 sets of charpy V-notch test specimens:
 - EUROFER97 (?)
 - F82H (?)
 - Tungsten (?)
- Each material will get 3 different doses.

Sample dimension from STIP: Y. Dai

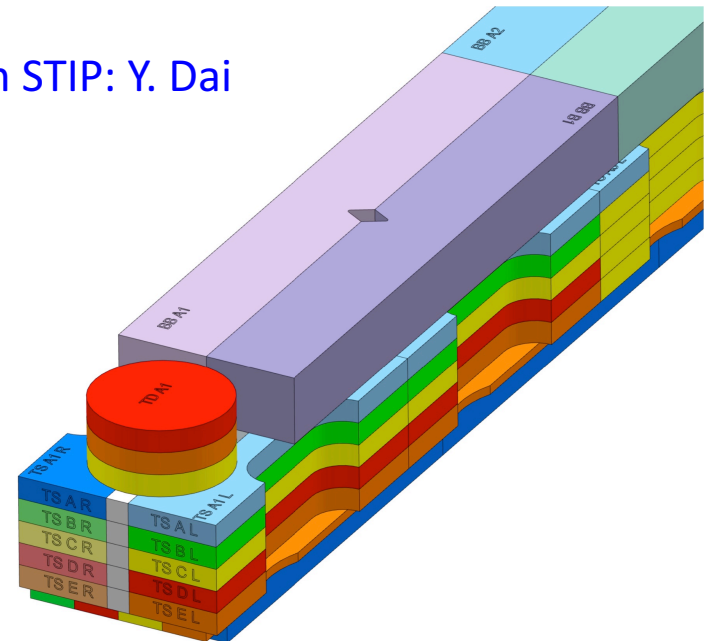
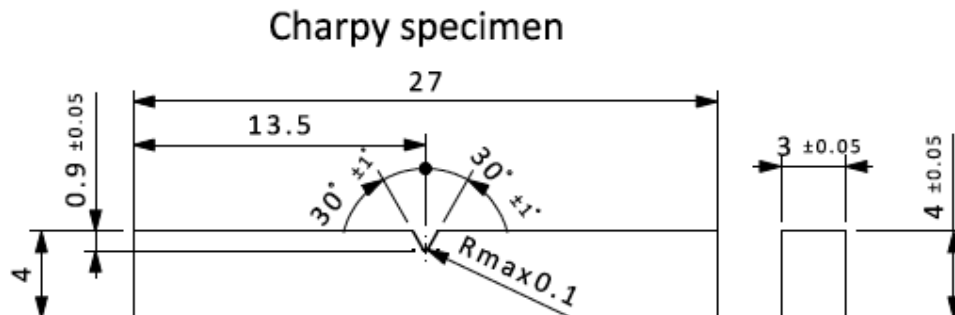

LFA (Laser Flash Analysis) specimen

- There are 3 sets of LFA specimens:
 - Al6061-T6
 - Al5754-NET-O
 - Tungsten
- Each material will get 2 different doses.

Thermal conductivity disc
thk = 1mm

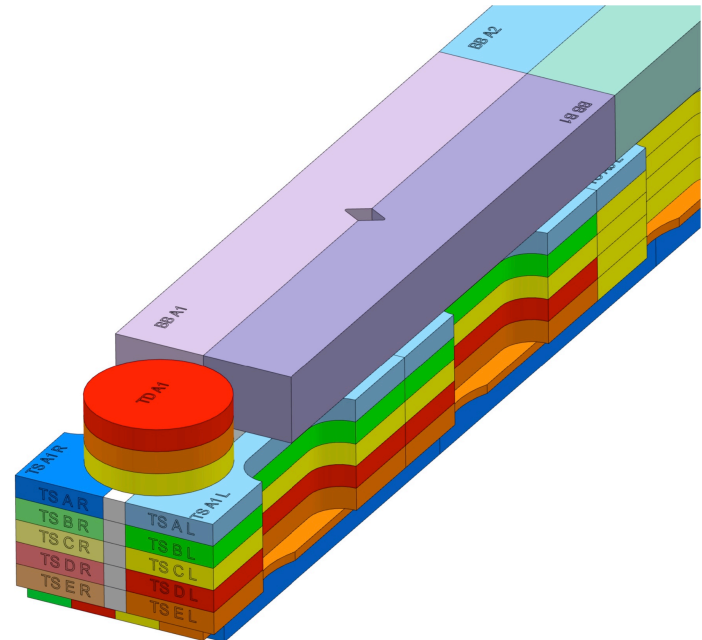
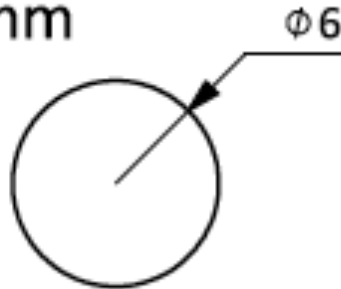

Temperature and fluence monitoring

- Temperature monitoring
 - CVD SiC bars placed between the tensile specimens
- Fluence monitoring
 - 0.025 mm thin foils with diameter of 3 mm, made of Al (99.999%), Co (99.9%), Cu (99.999%), Fe (99.99%), Ni (99.999%) and Nb (99.9%)

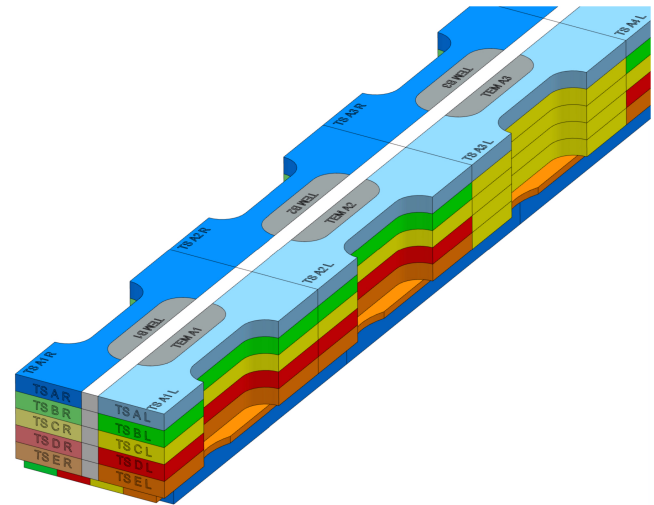
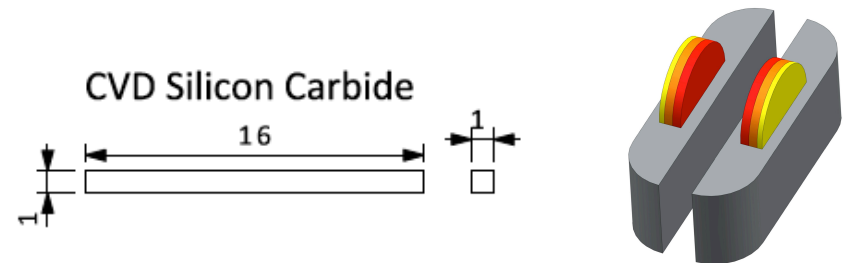

Samples in final assembly

- Double vessel structure:
 - Mitigating the risk of water channel clogging

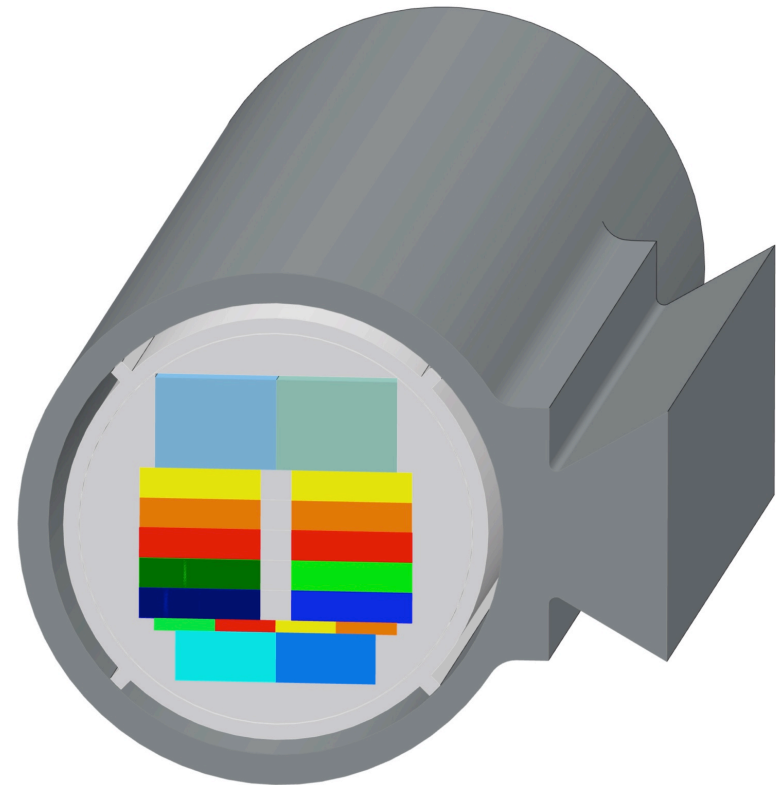
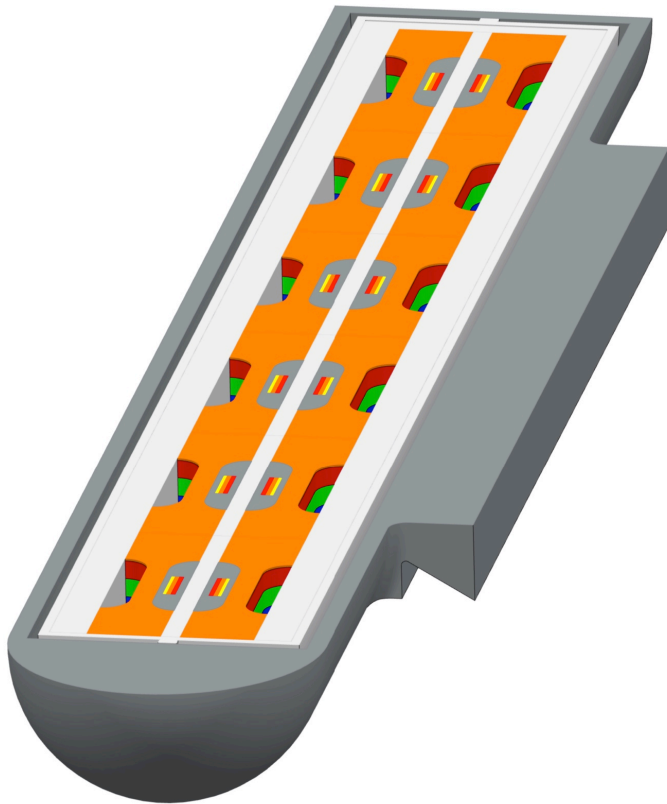

Temperature and Stress Analyses

- The introduction of an Irradiation Module does not jeopardize the integrity of the thermal moderator.
- The maximum temperature in the sample can be kept below 130 °C, by adjusting the gap design.

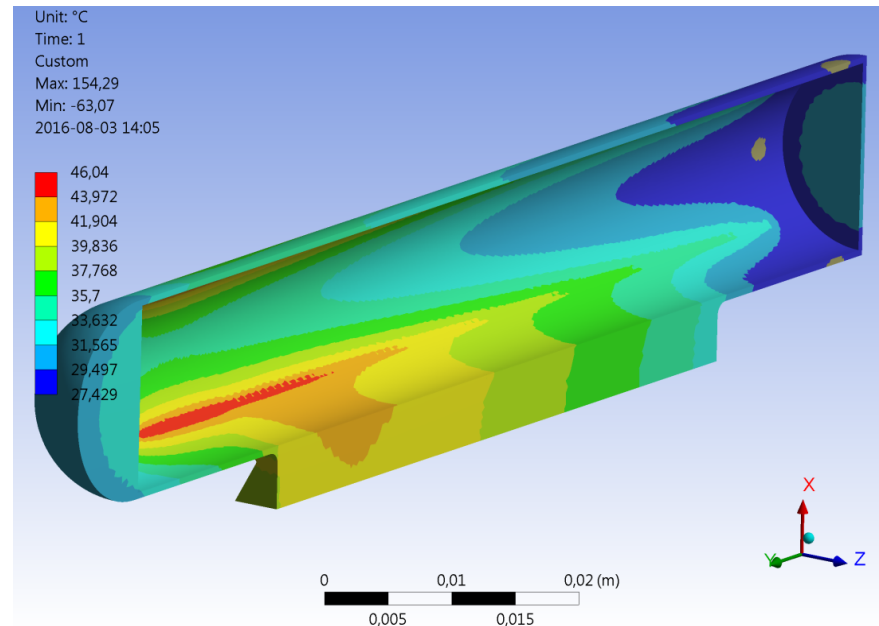
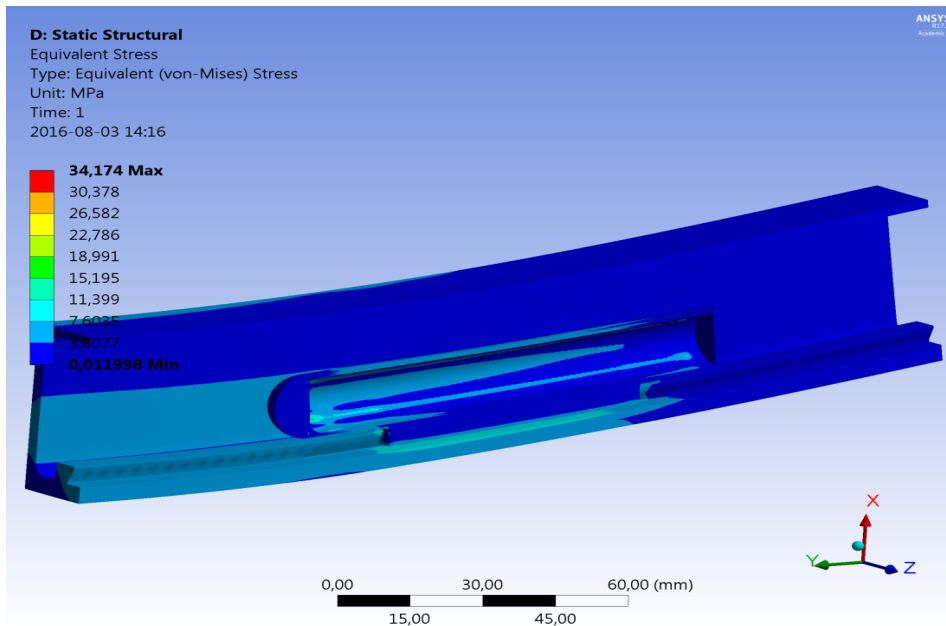

Post Irradiation Examination (PIE)

- Irradiation module extraction and cooling
 - Remote handling in Active Cells
 - Activation measurement
 - Identification of the required cooling time to enable cross-border transport in a Type-A equivalent container
- Conduction of PIE
 - Identification of a partner lab
 - Contract with a partner lab
 - Transport of the module to the partner lab
 - Extraction of the samples in a hot cell
 - Perform planned PIEs
 - Estimated cost: 300 k€ per PIE contract (Benchmarking SNS)

PIECE (PIE Cells at ESS: Vision)

- Allocated Function: Scientifically investigate the activated PIE specimen

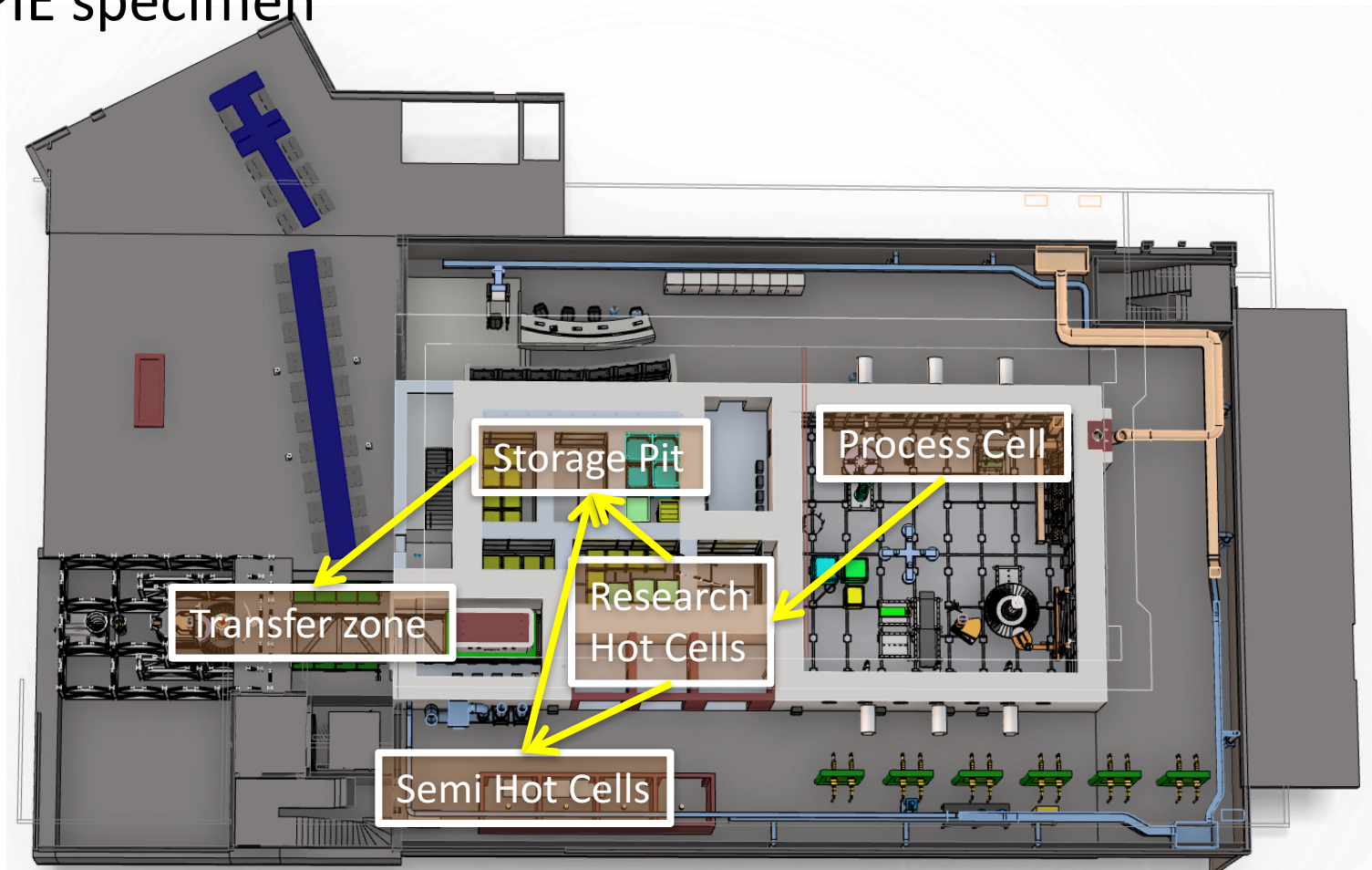

Interface: Process Cell and PIECE

- Two way transfer port:
 - It shall not break the shielding between the process cell and the sample preparation cell, while the sample material is being transported between the two cells.

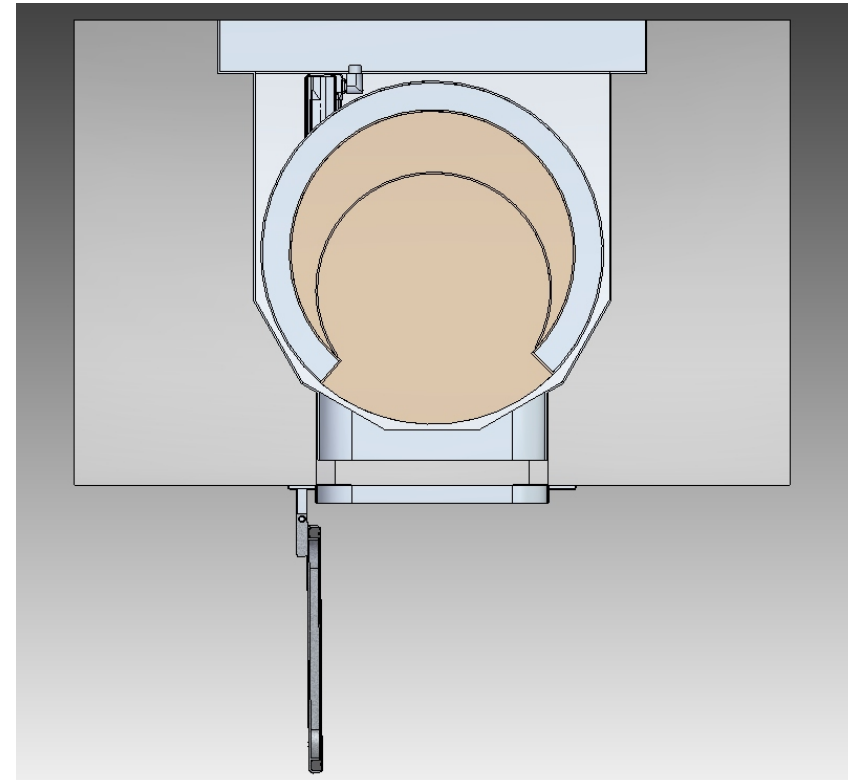
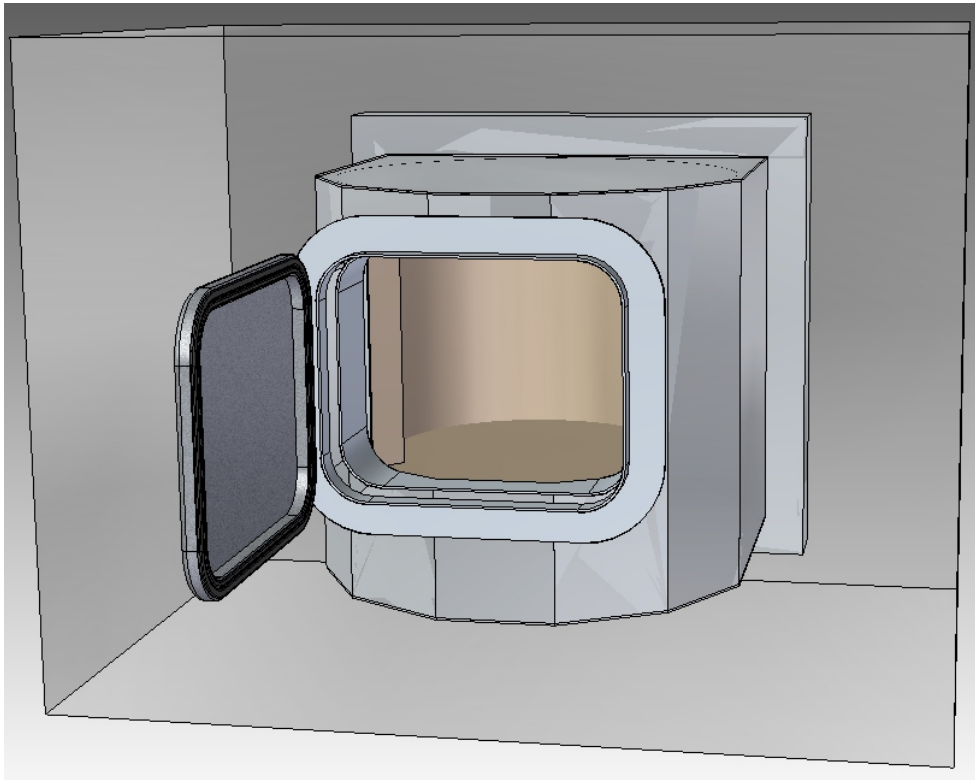

ESNIP-I features summary

- PIE data could be used to extend the operation lifetime of the MR system
- The ferrous metal samples will get the damage dose that is equivalent to the maximum lifetime dpa of the target vessel
- The helium to dpa ratio of 15.6 He-appm/dpa in ferrous metals simulates the fusion neutron damage
- The aluminium samples will get the damage dose of the operating RT MR vessel
- The tungsten will get more than the lifetime damage 2 dpa of the ITER diverter

Project Status: Irradiation Module

- Project under the leadership of an in-kind partner:
 - Consiglio Nazionale delle Ricerche (CNR: National Research Council), Italy
- Conducted “Critical Design Review”
 - Upon approval, the procurement and manufacturing process will begin
- The schedule is in line with the manufacturing of the water moderator vessel
 - The capsule will be manufactured and installed by the MR-system engineering team of FZJ

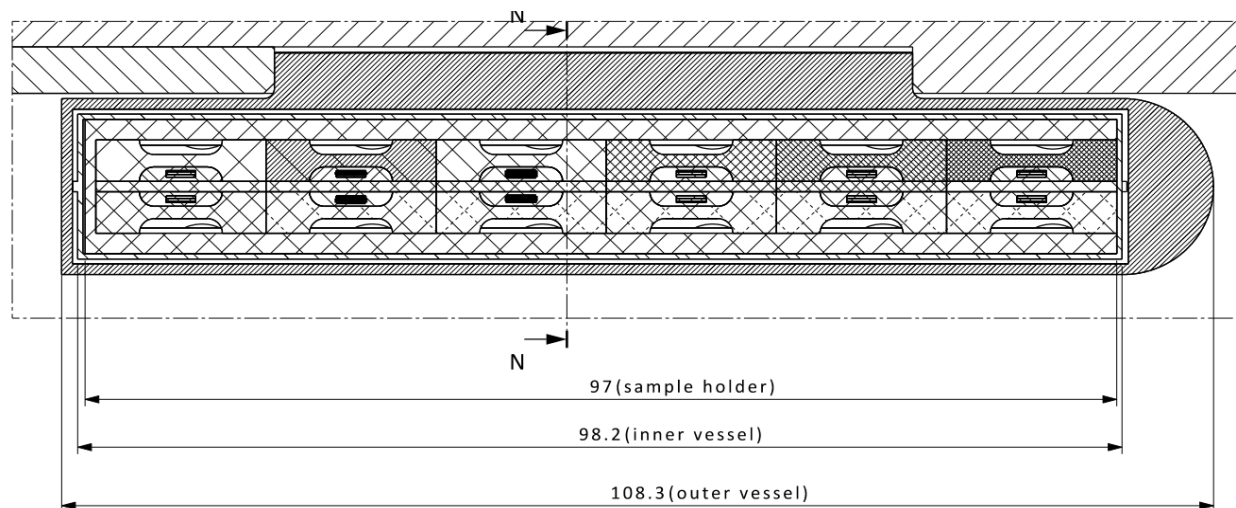

ESNIP-II for fusion materials program

- High damage rate of 13.5 dpa/year with < 20 He-appm/dpa
 - DEMO reactor: 12 dpa/year in the first wall steel.
- The ESNIP-II will be complementary to the proposed IFMIF-DONES project.
 - 40 MeV, 125 mA Deuteron Beam
 - Damage rate > 13.5 dpa/year up to the total accumulated damage of 50 dpa
 - Irradiation volume $> 300 \text{ cm}^3 = 10$ ESNIP-II irradiation modules

Thank you!

