

8

7

6

5

4

3

2

1

NEXT USED ASSEMBLY
S03000000-M8U-8800-A10000

NO REPRESENTATION OR WARRANTY, EXPRESSED OR IMPLIED, IS MADE AS TO THE ACCURACY, COMPLETENESS OR USEFULNESS OF THE INFORMATION OR STATEMENTS CONTAINED IN THESE DRAWINGS, OR THAT THE DISCLOSURE OF ANY INFORMATION, APPARATUS, METHOD OR PROCESS DISCLOSED IN THESE DRAWINGS MAY NOT INFRINGE PRIVATE RIGHTS OF OTHERS. NO LIABILITY IS ASSUMED WITH RESPECT TO THE USE OF, OR FOR DAMAGES RESULTING FROM THE USE OF, ANY INFORMATION, APPARATUS, METHOD OR PROCESS DISCLOSED IN THESE DRAWINGS. DRAWINGS MADE AVAILABLE FOR INFORMATION TO BIDDER ARE NOT TO BE USED FOR OTHER PURPOSES AND ARE TO BE RETURNED UPON REQUEST OF THE FORWARDING CONTRACTOR.
THIS DRAWING IS THE PROPERTY OF OAK RIDGE NATIONAL LABORATORY.

APPROVAL BLOCK

REV	DESCRIPTION OF CHANGE	DES	CHK	ENG	API	AP2	AP3	DATE
A	DRAFT FOR PRELIMINARY DESIGN REVIEW							

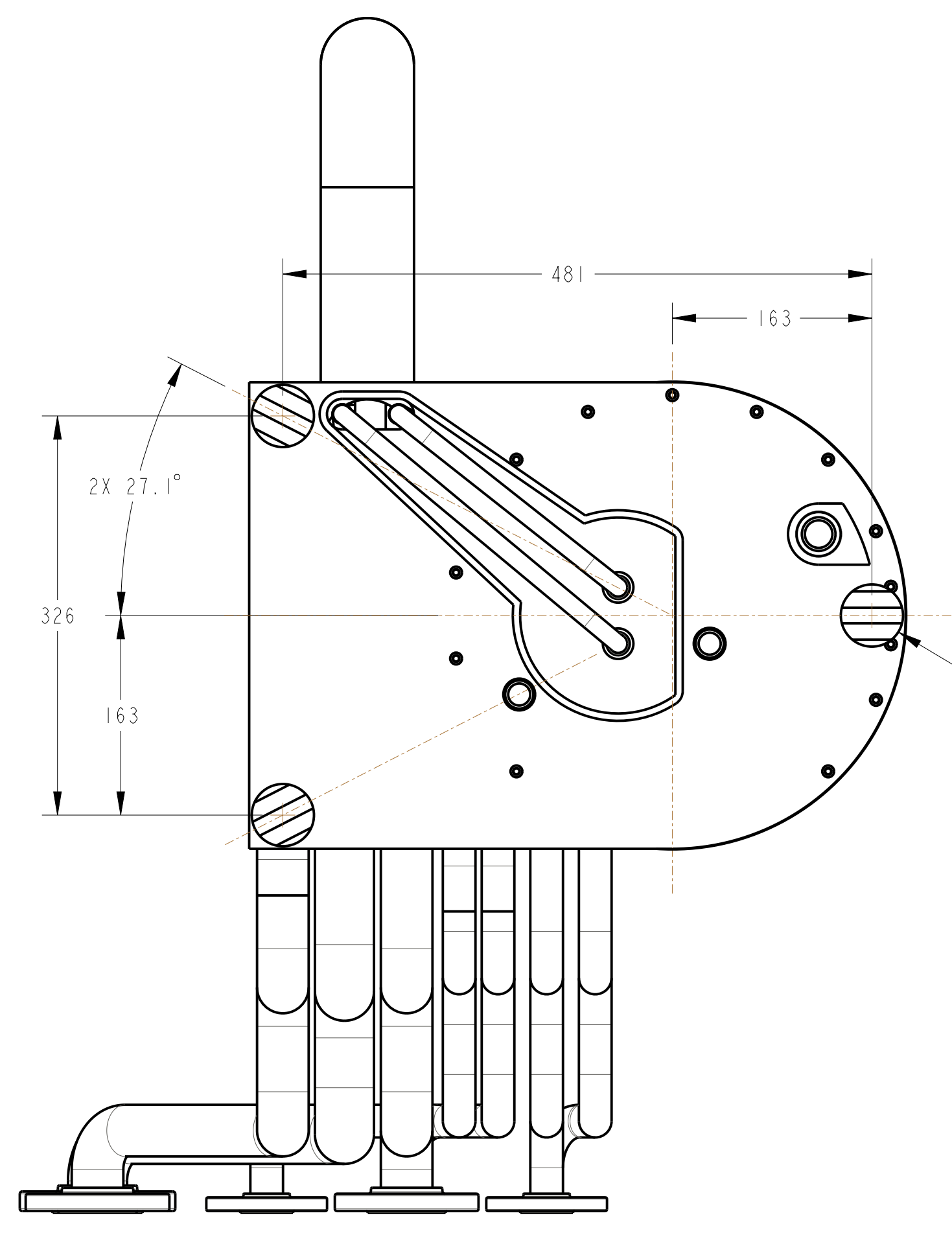
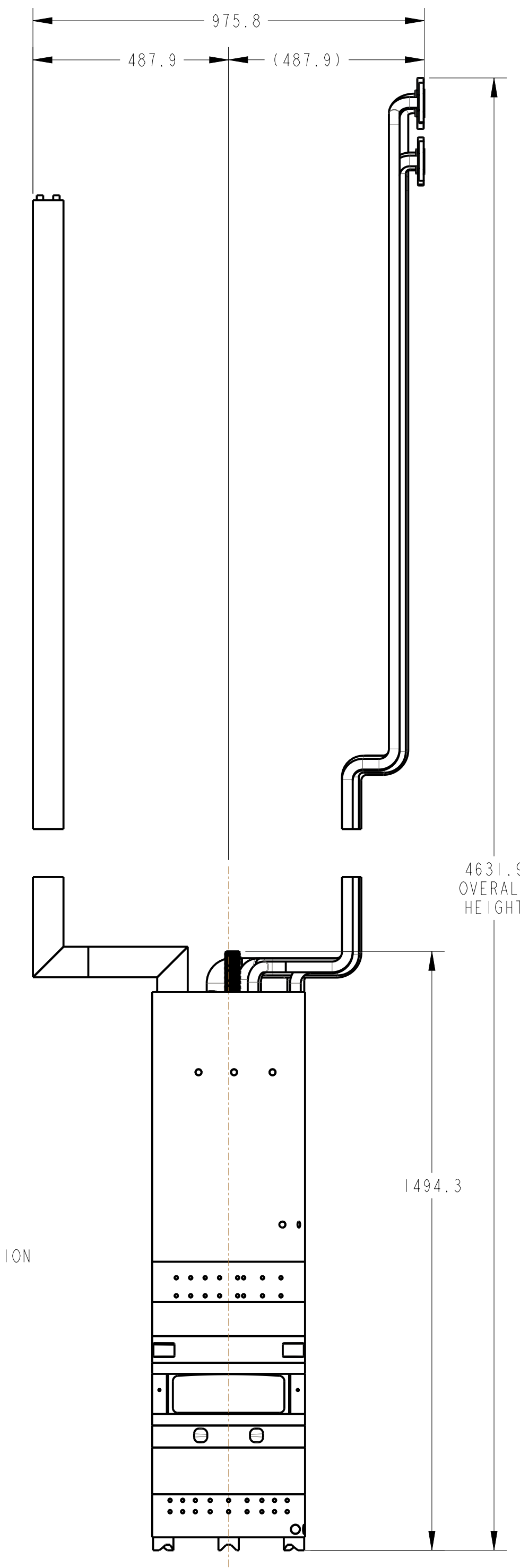
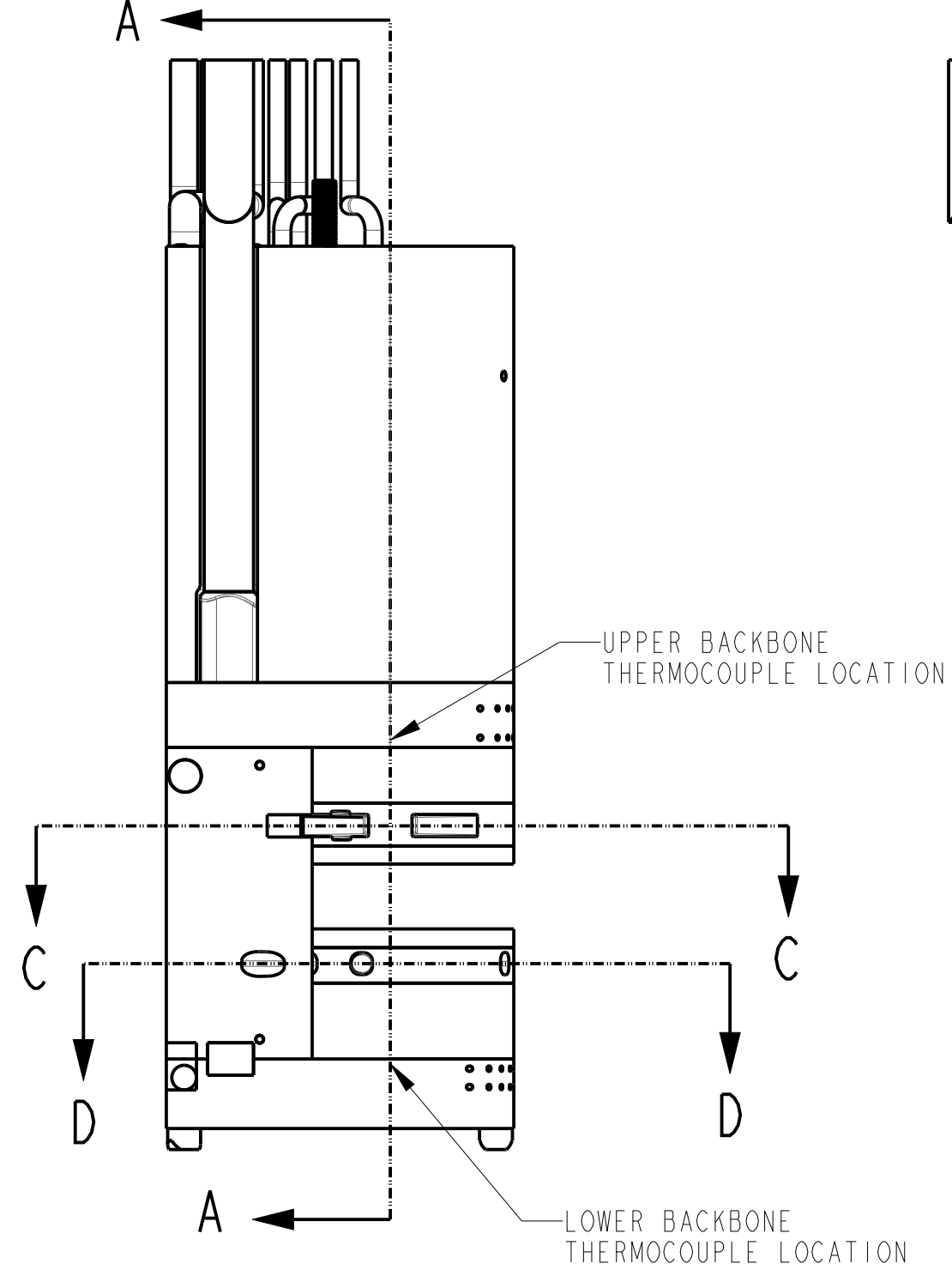
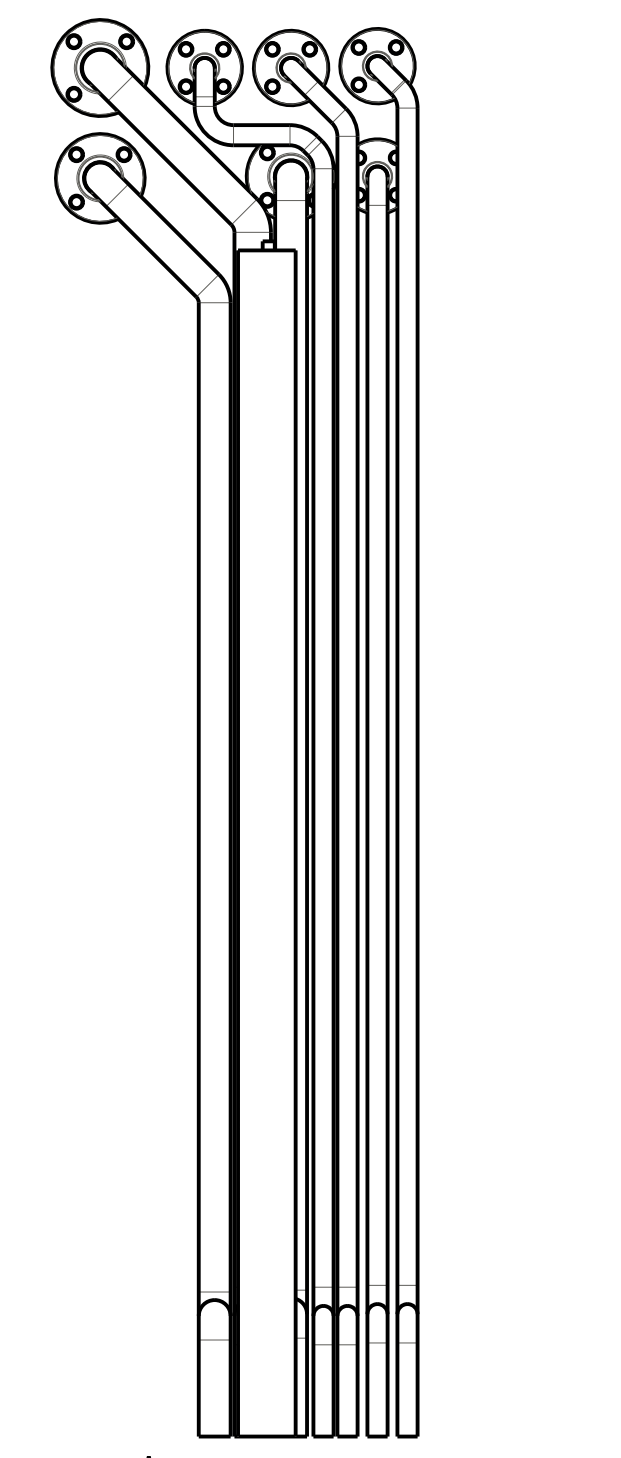
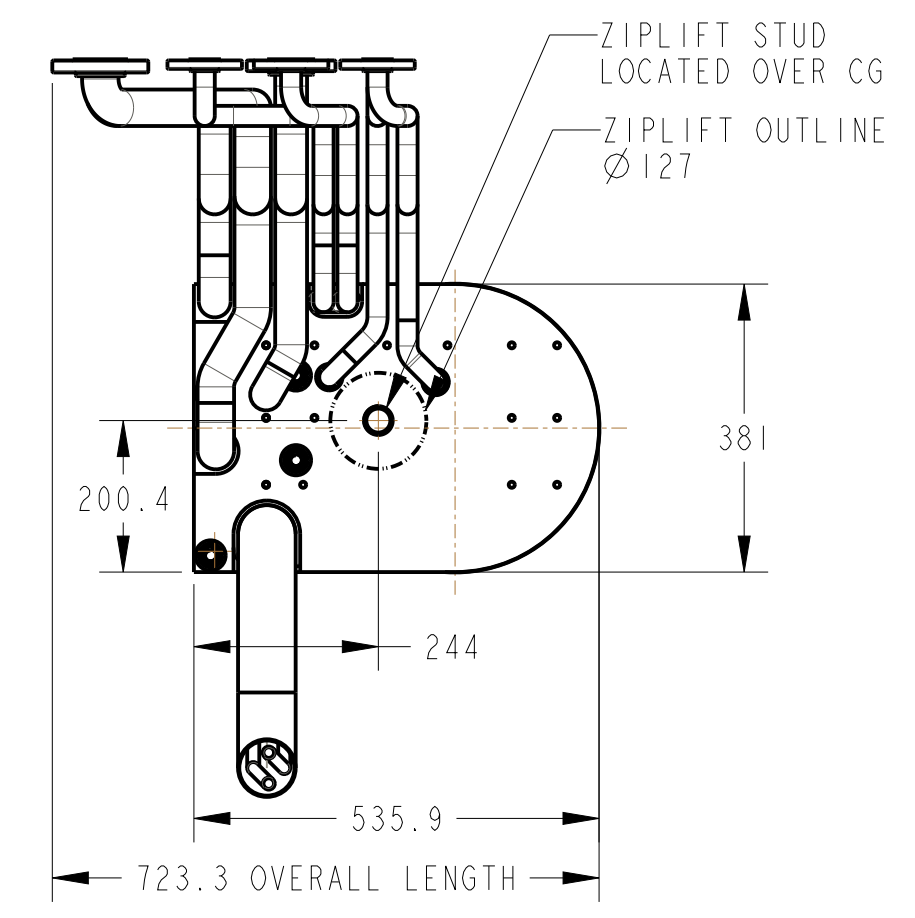

BOTTOM VIEW-VEE BLOCK DETAILS
SCALE 1:4

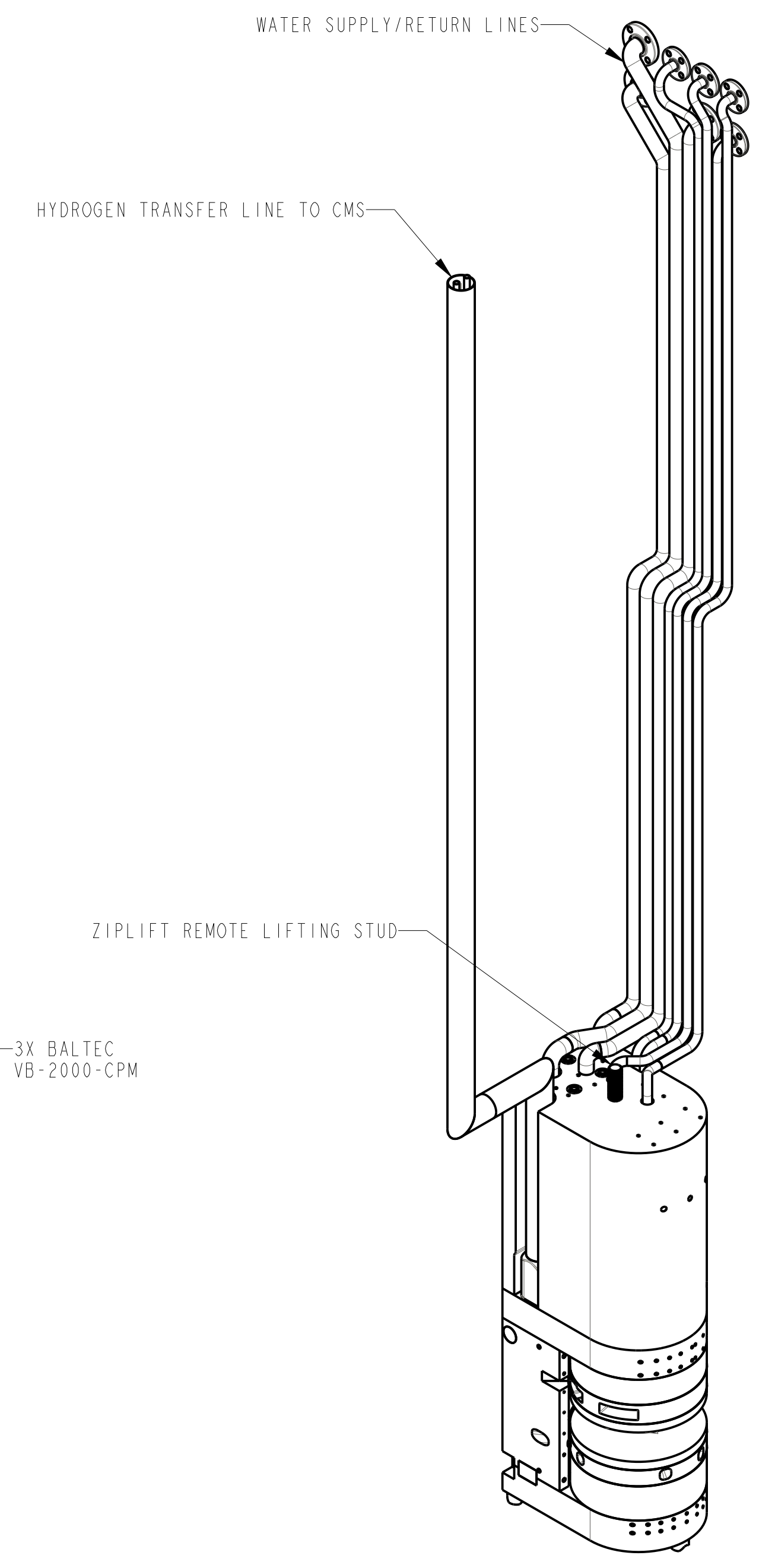

SCALE 2:25

UNITS: MILLIMETERS	
DEFAULT TOLERANCES	
0-6 ±0.1	
6-120 ±0.2	
ANGULAR ±5°	
BREAK ALL SHARP EDGES EXCEPT AS NOTED: 15 MAX	
SURFACE ROUGHNESS: 3.2 Ra UNO.	
DRAFTING STD: ASME Y14.100 D & T: ASME Y14.5 WELD SYMBOLS: AWS A2.4	
THIRD ANGLE PROJECTION	



SECOND TARGET STATION
TARGET SYSTEMS
MODERATOR REFLECTOR ASSEMBLY

DRAWING NUMBER	REV		
S03040000-M8U-8800-A10000	A		
SIZE	SCALE	WEIGHT	SHEET
D	1:10	1489 kg	1 of 5

8

7

6

5

4

3

2

1

8

7

6

5

4

3

2

1

D

D

C

C

B

B

A

A

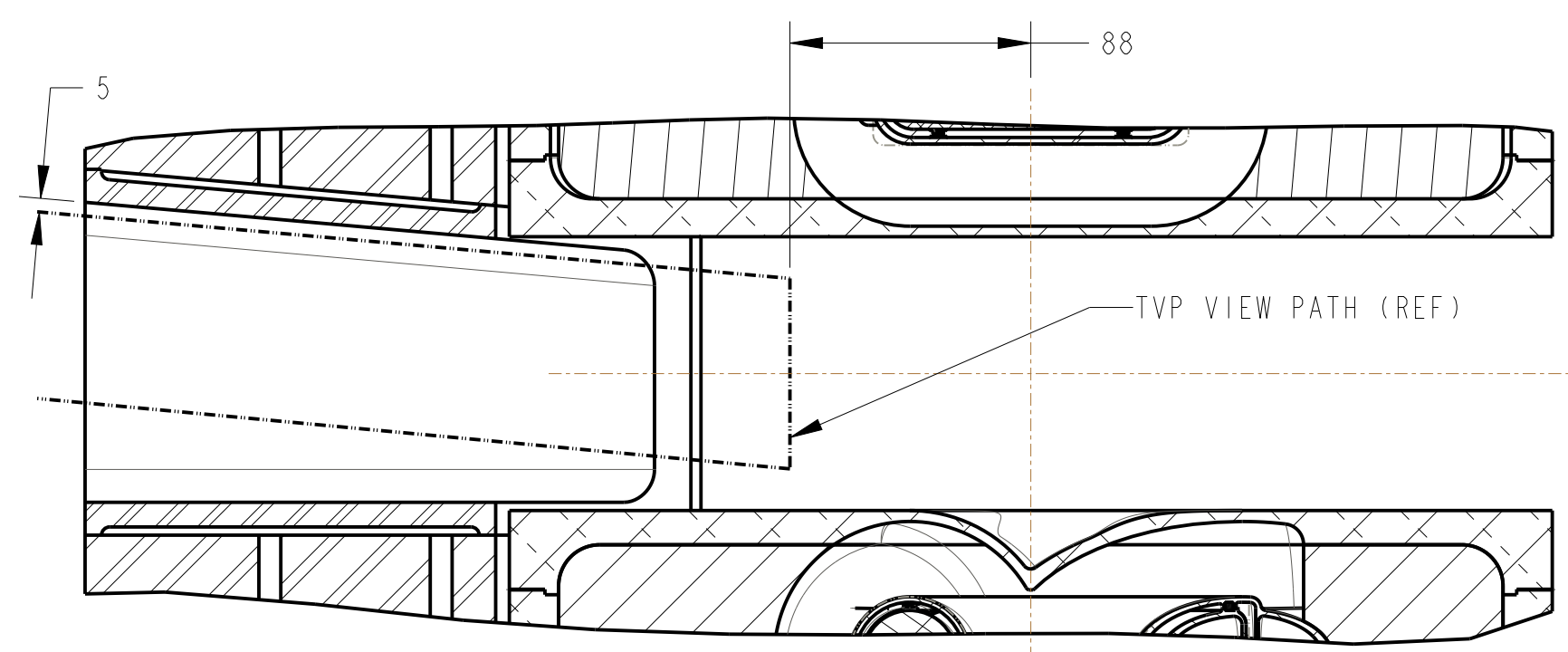

TVP DETAIL
 DETAIL C
 SCALE 2:5

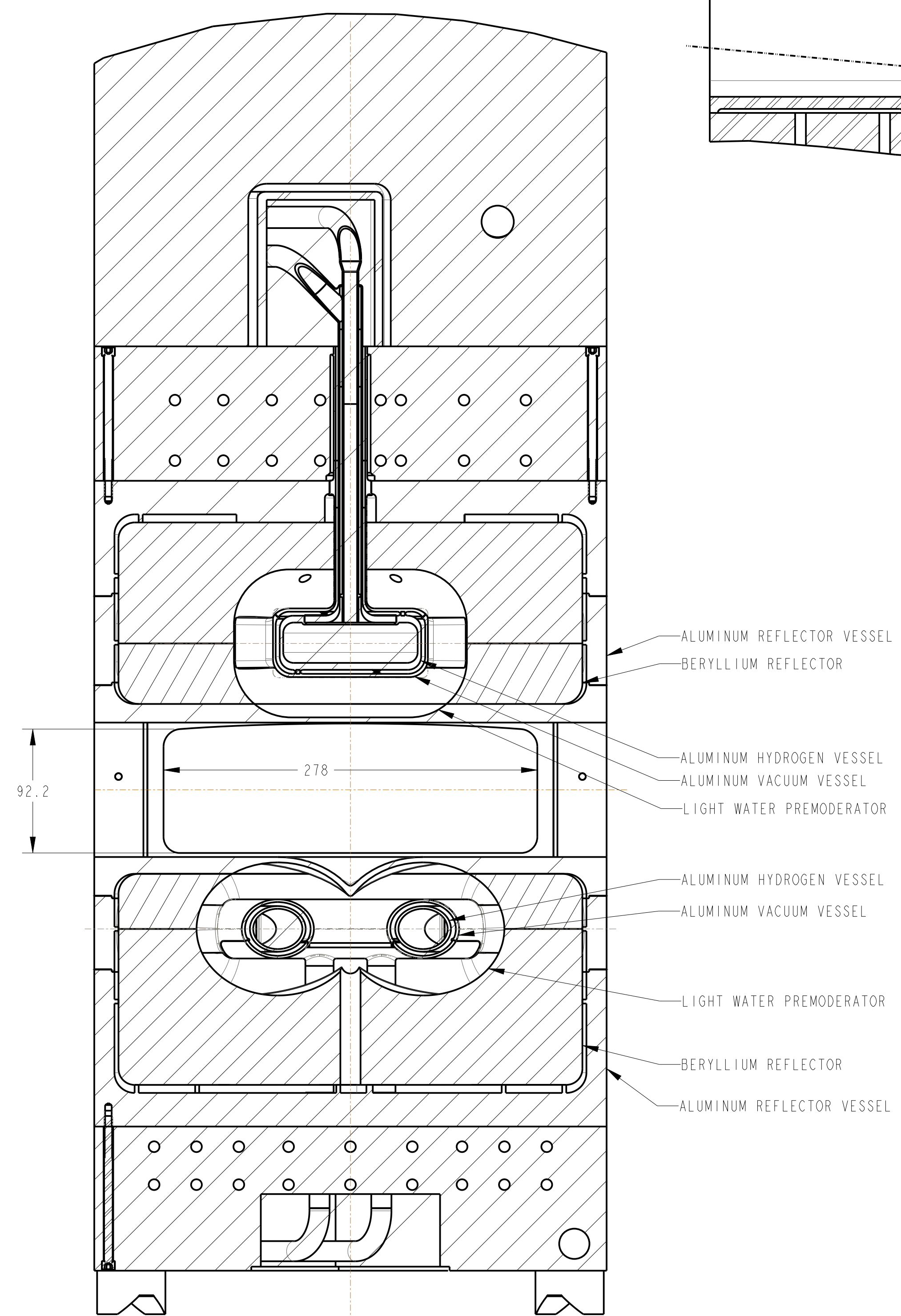

SECTION THROUGH MODERATORS
 SECTION A-A
 SCALE 2:5
 SEE SHEET 1

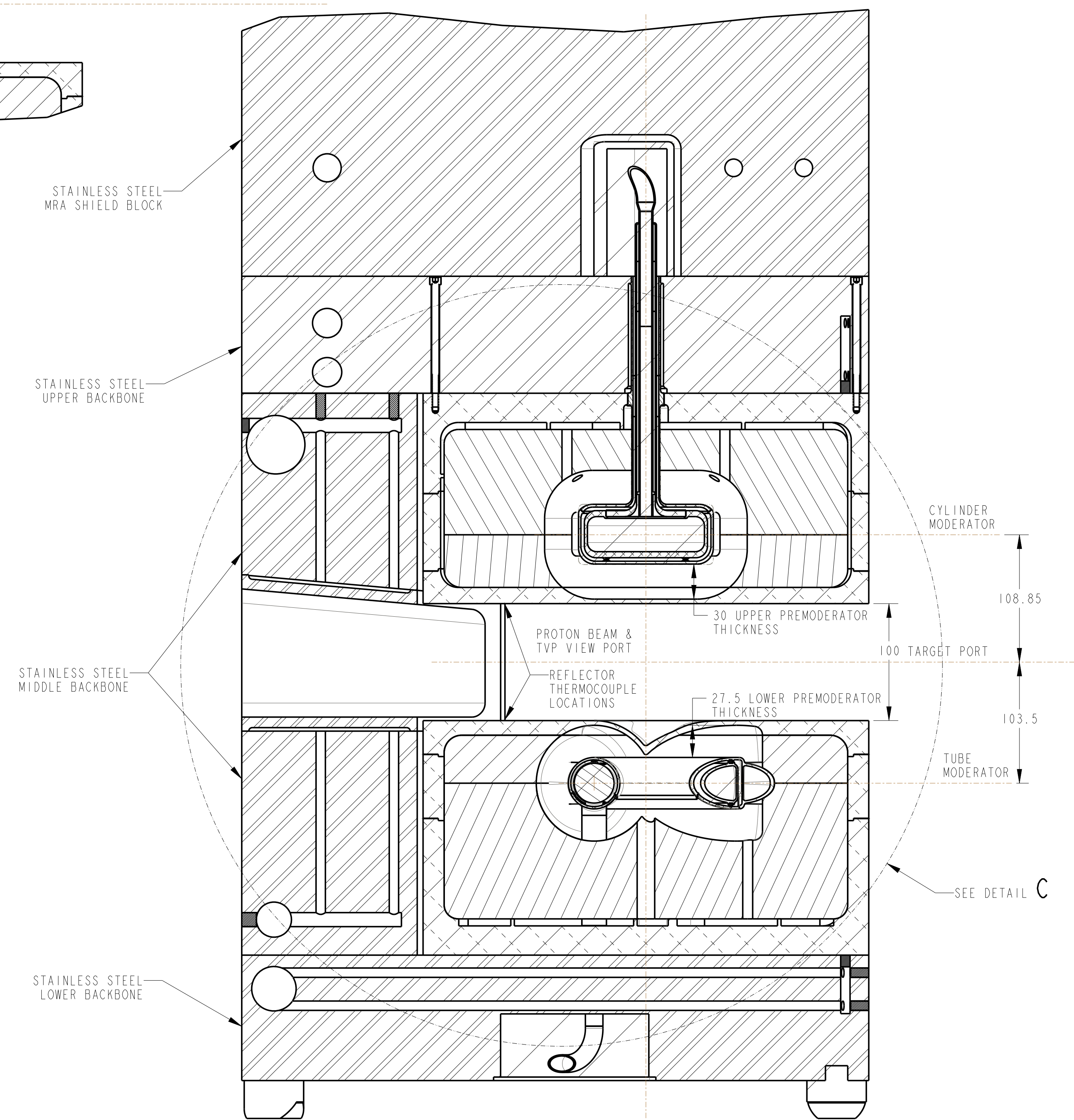

SECTION THROUGH MODERATORS
 SECTION B-B
 SCALE 2:5
 SEE SHEET 1

SIZE	SCALE	SHEET	DRAWING NUMBER	REV
D	1:5	2 OF 5	S03040000-M8U-8800-A10000	A

8

92196A307.SS-075X4.25

13 22

6

5

4

3

2

1

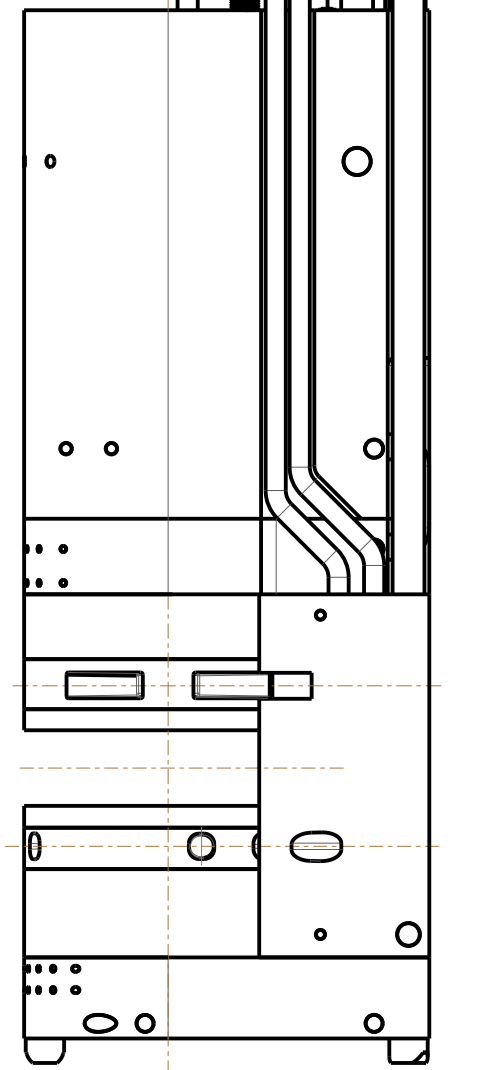
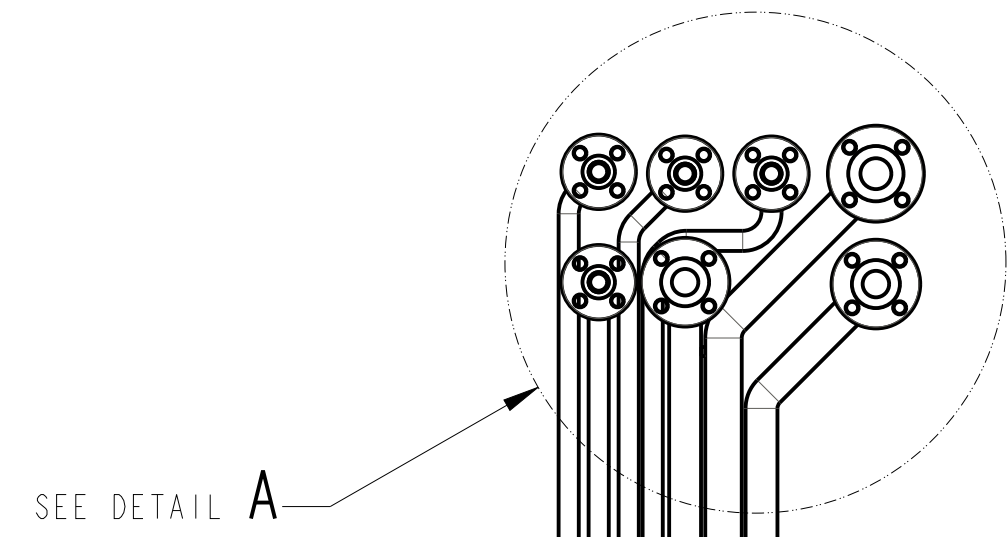

PIPING VIEW
SCALE 1:10

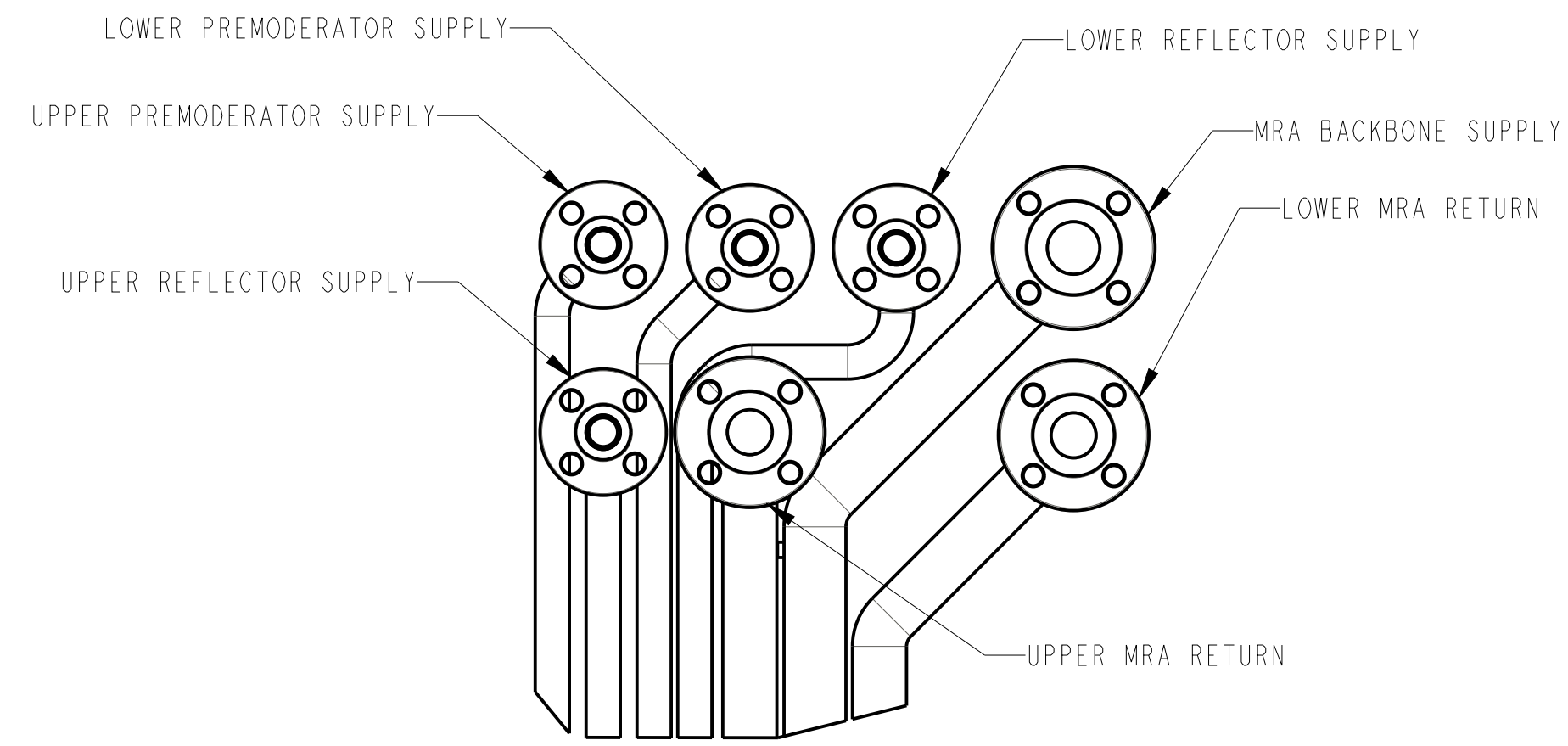

DETAIL A
SCALE 1:5

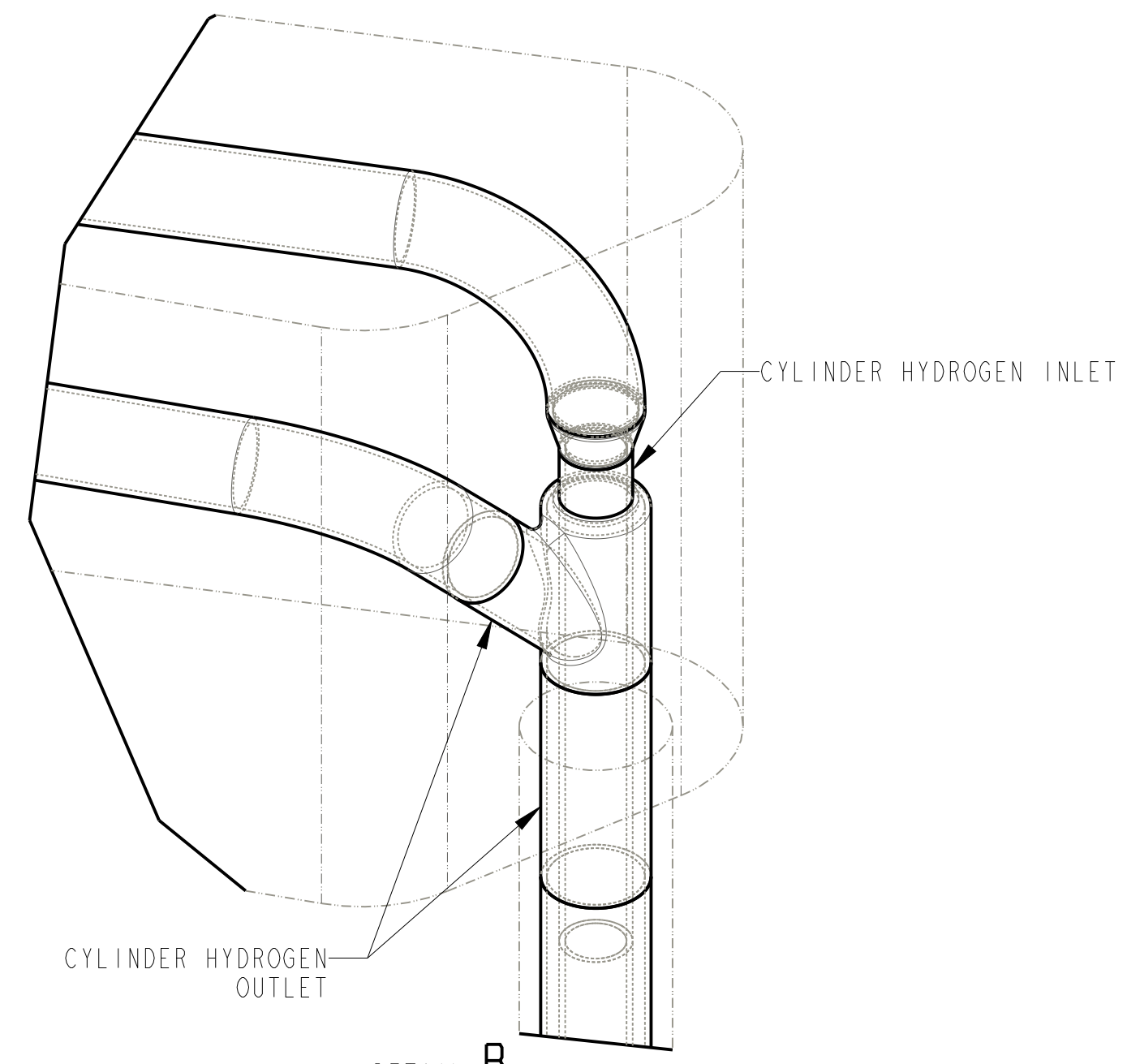
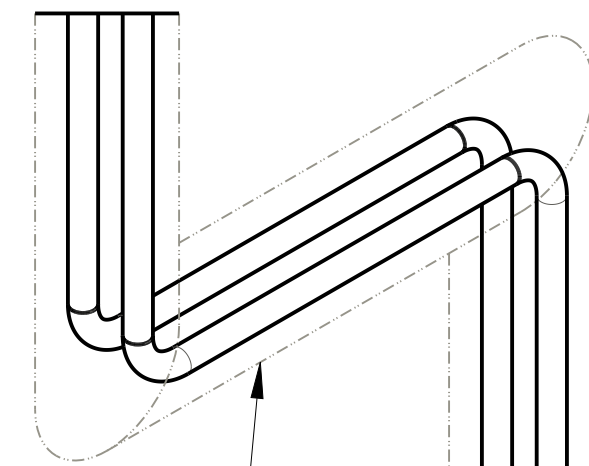
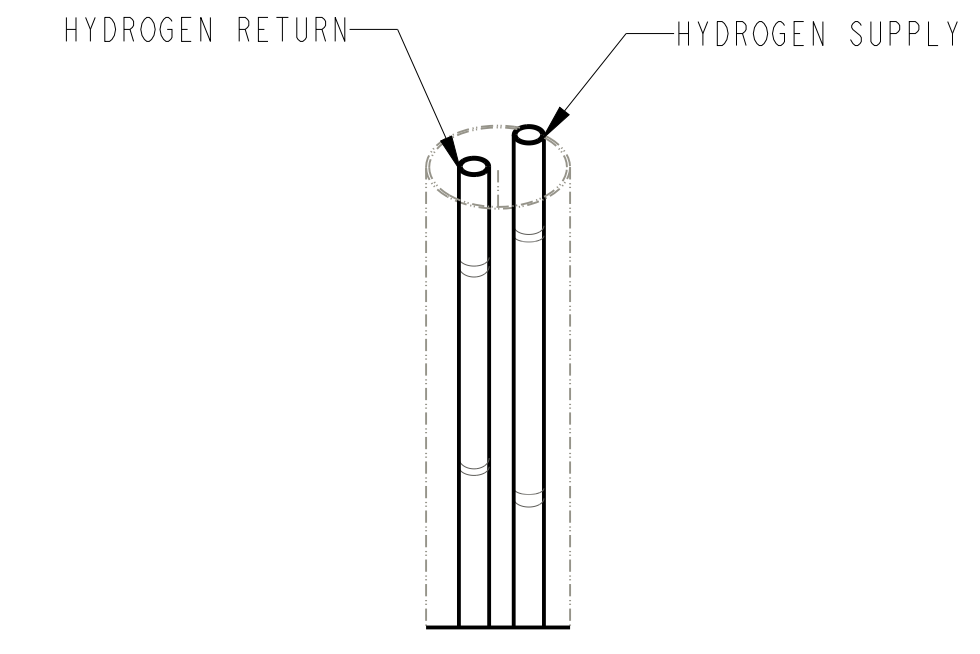

DETAIL B
SCALE 1:1

ENCLOSED WITHIN
CONTINUOUS VACUUM BOUNDARY

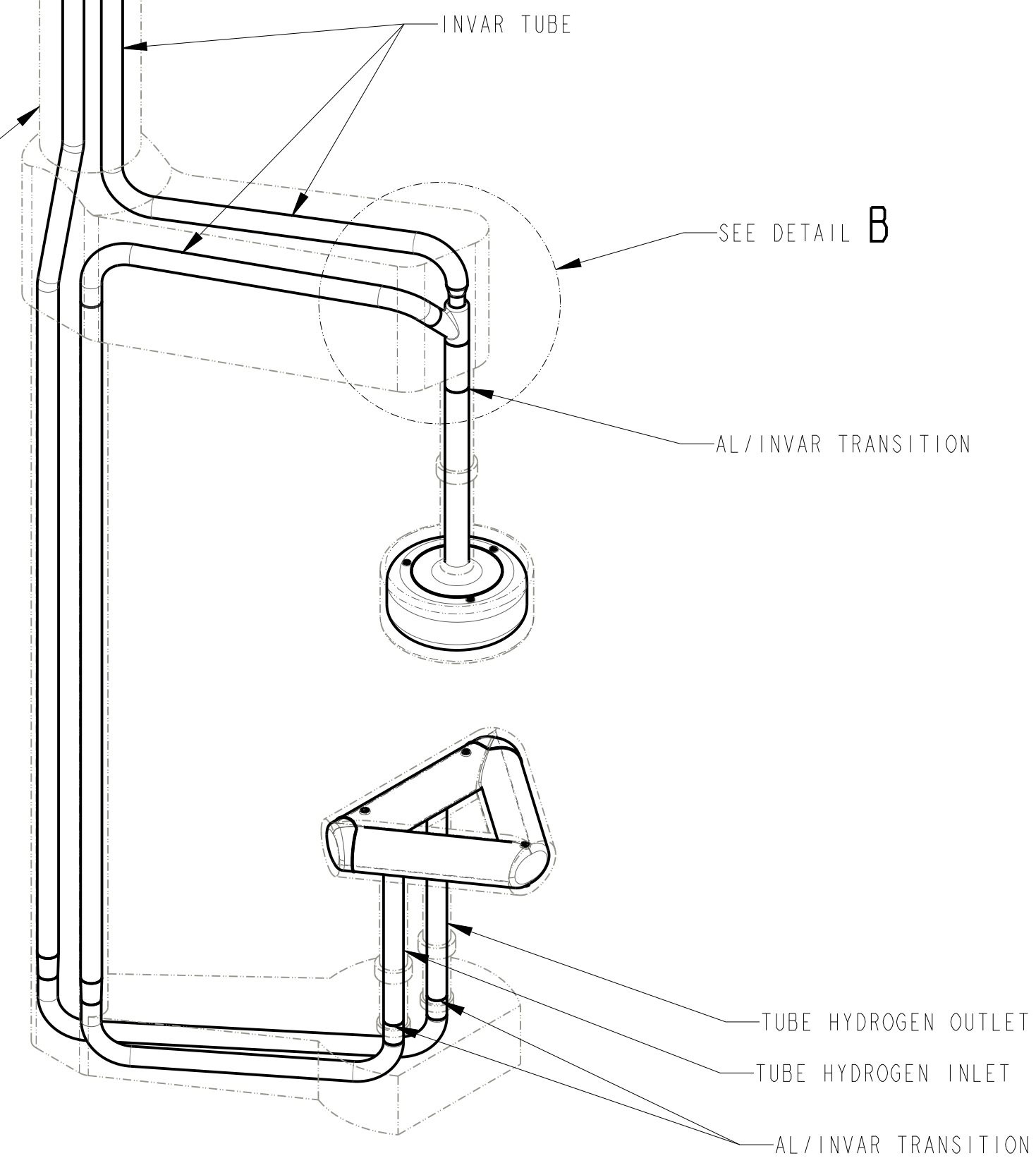

SCALE 1:4
HYDROGEN BOUNDARY

SIZE	SCALE	SHEET	DRAWING NUMBER	REV
D	1:5	3 OF 5	S03040000-M8U-8800-A10000	A

8 7 6 5 4 3 2 1

D
C
B
A

D
C
B
A

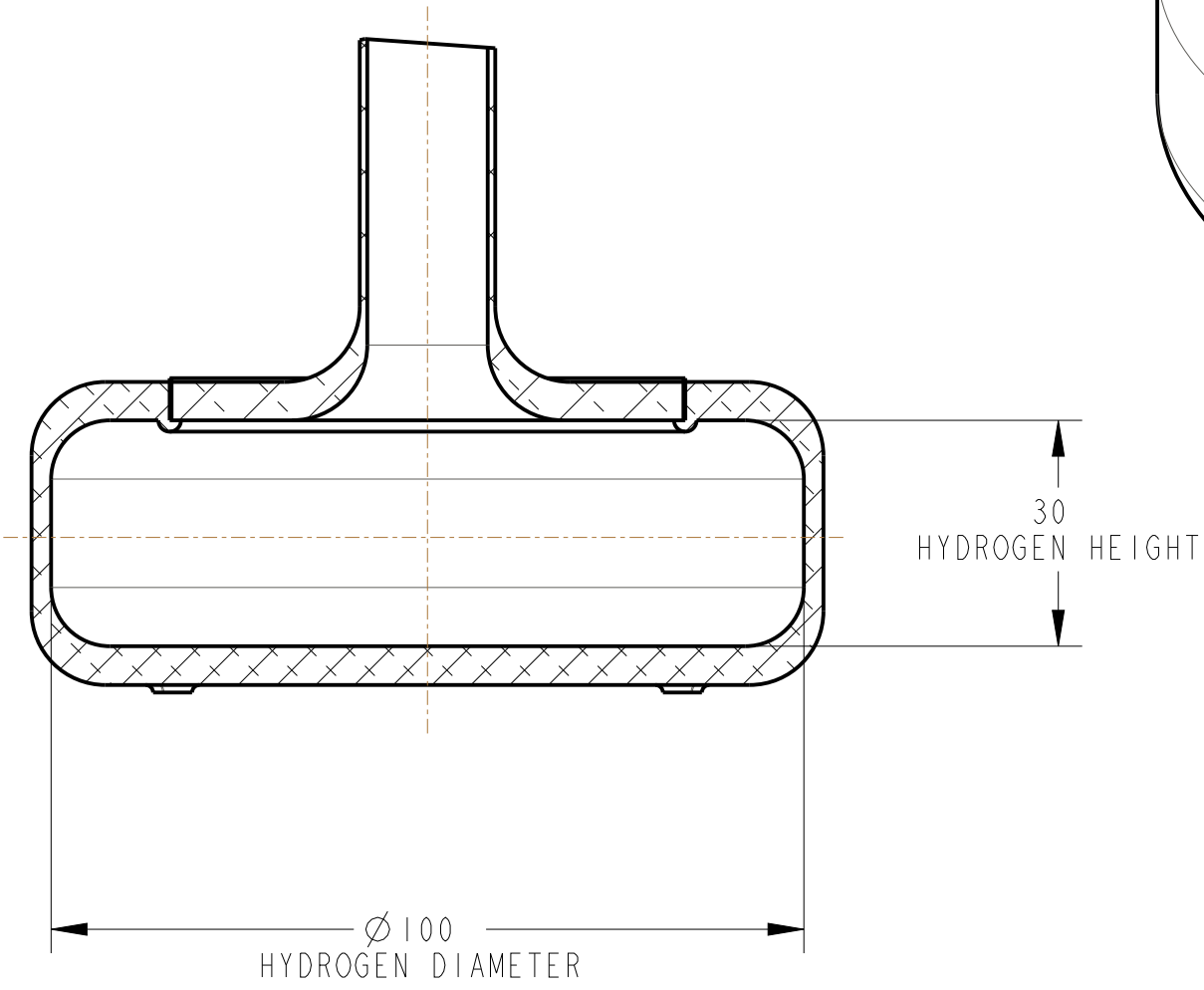
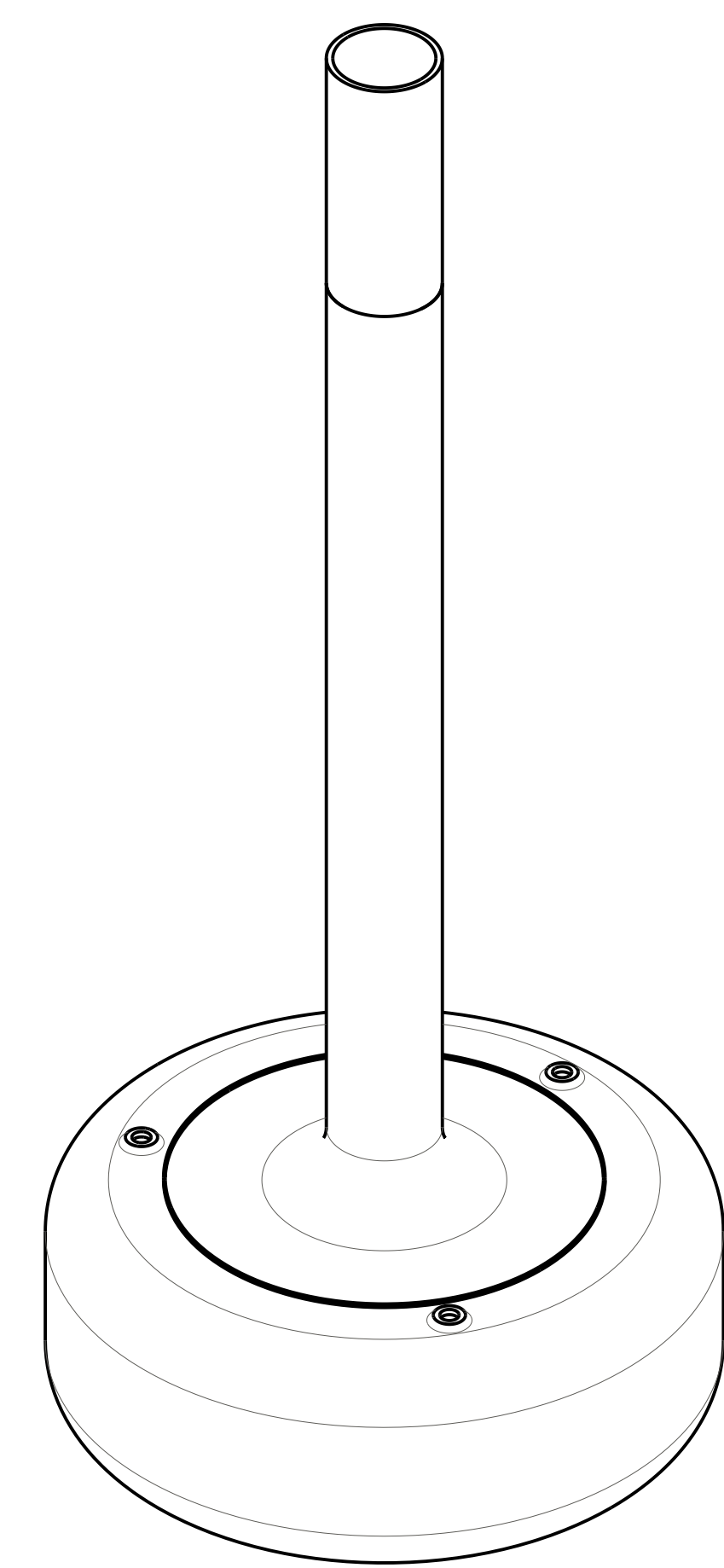
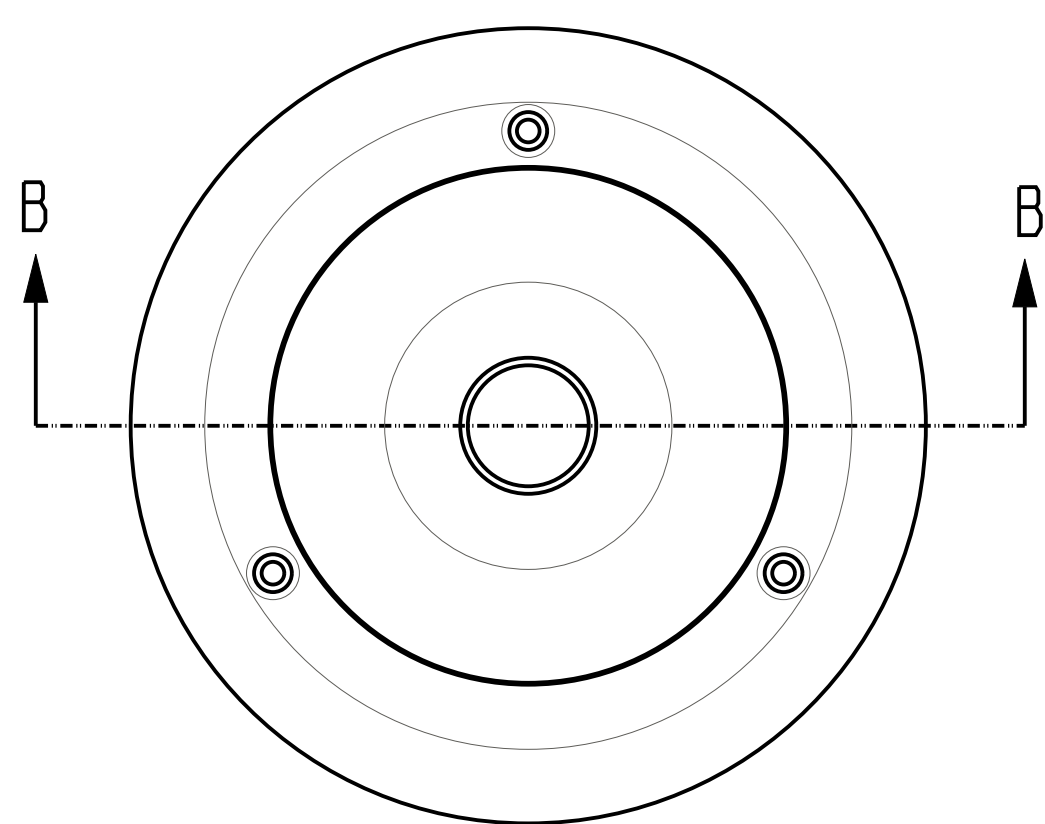

SECTION B-B

CYLINDER MODERATOR DETAIL
SCALE 1:1

SCALE 1:1

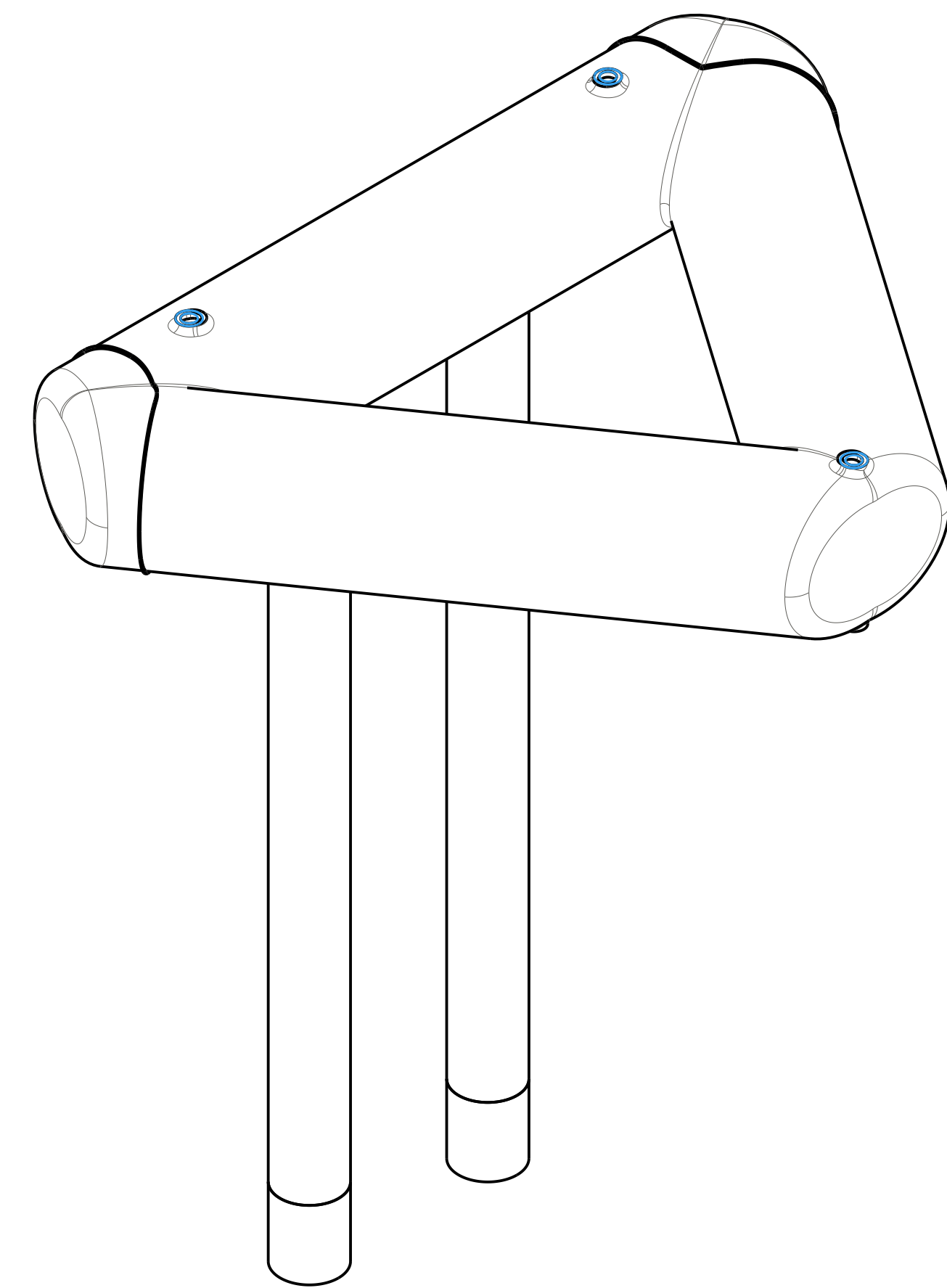
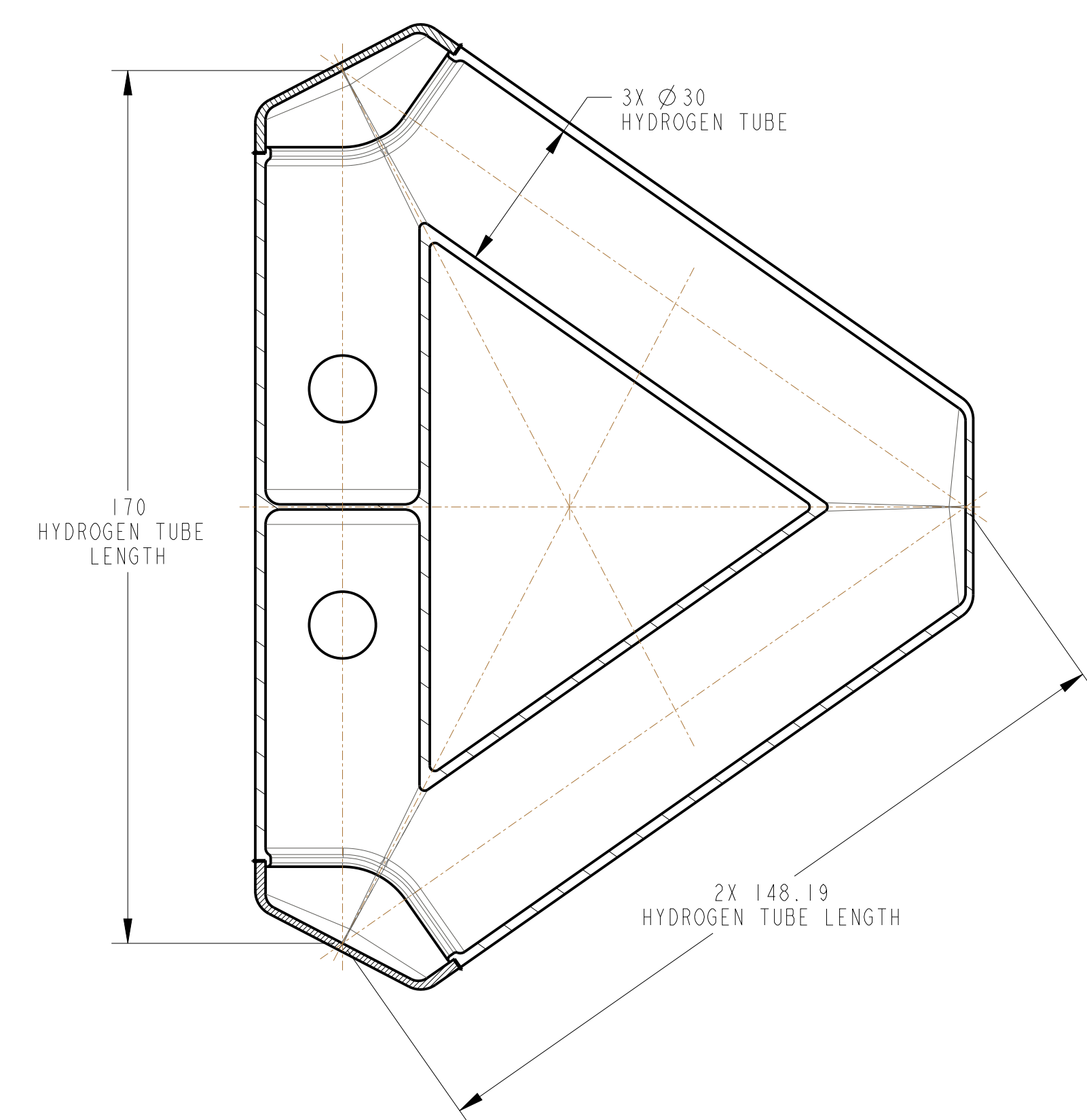

SCALE 1:1

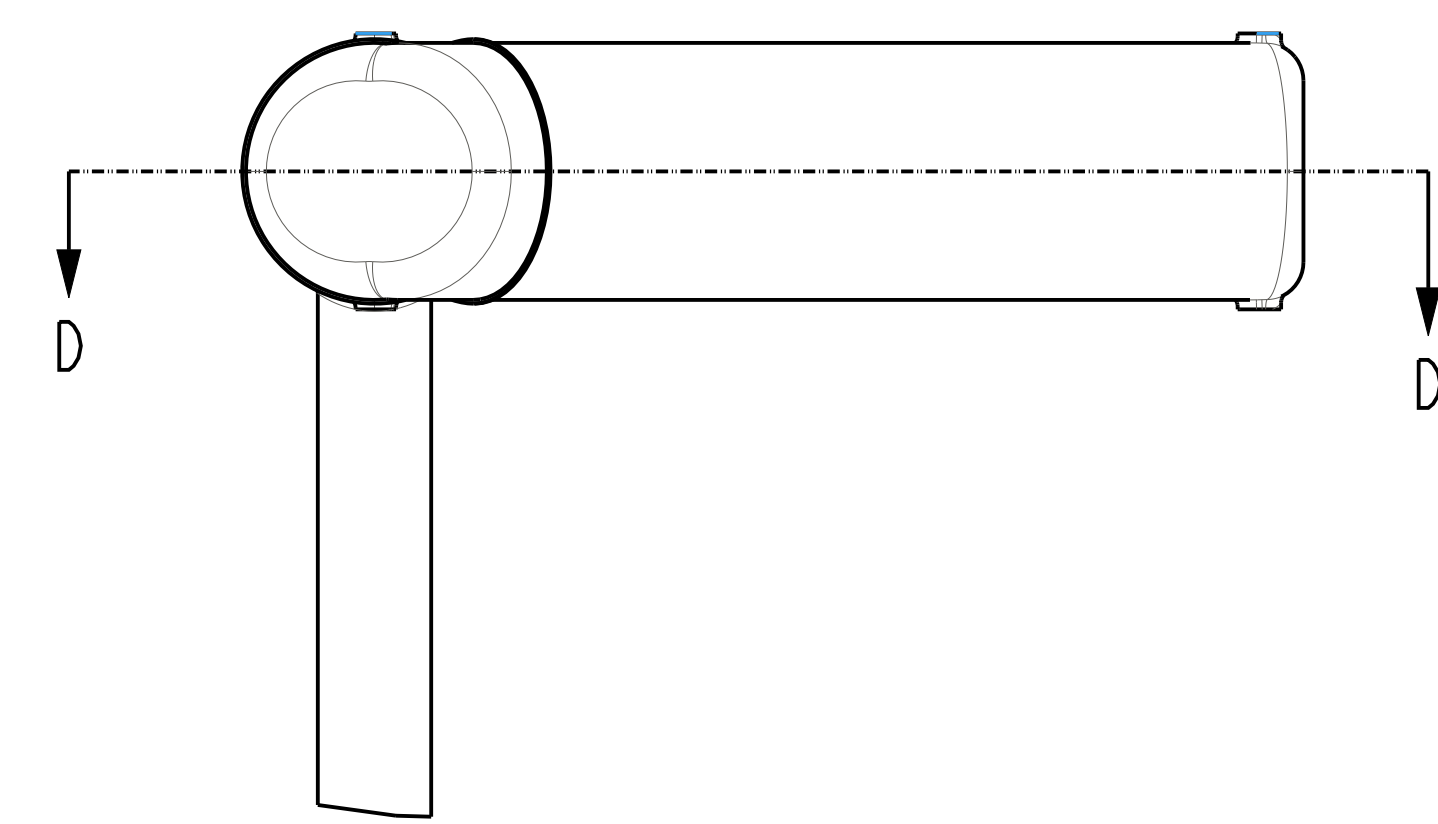

SECTION D-D

TUBE MODERATOR DETAIL
SCALE 1:1

SIZE	SCALE	SHEET	DRAWING NUMBER	REV
D	1:10	4 OF 5	S03040000-M8U-8800-A10000	A

8 7 6 5 4 3 2 1

8 7 6 5 4 3 2 1

D

D

C

C

B

B

A

A

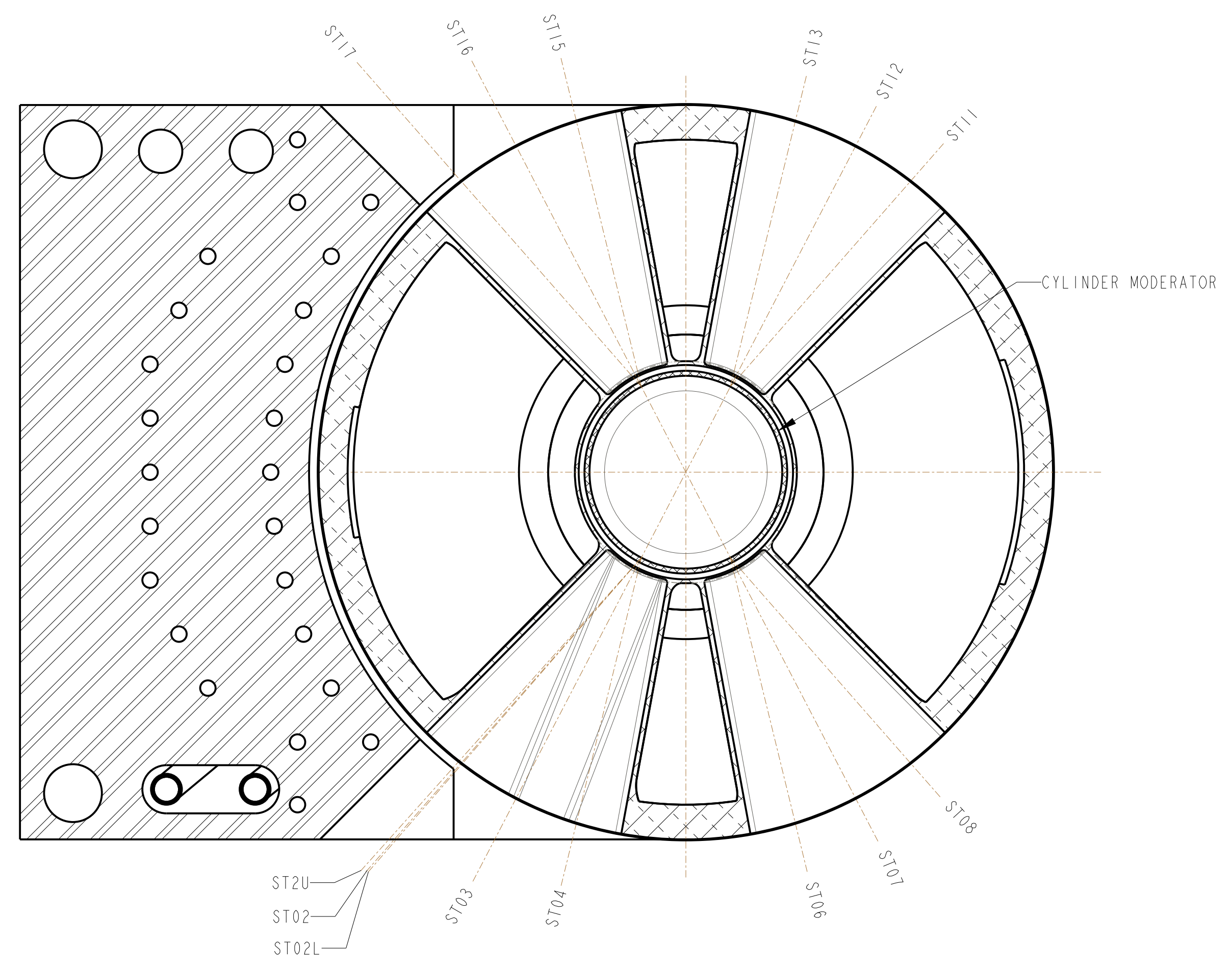

SECTION AT CYLINDER MODERATOR
 BEAMLINE REFERENCE
 SECTION C-C
 SCALE 1:2
 SEE SHEET 1

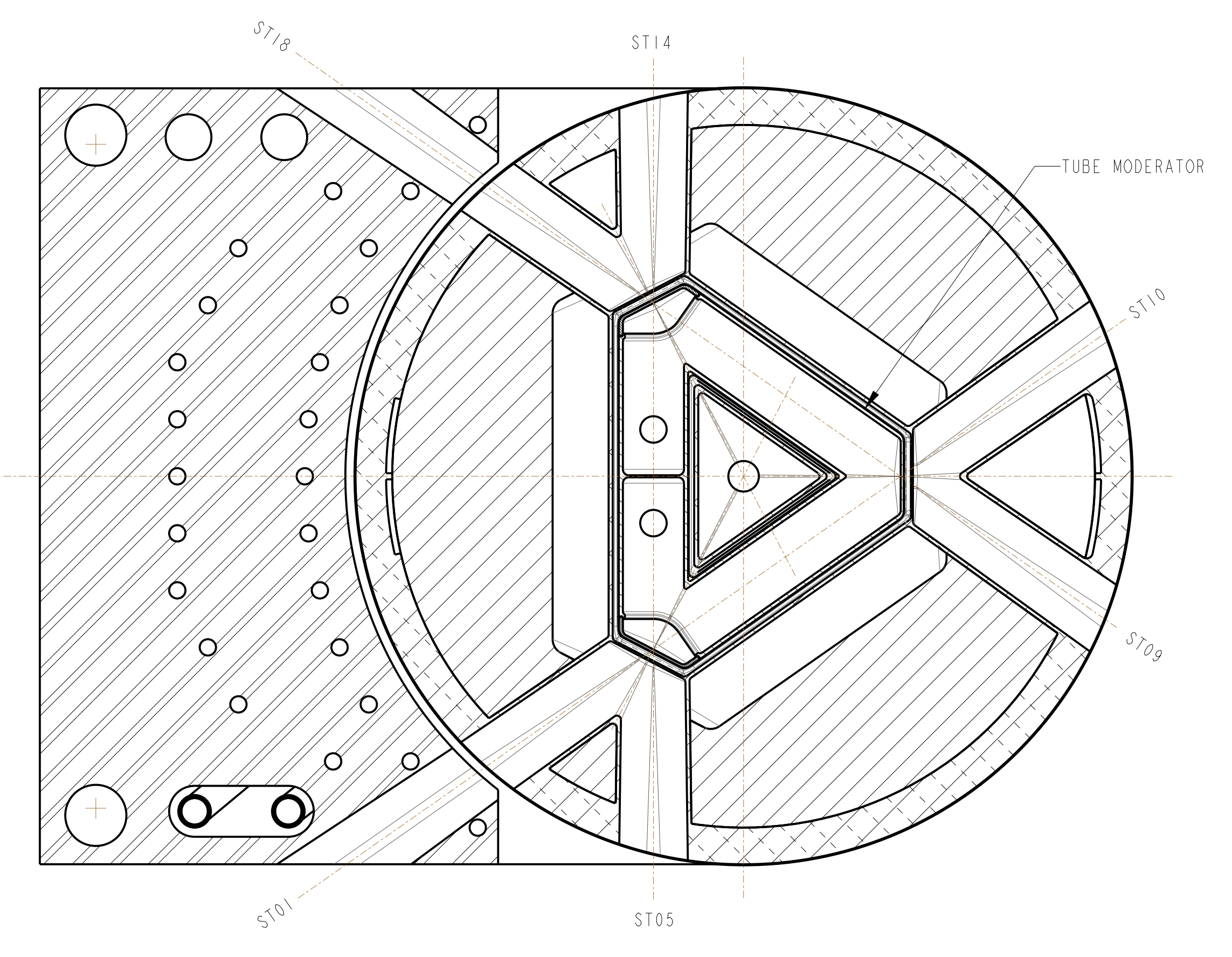

SECTION AT TUBE MODERATOR
 BEAMLINE REFERENCE
 SECTION D-D
 SCALE 1:2
 SEE SHEET 1

SIZE	SCALE	SHEET	DRAWING NUMBER	REV
D	1:10	5 OF 5	S03040000-M8U-8800-A10000	A

8 7 6 5 4 3 2 1