

8 7 6 5 4 3 2 1

NO REPRESENTATION OR WARRANTY, EXPRESSED OR IMPLIED, IS MADE AS TO THE ACCURACY, COMPLETENESS OR USEFULNESS OF THE INFORMATION OR STATEMENTS CONTAINED IN THESE DRAWINGS, OR THAT THE DISCLOSURE OF ANY INFORMATION, APPARATUS, METHOD OR PROCESS DISCLOSED IN THESE DRAWINGS MAY NOT INFRINGE PRIVATE RIGHTS OF OTHERS. NO LIABILITY IS ASSUMED WITH RESPECT TO THE USE OF, OR FOR DAMAGES RESULTING FROM THE USE OF, ANY INFORMATION, APPARATUS, METHOD OR PROCESS DISCLOSED IN THESE DRAWINGS. DRAWINGS MADE AVAILABLE FOR INFORMATION TO BIDDER ARE NOT TO BE USED FOR OTHER PURPOSES AND ARE TO BE RETURNED UPON REQUEST OF THE FORWARDING CONTRACTOR.

THIS DRAWING IS THE PROPERTY OF OAK RIDGE NATIONAL LABORATORY.

APPROVAL BLOCK

REV	DESCRIPTION OF CHANGE	DES	CHK	ENG	API	AP2	AP3	DATE
0	ORIGINAL ISSUE	KLW	WJT		VBG			02/28/2024
1	RESIVED POSITIONS OF INSTRUMENTS AND CHSS INSTRUMENT PIT WAS 1.7M DEEP	KLW	WJT		VBG			02/28/2024
2	ADDED MODERATOR DETAIL VIEWS, CHANGED DIMENSIONING SCHEME, MODIFIED QIKR PIT GEOMETRY	KLW	WJT		VBG	MES		04/19/2024
3	ADDED MISSING DIMENSION ON QIKR AND CHANGED OVERALL DIMENSION DECIMAL PLACES	KLW	WJT		VBG	MES		06/06/2024
4	MODIFIED EXPANSE AND QIKR PIT GEOMETRY. BWAVES AND CHSS PITS MERGED	KLW	WJT		VBG	MES		08/08/2024
5	CHANGED DIMENSIONING SCHEME ON QIKR AND EXPANSE, ADDED SHEETS AND VIEWS FOR GREATER DETAIL							

NOTES:

- ANGULAR DIMENSIONS ARE TAKEN FROM PROTON BEAM.
- ORTHOGONAL DIMENSIONS FOR PITS ARE TAKEN FROM THE VERTICAL SAMPLE CENTERLINE.
- ALL DEPTHS ARE TAKEN FROM INSTRUMENT FLOOR ELEVATION.
- THESE DIMENSIONS DEFINE SAMPLE CENTER AND FINAL STRAIGHT SECTION OF QIKR LOWER BEAMLINE. FOR FULL BEAM PATH DEFINITION SEE DRAWING S04020000-B8U-8840-A10000 INSTRUMENT CONTROL DRAWING.

D
C
B
A

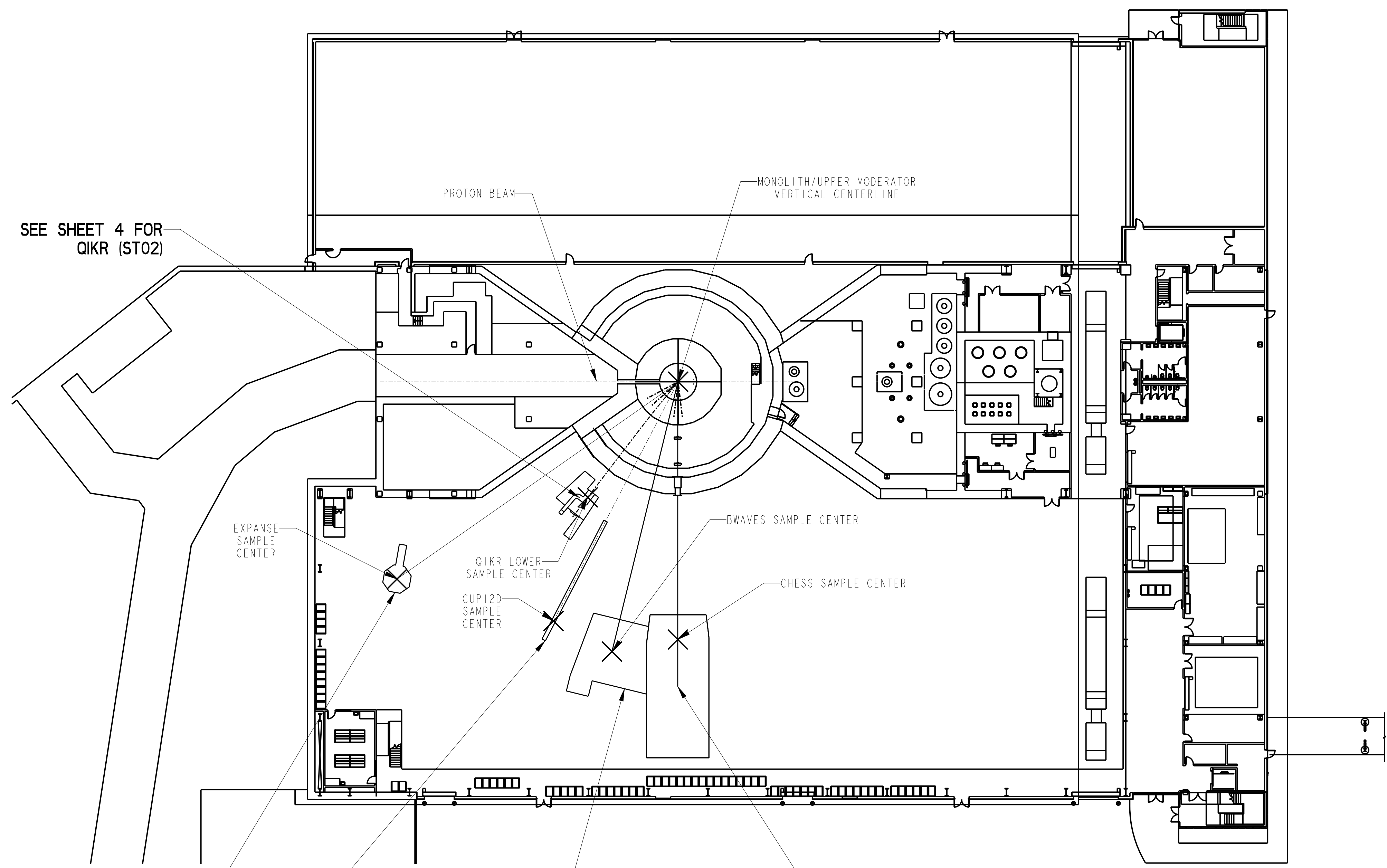

SEE SHEET 4 FOR QIKR (ST02)

EXPANSE SAMPLE CENTER

QIKR LOWER SAMPLE CENTER

CUPI2D SAMPLE CENTER

BWAVES SAMPLE CENTER

CHSS SAMPLE CENTER

SEE SHEET 7 FOR CUPI2D (ST03)

SEE SHEET 9 FOR CHSS (ST05)

SEE SHEET 2 FOR EXPANSE (ST01)

SEE SHEET 8 FOR BWAVES (ST04)

PRELIMINARY DRAWING
NOT TO BE USED FOR CONSTRUCTION

UNITS: MILLIMETERS		OAK RIDGE National Laboratory	HIGH FLUX ISOTOPE REACTOR SPALLATION NEUTRON SOURCE
DEFAULT TOLERANCES 0-6 ±0.1 >6-120 ±0.2 >120 ±0.5 ANGULAR ±0.5°			
BREAK ALL SHARP EDGES EXCEPT AS NOTED: 15 MAX SURFACE ROUGHNESS: 3.2 Ra UNO.		SECOND TARGET STATION INTERFACE CONTROL DRAWING INSTRUMENT PITS	
DRAFTING STD: ASME Y14.100 D & T: ASME Y14.5 WELD SYMBOLS: AWS A2.4			
THIRD ANGLE PROJECTION		DRAWING NUMBER S04010100-C8U-8800-A10000	REV 5
SIZE D	SCALE 1:1600	WEIGHT N/A	SHEET 1 of 9

8 7 6 5 4 3 2 1

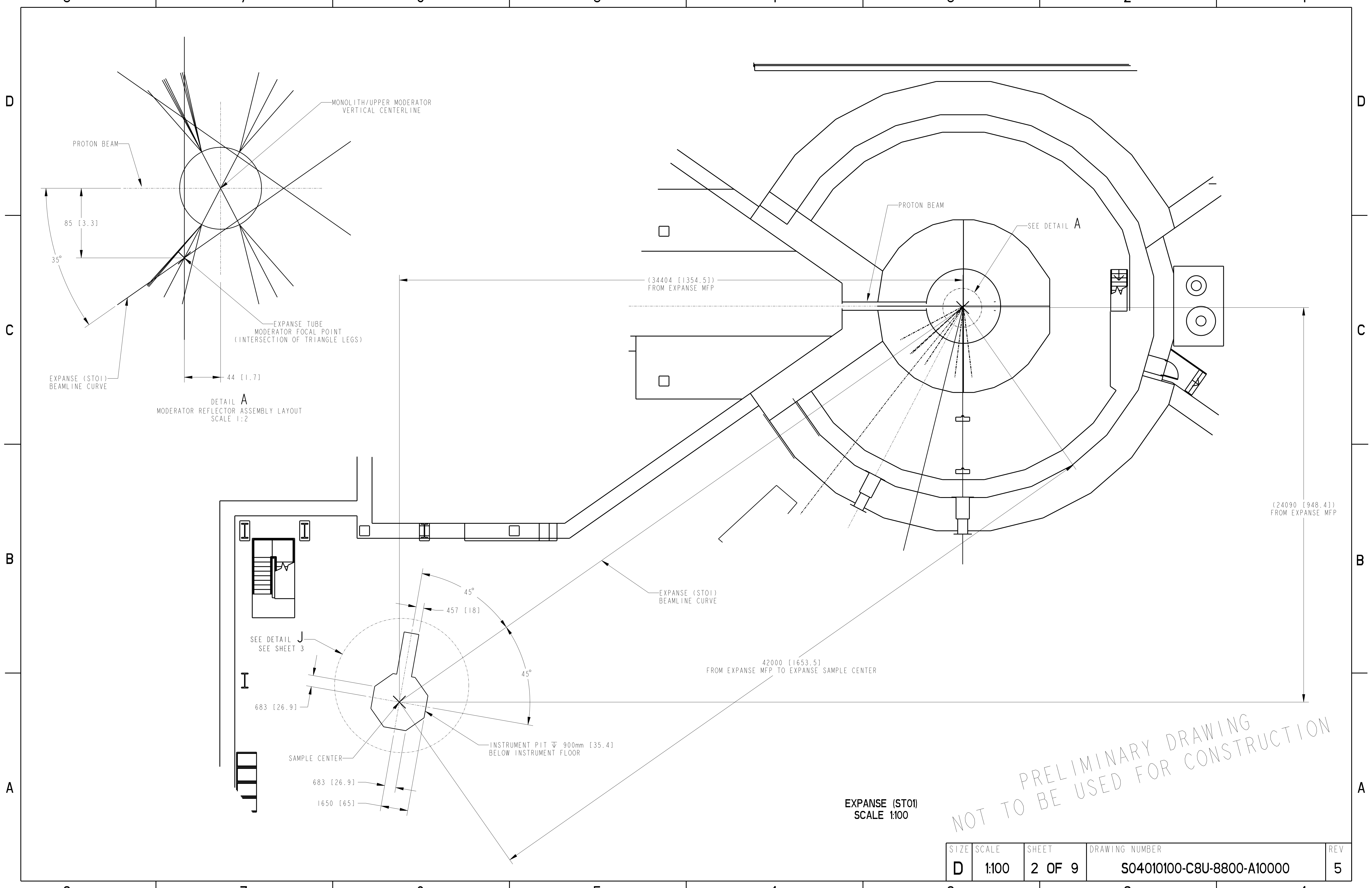

DETAIL A
MODERATOR REFLECTOR ASSEMBLY LAYOUT
SCALE 1:2

EXPANCE (ST01)
SCALE 1:100

PRELIMINARY DRAWING
NOT TO BE USED FOR CONSTRUCTION

SIZE	SCALE	SHEET	DRAWING NUMBER	REV
D	1:100	2 OF 9	S04010100-C8U-8800-A10000	5

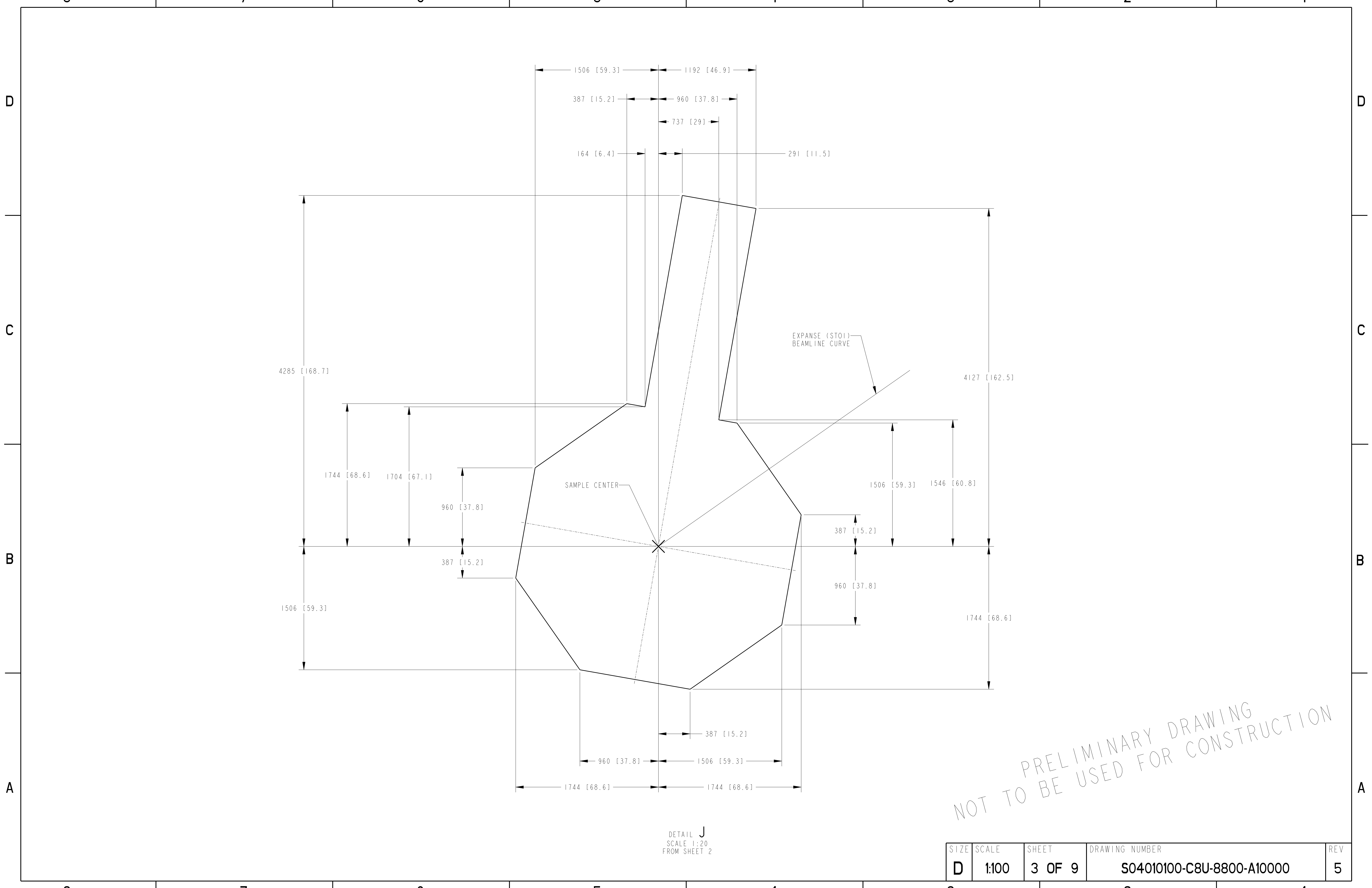

PRELIMINARY DRAWING
NOT TO BE USED FOR CONSTRUCTION

DETAIL J
SCALE 1:20
FROM SHEET 2

SIZE	SCALE	SHEET	DRAWING NUMBER	REV
D	1:100	3 OF 9	S04010100-C8U-8800-A10000	5

8 7 6 5 4 3 2 1

D
C
B
A

D
C
B
A

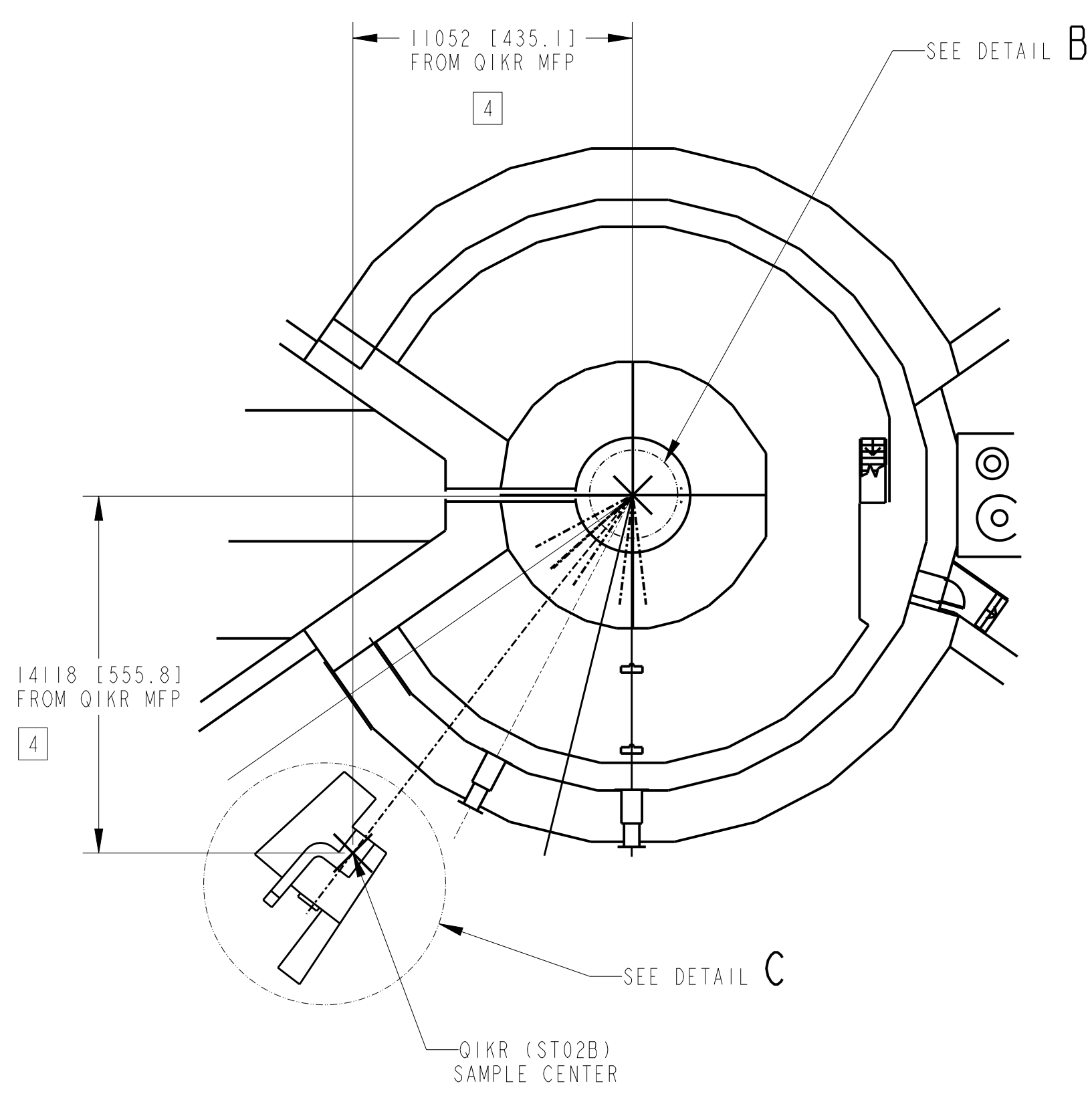

QIKR (ST02)
SCALE 1:200

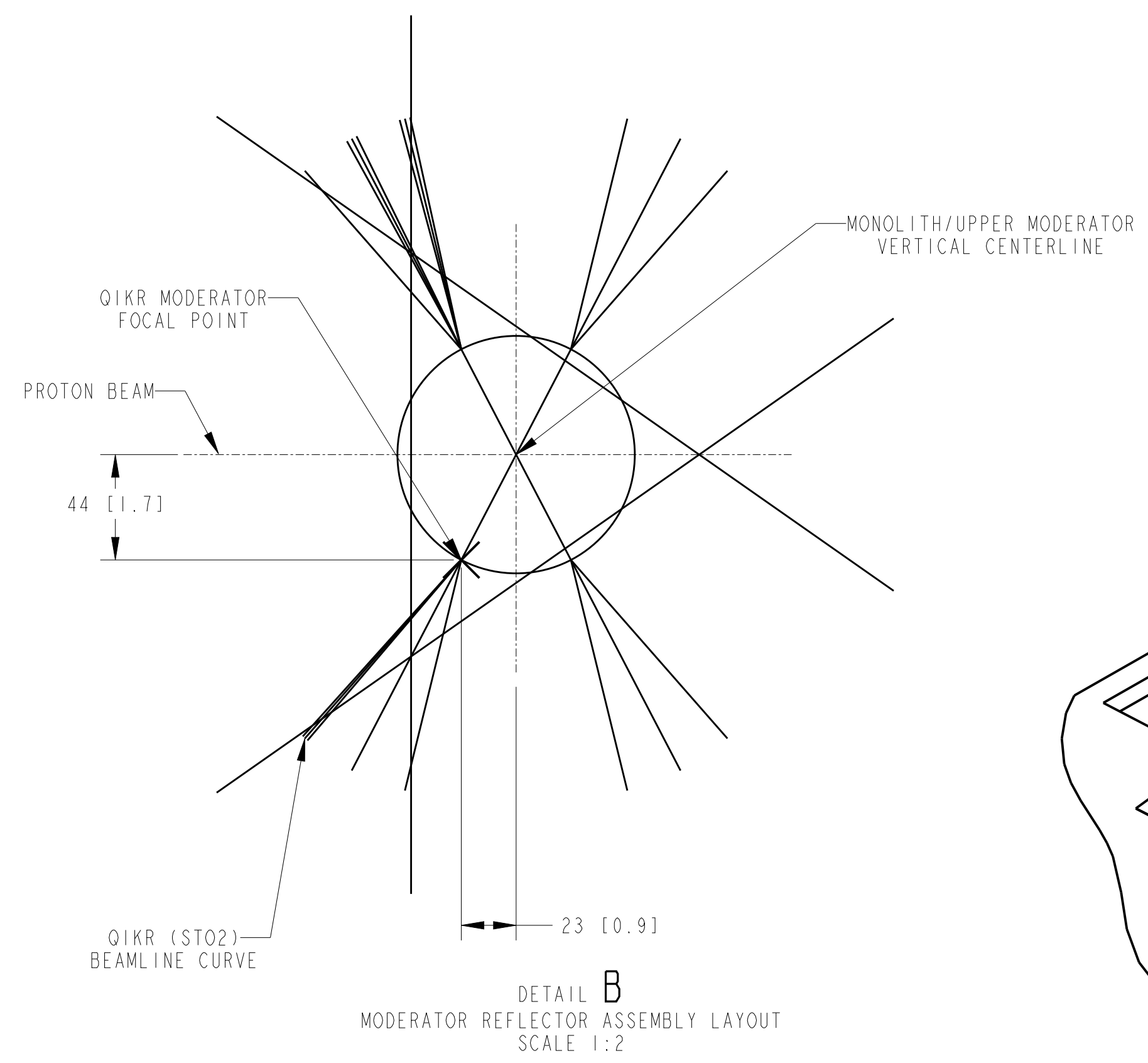

DETAIL B
MODERATOR REFLECTOR ASSEMBLY LAYOUT
SCALE 1:2

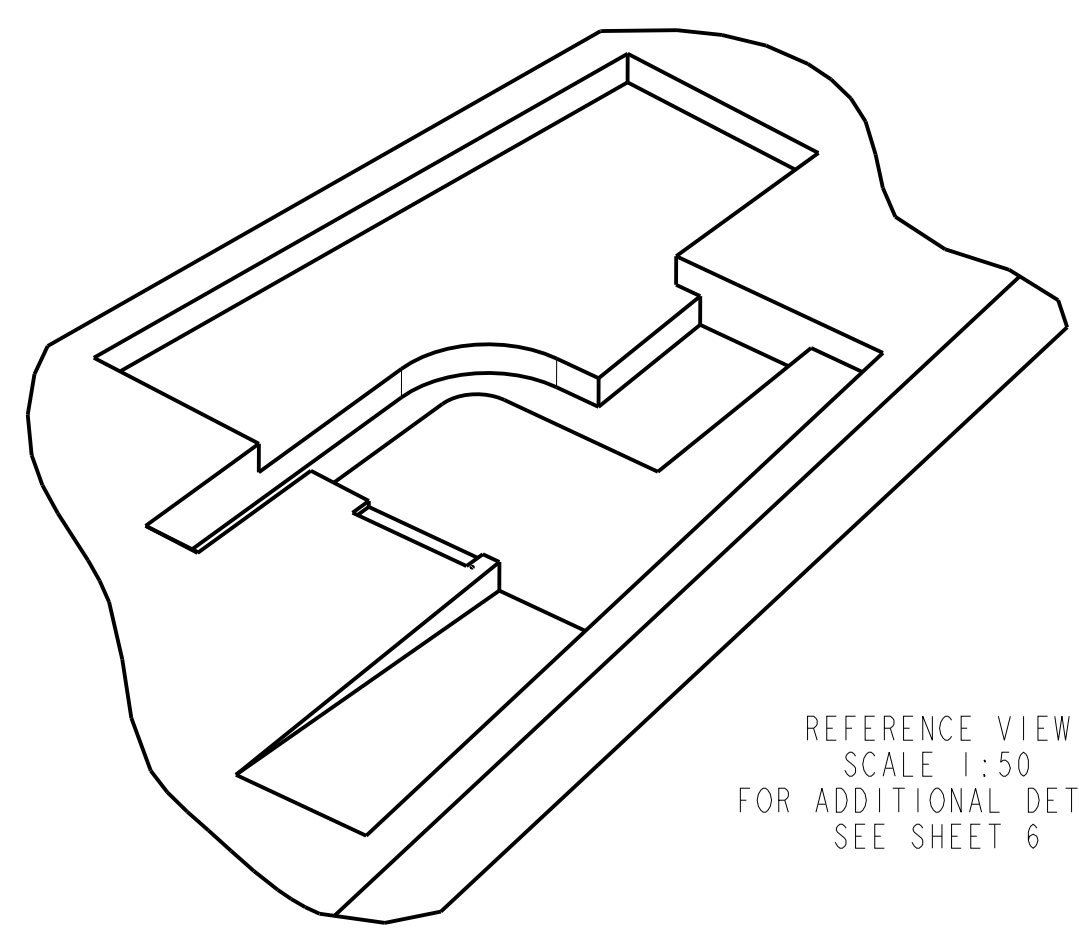

REFERENCE VIEW
SCALE 1:50
FOR ADDITIONAL DETAIL
SEE SHEET 6

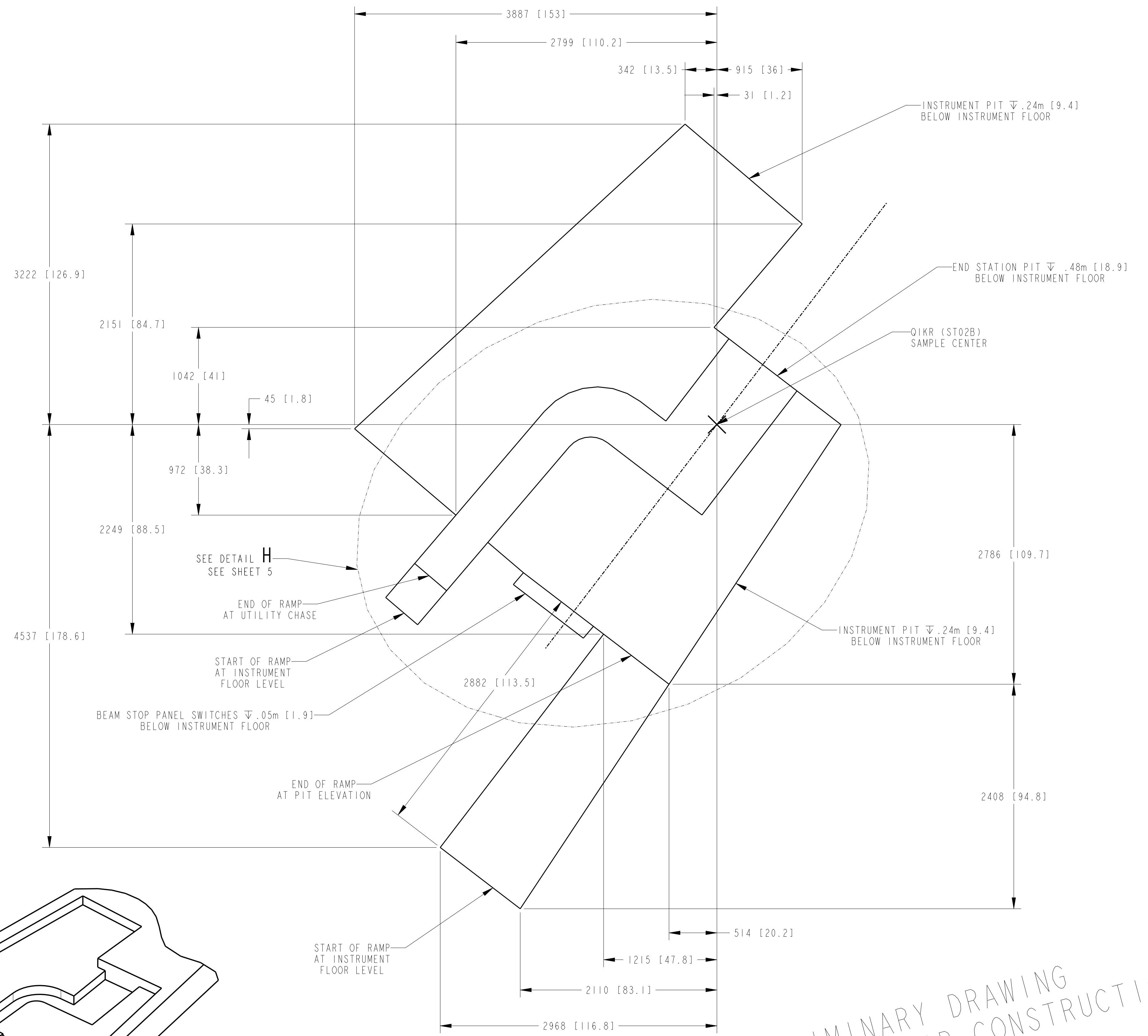

DETAIL C
SCALE 1:25

PRELIMINARY DRAWING
NOT TO BE USED FOR CONSTRUCTION

SIZE	SCALE	SHEET	DRAWING NUMBER	REV
D	1:1600	4 OF 9	S04010100-C8U-8800-A10000	5

8 7 6 5 4 3 2 1

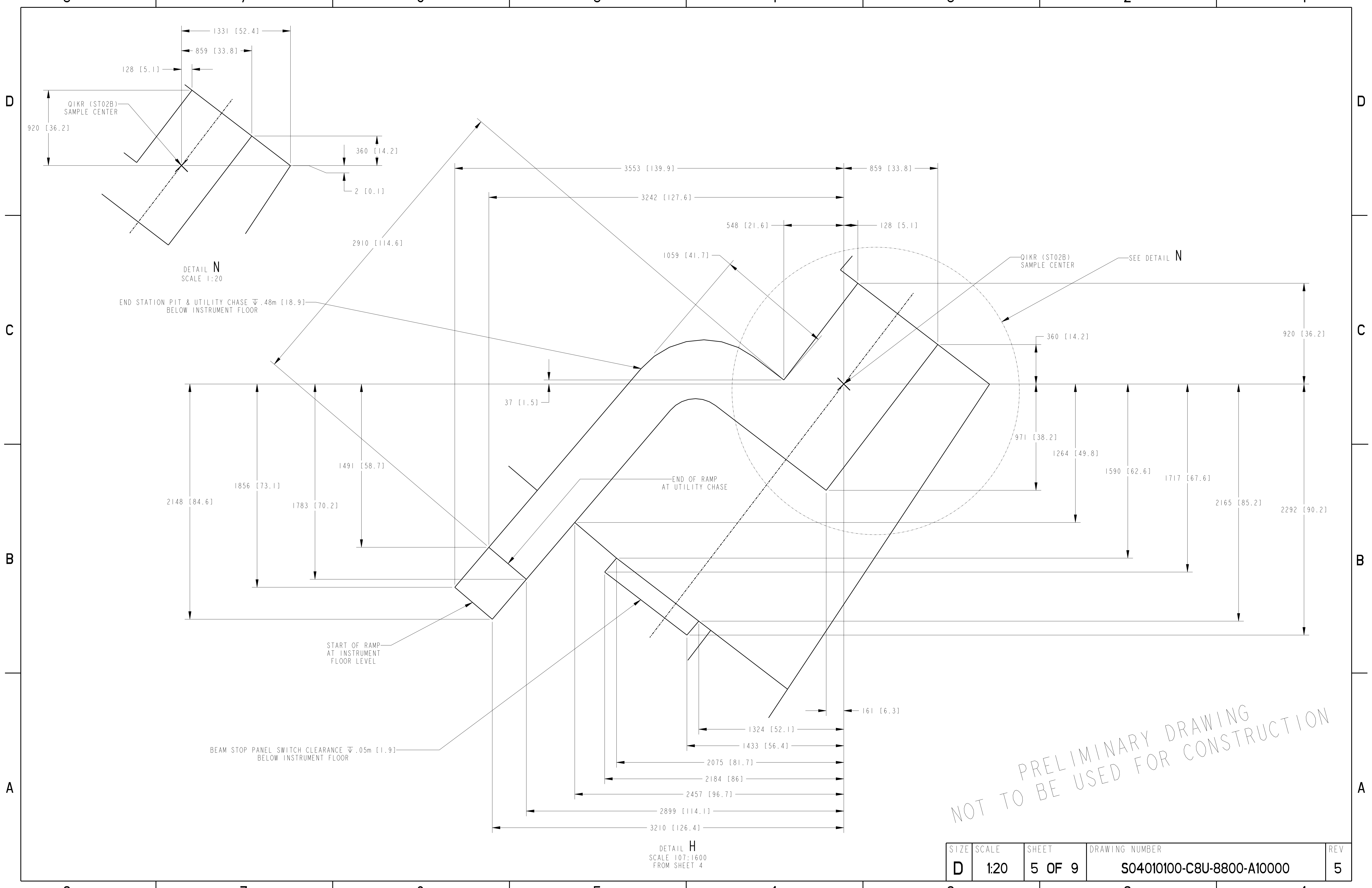

DETAIL N
SCALE 1:20

END STATION PIT & UTILITY CHASE ∇ .48m [18.9]
BELOW INSTRUMENT FLOOR

DETAIL H
SCALE 107:1600
FROM SHEET 4

PRELIMINARY DRAWING
NOT TO BE USED FOR CONSTRUCTION

SIZE	SCALE	SHEET	DRAWING NUMBER	REV
D	1:20	5 OF 9	S04010100-C8U-8800-A10000	5

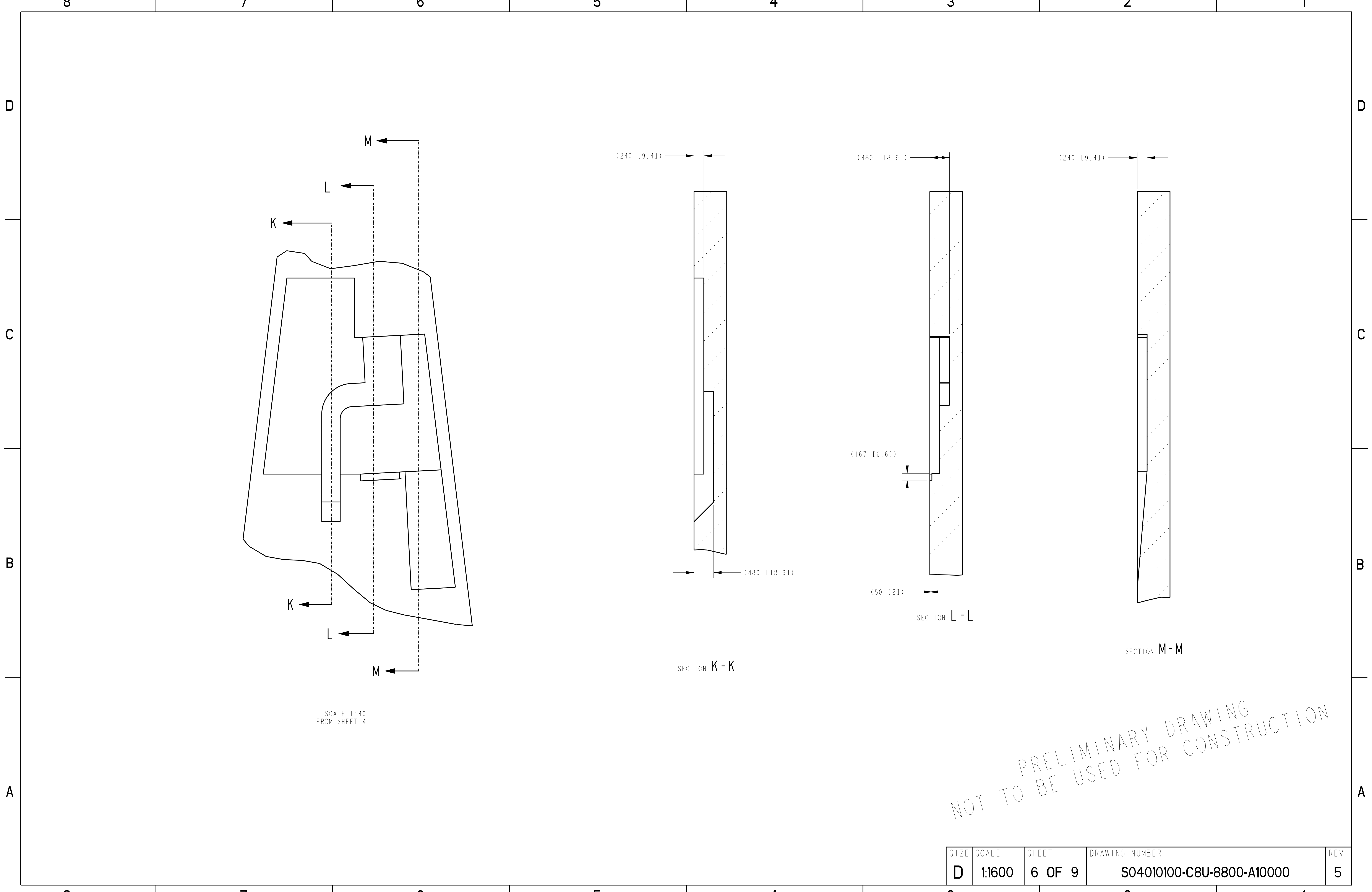

SCALE 1:40
FROM SHEET 4

SECTION K-K

SECTION L-L

SECTION M-M

PRELIMINARY DRAWING
NOT TO BE USED FOR CONSTRUCTION

SIZE	SCALE	SHEET	DRAWING NUMBER	REV
D	1:1600	6 OF 9	S04010100-C8U-8800-A10000	5

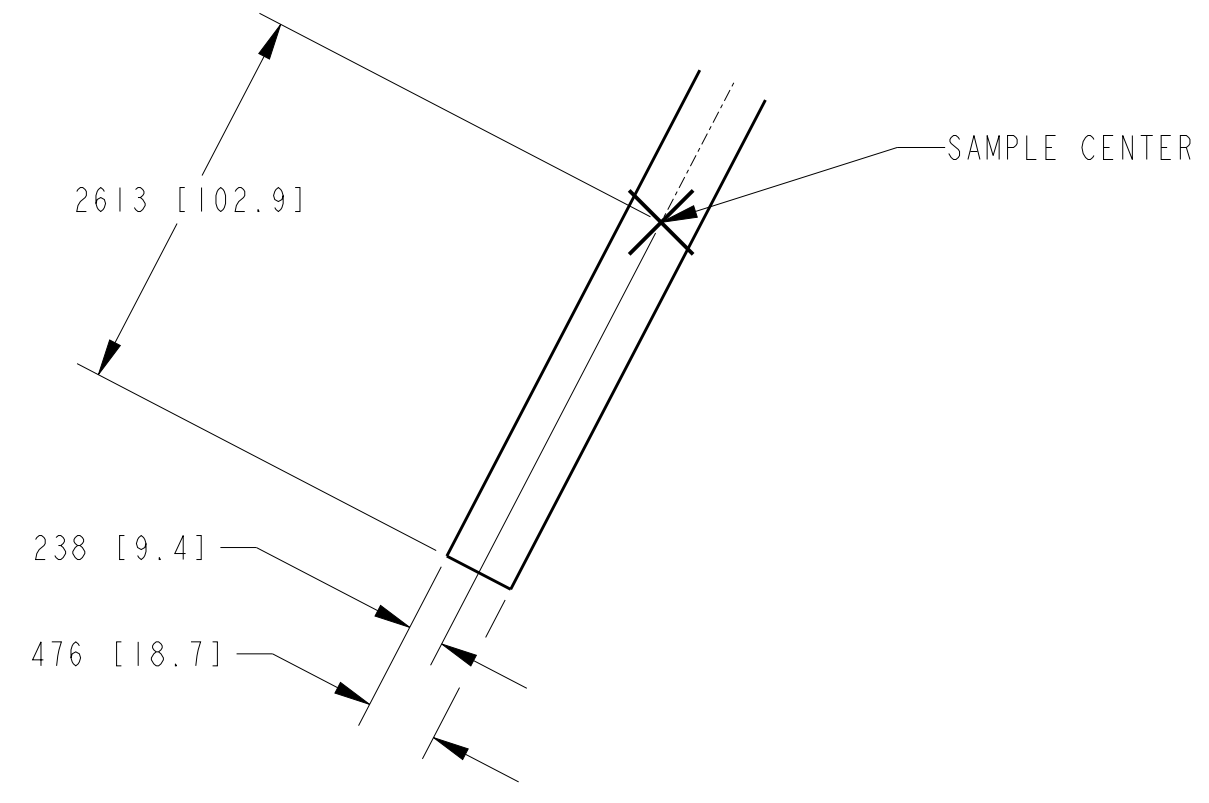
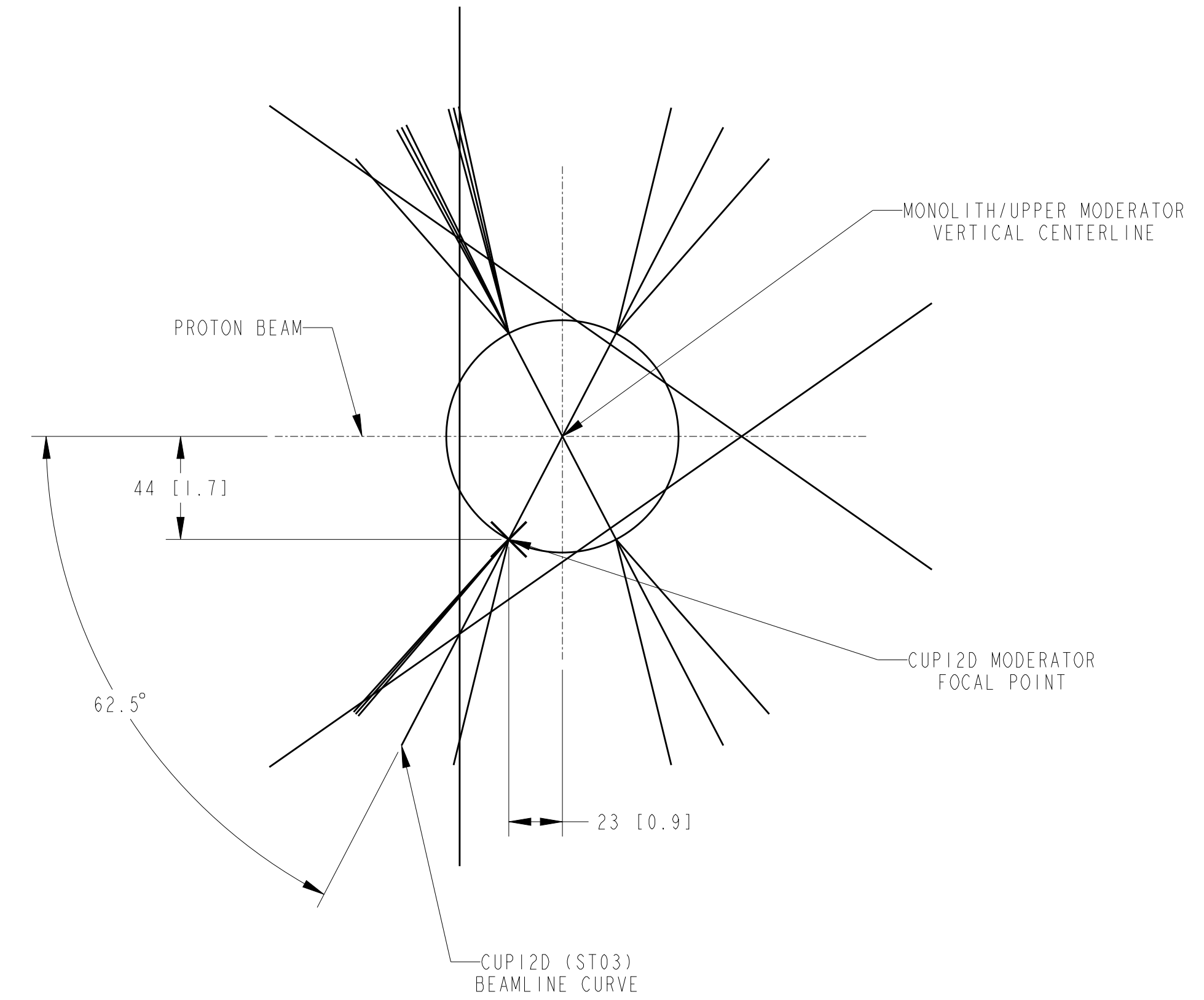
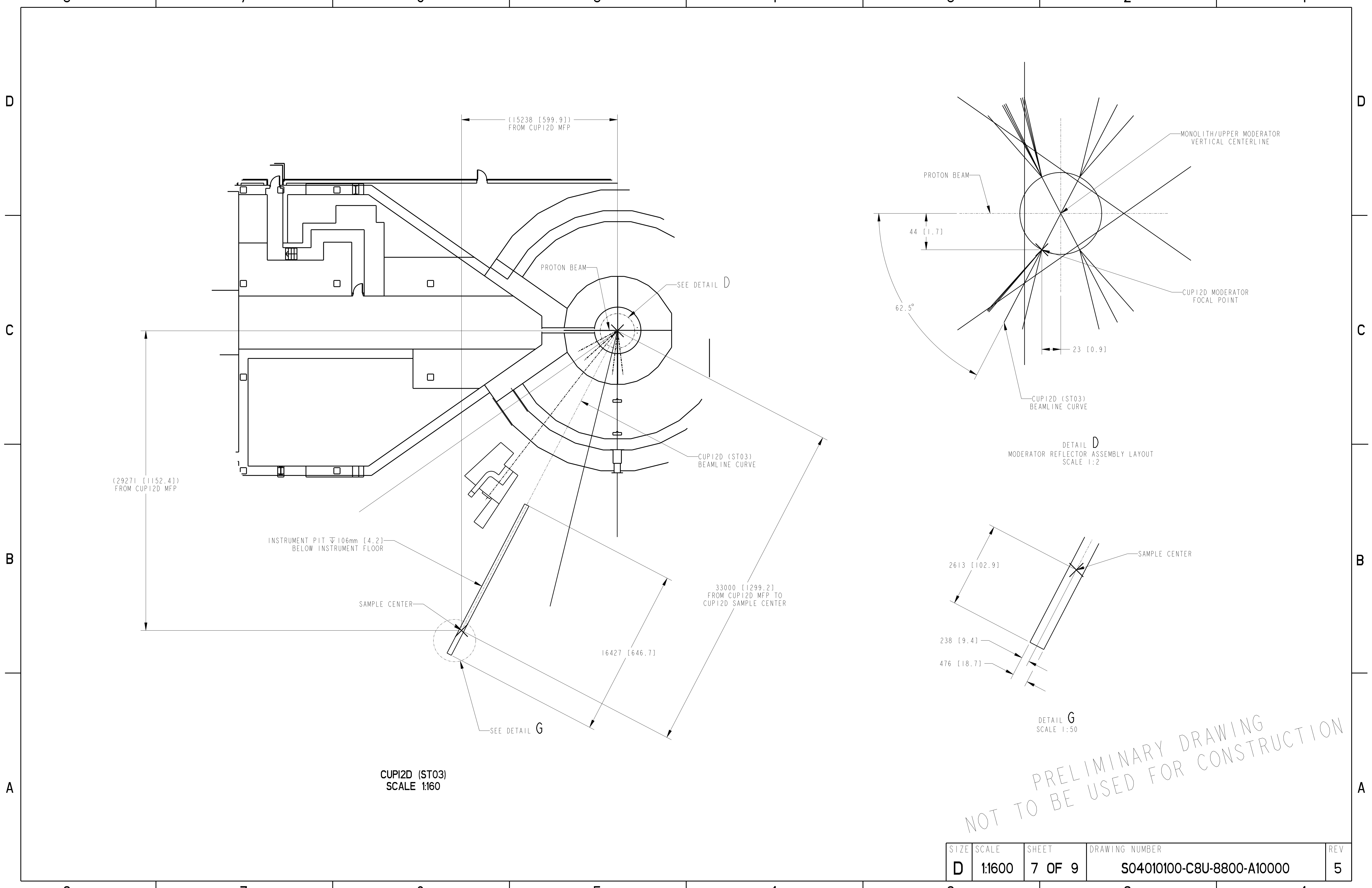

CUP12D (ST03)
SCALE 1:160

DETAIL D
MODERATOR REFLECTOR ASSEMBLY LAYOUT
SCALE 1:2

DETAIL G
SCALE 1:50

PRELIMINARY DRAWING
NOT TO BE USED FOR CONSTRUCTION

SIZE	SCALE	SHEET	DRAWING NUMBER	REV
D	1:1600	7 OF 9	S04010100-C8U-8800-A10000	5

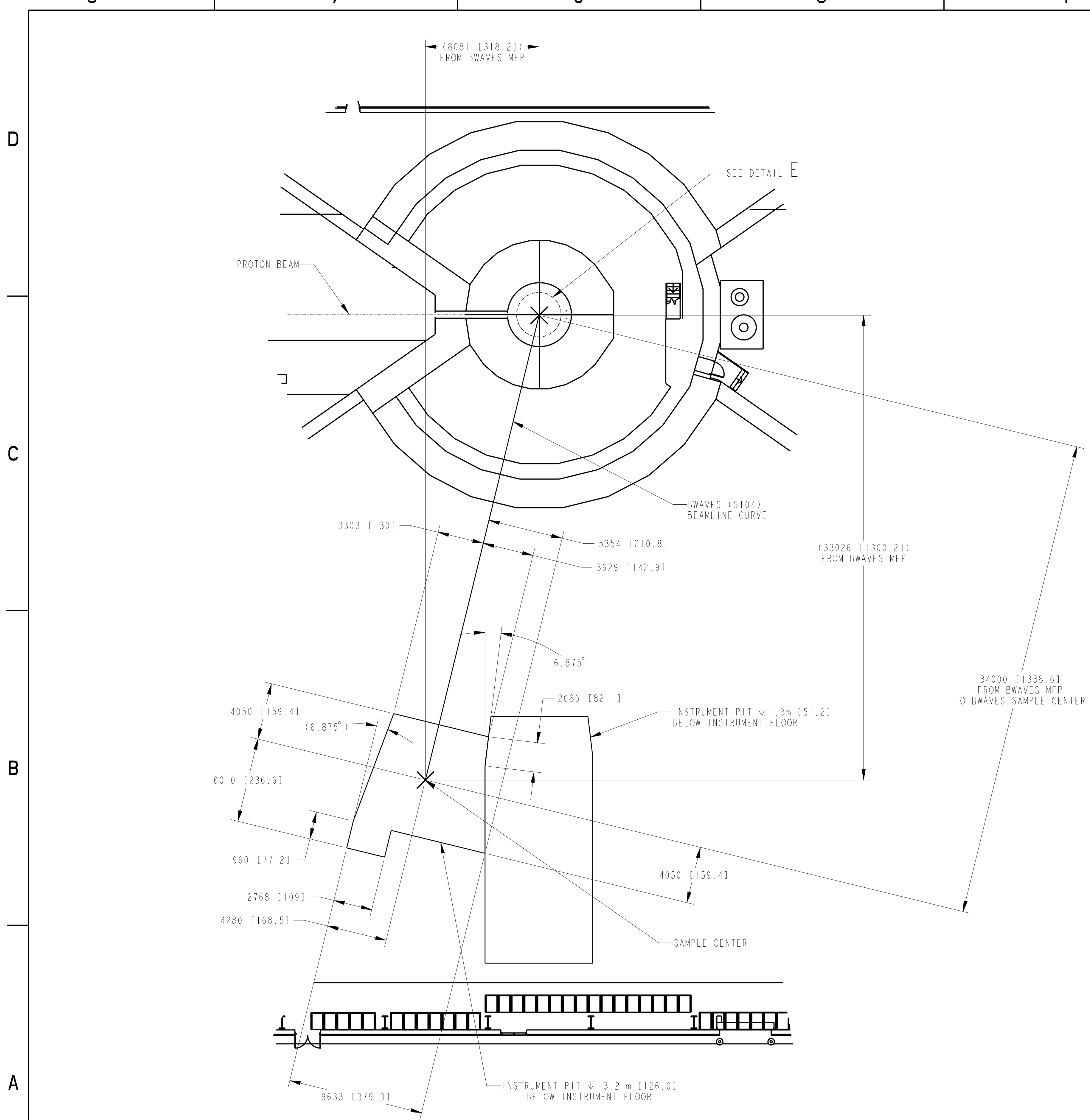

BWAVES (ST04)
SCALE 1:160

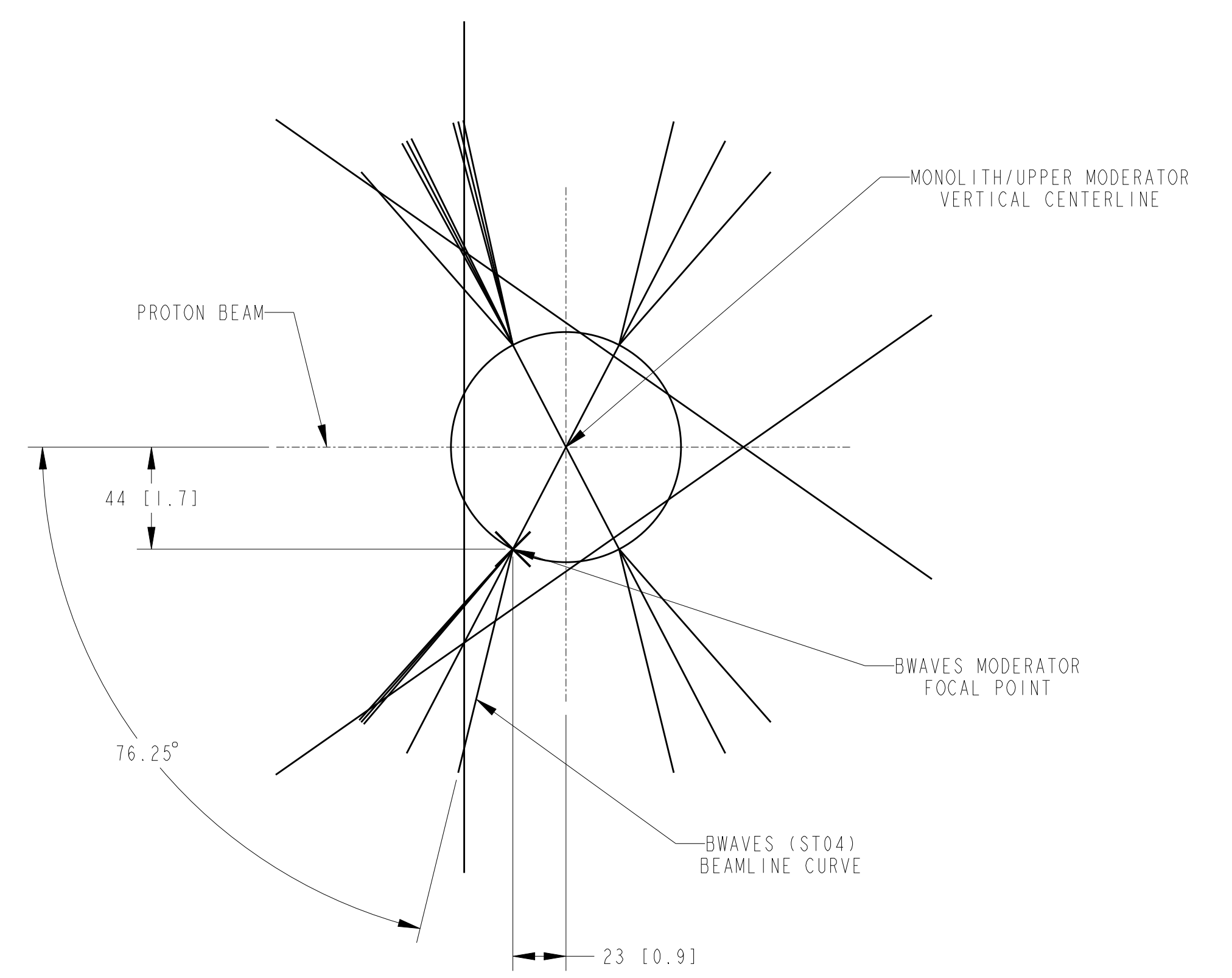

DETAIL E
MODERATOR REFLECTOR ASSEMBLY LAYOUT
SCALE 1:2

PRELIMINARY DRAWING
 NOT TO BE USED FOR CONSTRUCTION

SIZE	SCALE	SHEET	DRAWING NUMBER	REV
D	1:1600	8 OF 9	S04010100-C8U-8800-A10000	5

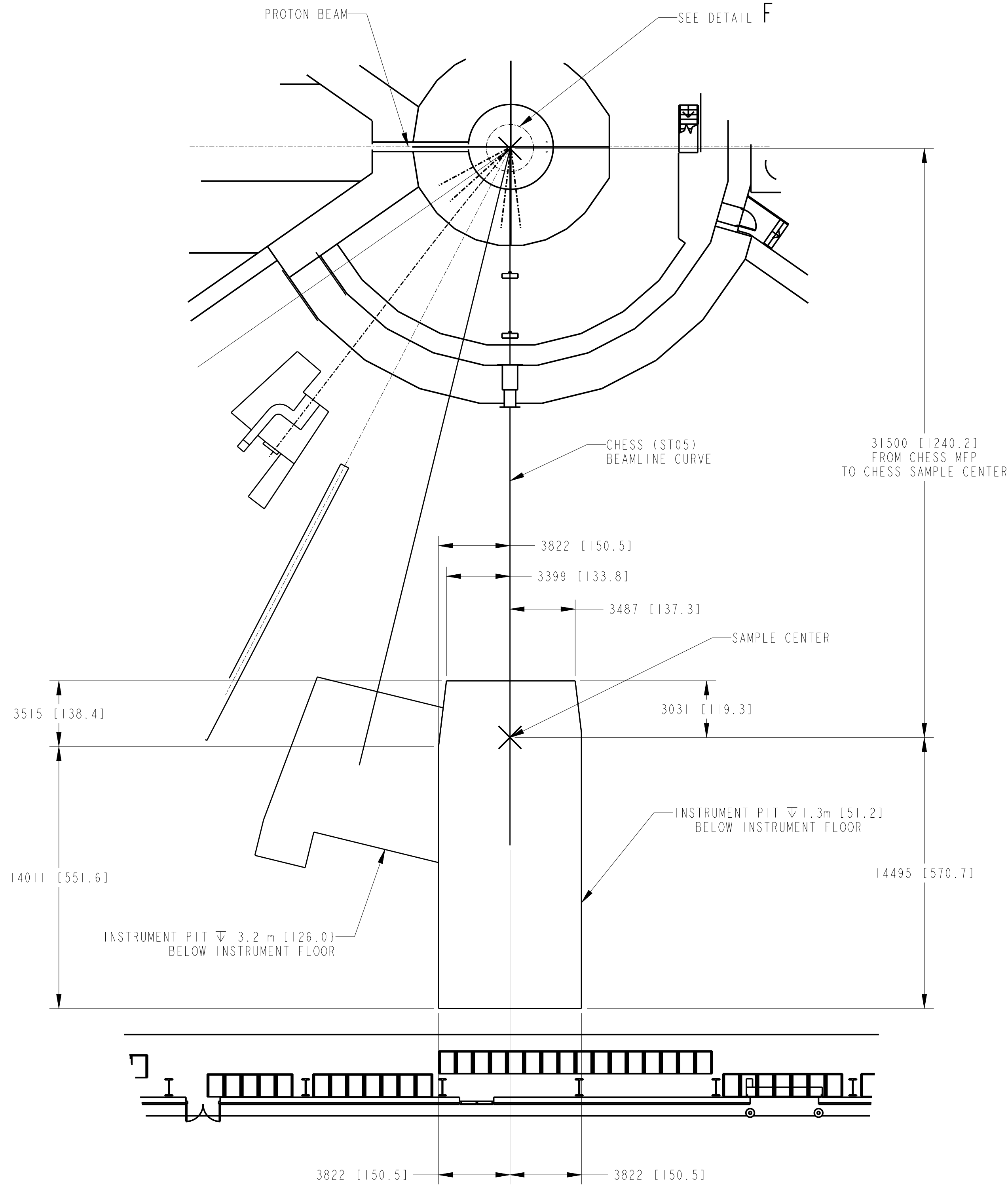

CHES (ST05)
SCALE 1:160

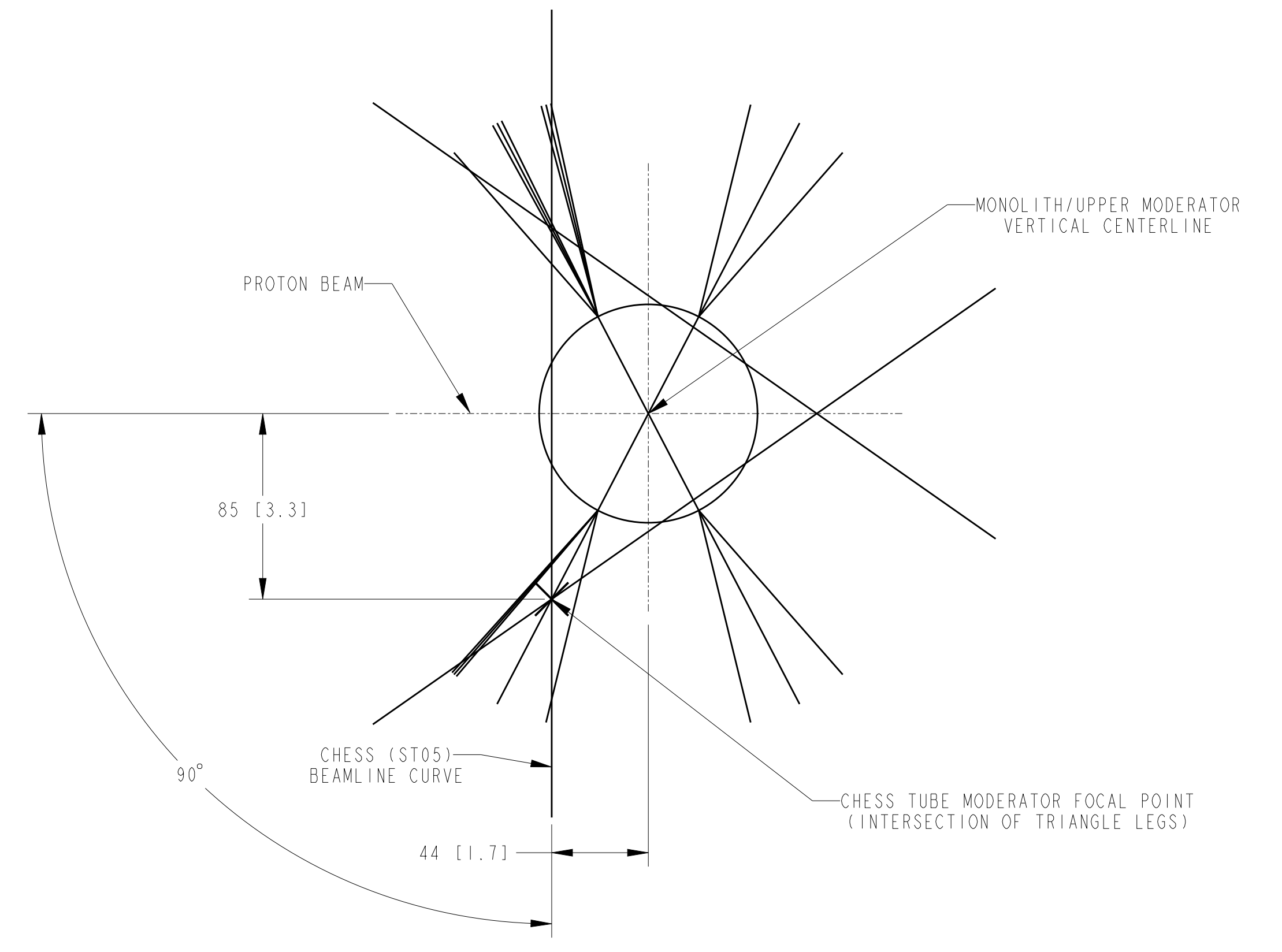

DETAIL F
MODERATOR REFLECTOR ASSEMBLY LAYOUT
SCALE 1:2

PRELIMINARY DRAWING
NOT TO BE USED FOR CONSTRUCTION

SIZE	SCALE	SHEET	DRAWING NUMBER	REV
D	1:1600	9 OF 9	S04010100-C8U-8800-A10000	5