



March 30, 2026 | Bldg 8600 Rm C-156

General Introduction to Neutron Polarization Technique

Barry Winn, HYSPEC Instrument Scientist

**Polarized Neutron Diffraction and
Spectroscopy: Applications to Quantum
Materials**

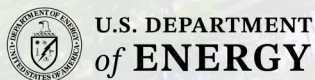

**U.S. DEPARTMENT
of ENERGY**

ORNL IS MANAGED BY UT-BATTELLE LLC
FOR THE US DEPARTMENT OF ENERGY

Character
Contrast
Configuration
Capability



Who uses polarized neutrons at SNS?

Magnetic Moment Contrast

Nuclear Spin Contrast

Enhanced Resolution via 'Larmor' Techniques

Studies of the neutron itself

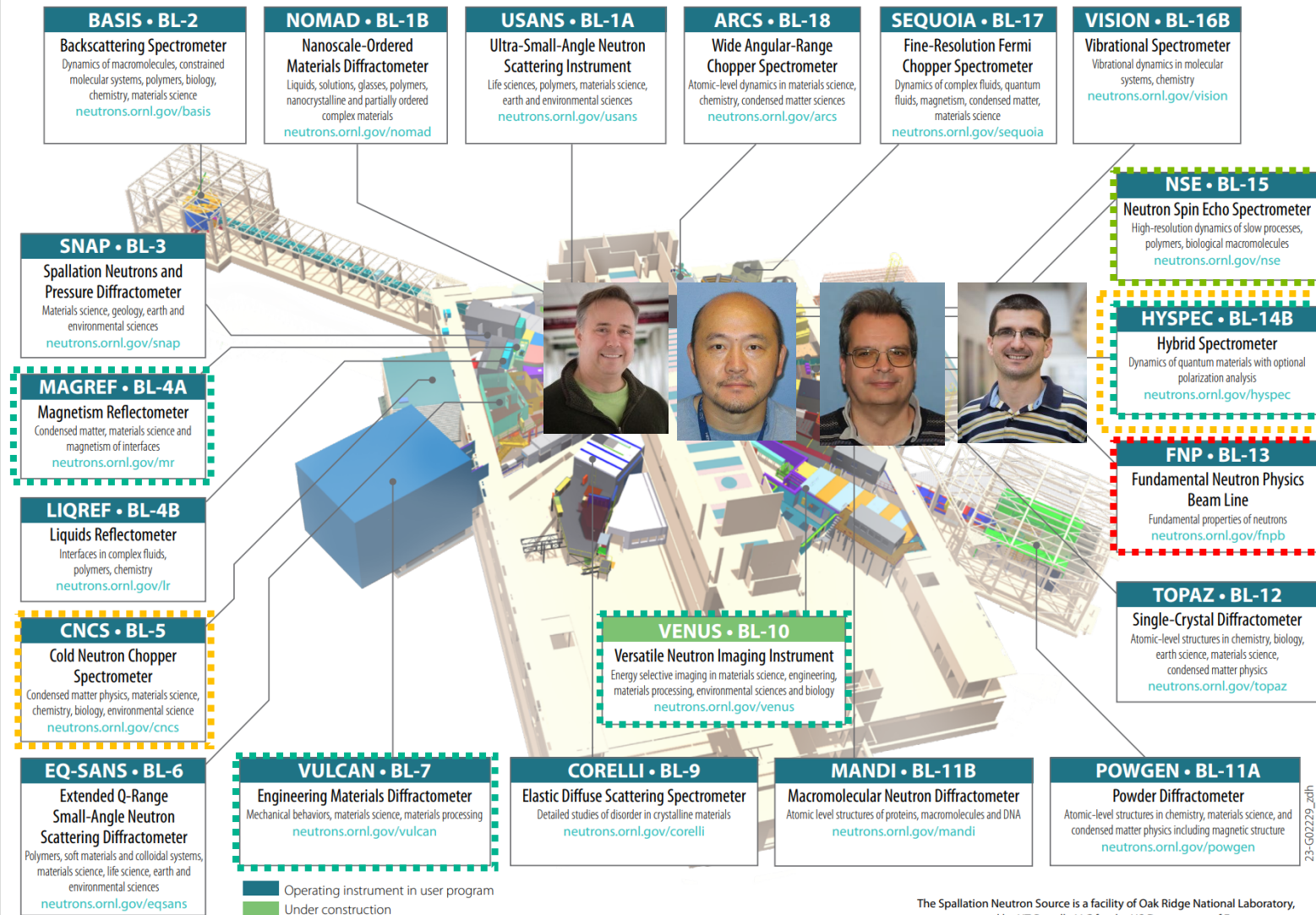

The Spallation Neutron Source is a facility of Oak Ridge National Laboratory, managed by UT-Battelle LLC for the US Department of Energy.

Who uses polarized neutrons at HFIR?

Magnetic Moment Contrast

Nuclear Spin Contrast

Enhanced resolution via 'Larmor' techniques

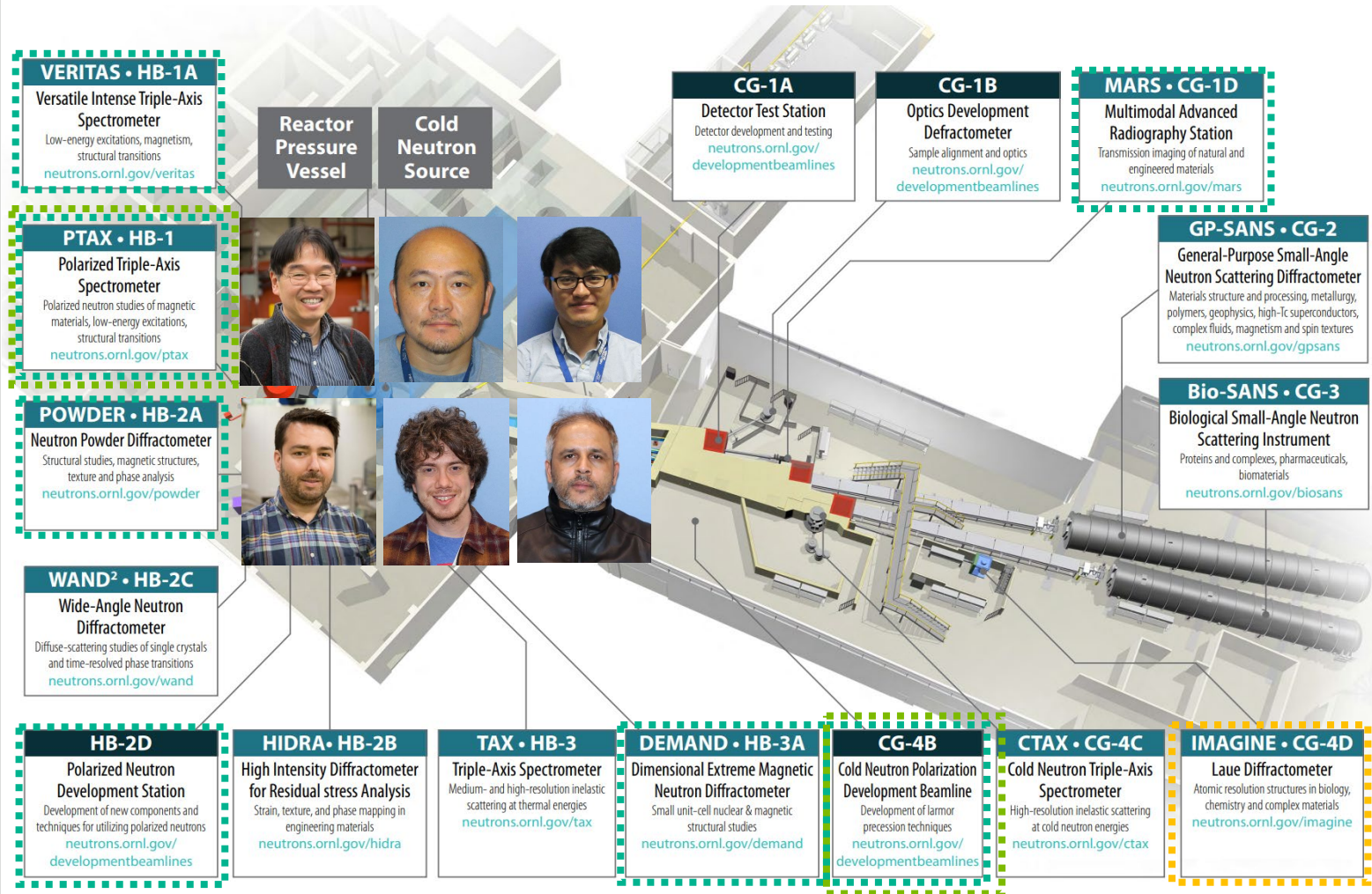

 Cold neutron user program
 Cold neutron beamline



High Flux Isotope Reactor is a facility of Oak Ridge National Laboratory, managed by UT-Battelle LLC for the US Department of Energy.

NIST

National Institute of Standards and Technology
U.S. Department of Commerce

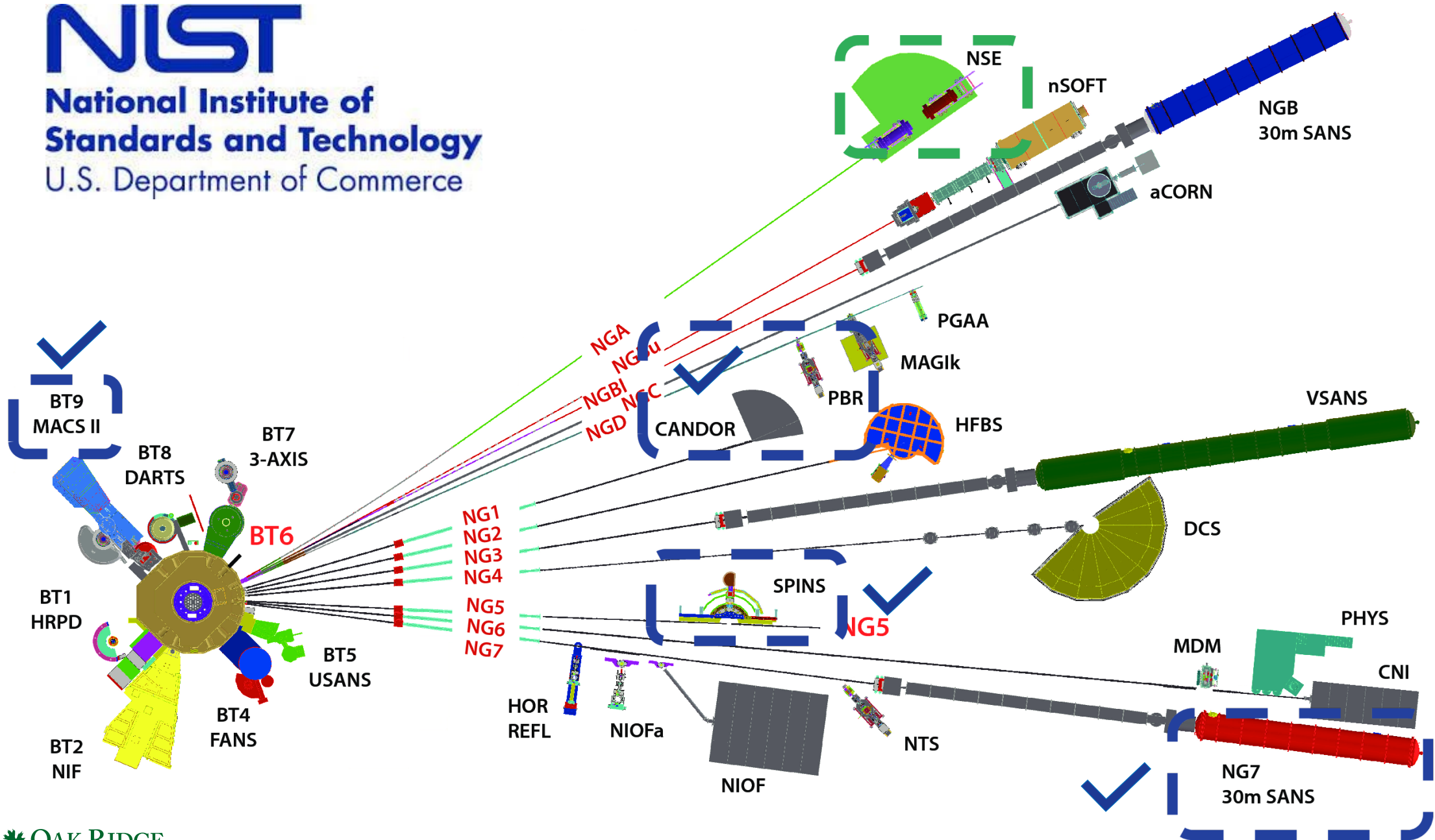

Software / workflow presentations & exercises

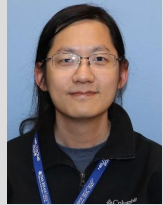

CrysPy



Spinvert, Spinteract



Magnetic PDF

Polarization Development presentations

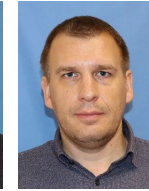

Mag2Pol



Welcome
Navid Qureshi!
(ILL)



From neutron scattering 101 to polarized neutron scattering

CHARACTER:

Neutrons sometimes behave as particles, and sometimes as waves

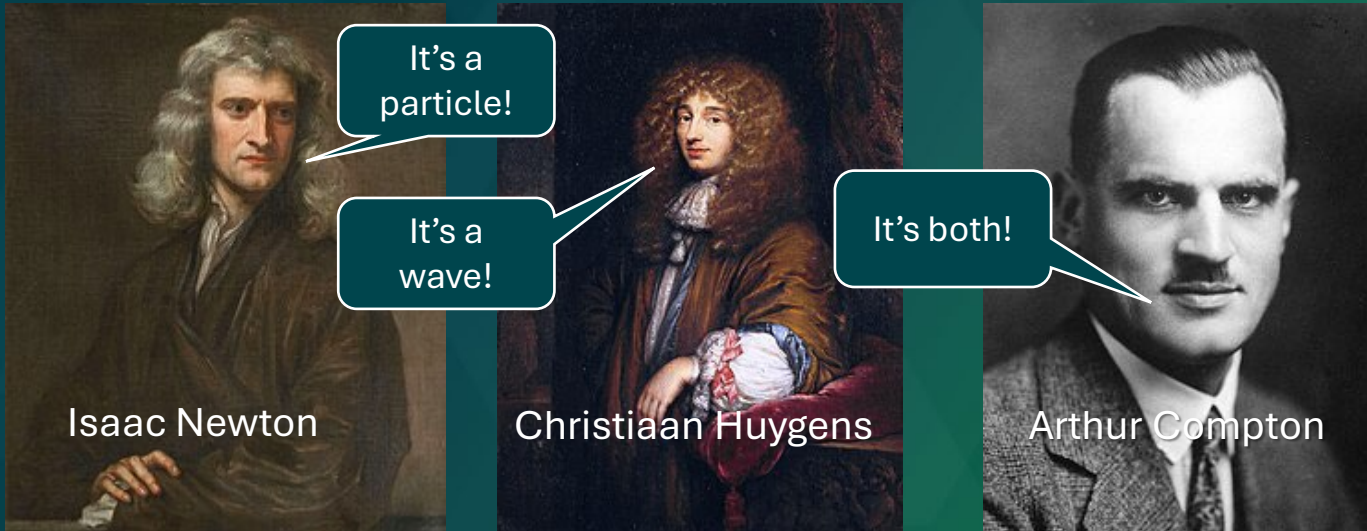

Confusion about Light

“Solved” with
**Quantum
Mechanics**



CHARACTER:

Neutrons sometimes behave as particles, and sometimes as waves, and sometimes they just get absorbed...

Scatter like a wave



“Coherent” scattering

“Feels” more of a volume all at once,
Scattering VERY direction dependent

Examples of coherent scattering:

Diffraction (feels adjacent scatter planes)

Phonons (feels collective wiggles)

Index of refraction (feels density)

Think ‘scattering length’

Scatter like a particle



“Incoherent” scattering

Single point of contact, scatters
in random directions

Loses ‘coherence’ via:

Random isotopes

Random nuclear spin orientations

Suppression of coherent scattering

Think ‘cross-sectional area’

Absorption



The nuclear reaction
you’re used to...

Prompt gammas, beta
rays, etc.

Most common
‘detector’ mechanism

CONTRAST: Neutrons scatter via 2 different forces, too

Nuclear Strong force



Interaction with nuclei of atoms
Depends on the *isotope*
Depends on *spin of the nuclei*
Depends on *nuclear resonances*

“Sees” lattice structure via nuclei location
“Sees” phonons & vibrational modes

Includes both scattering and **absorption**



(**absorption** is a nuclear reaction,
creating a new isotope
with an additional neutron)

Magnetic force



Interaction with the *magnetic field*
in a region about atoms

“Sees” magnetic structure
“Sees” magnetic excitations

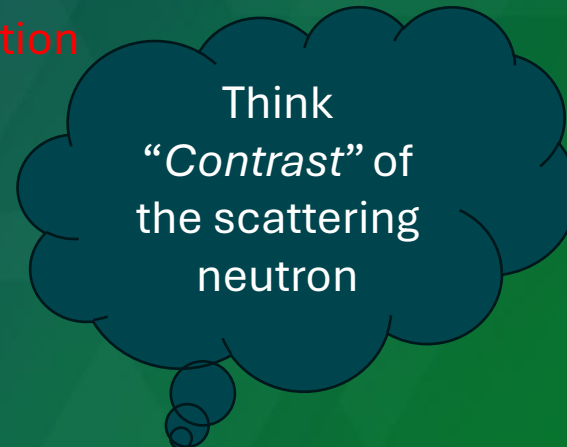

Think
“*Contrast*” of
the scattering
neutron

Combine Contrast & Character; or Particles, Waves & Forces

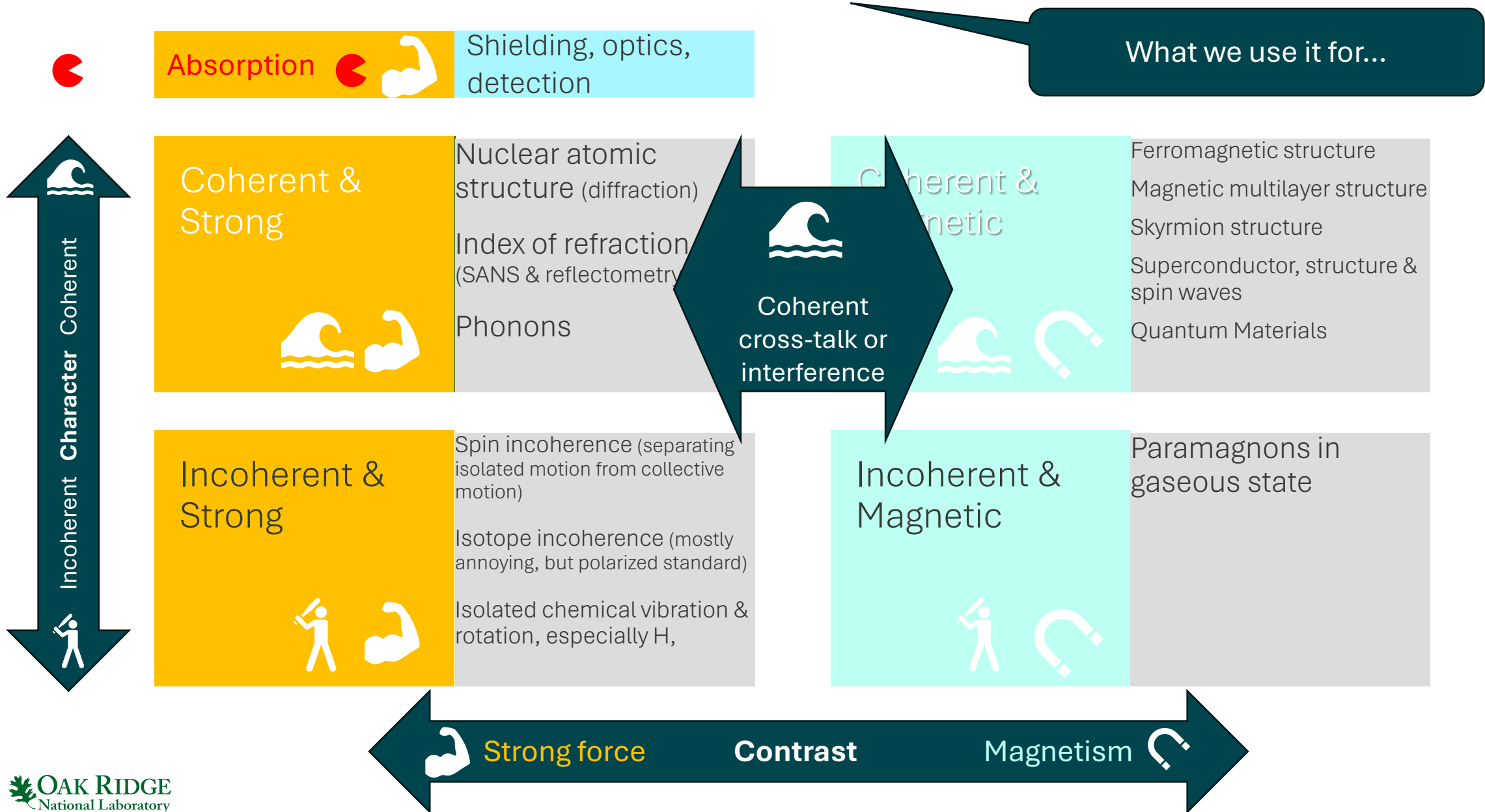

Specific neutron scattering instruments prioritize...

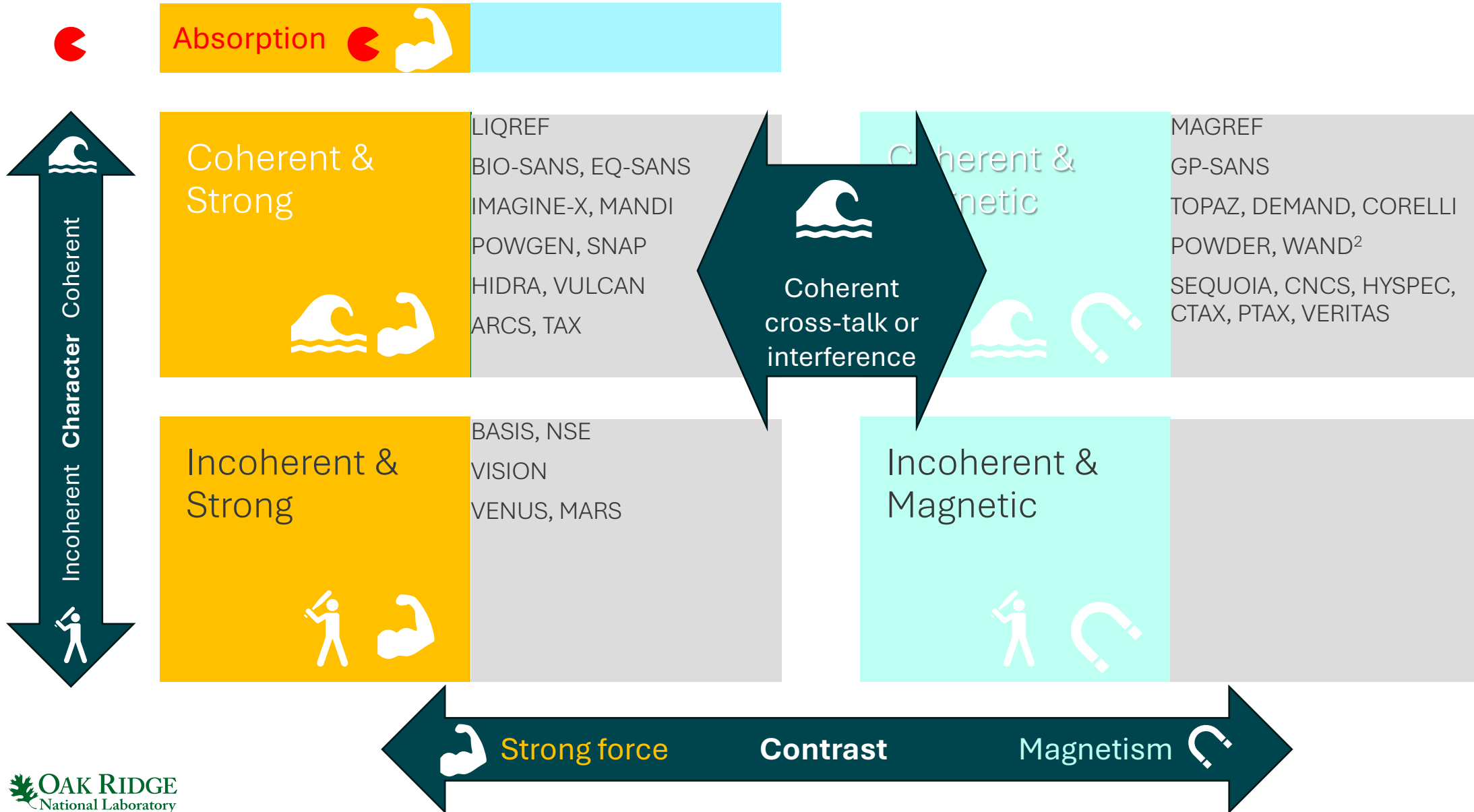

Different science thrusts roughly map

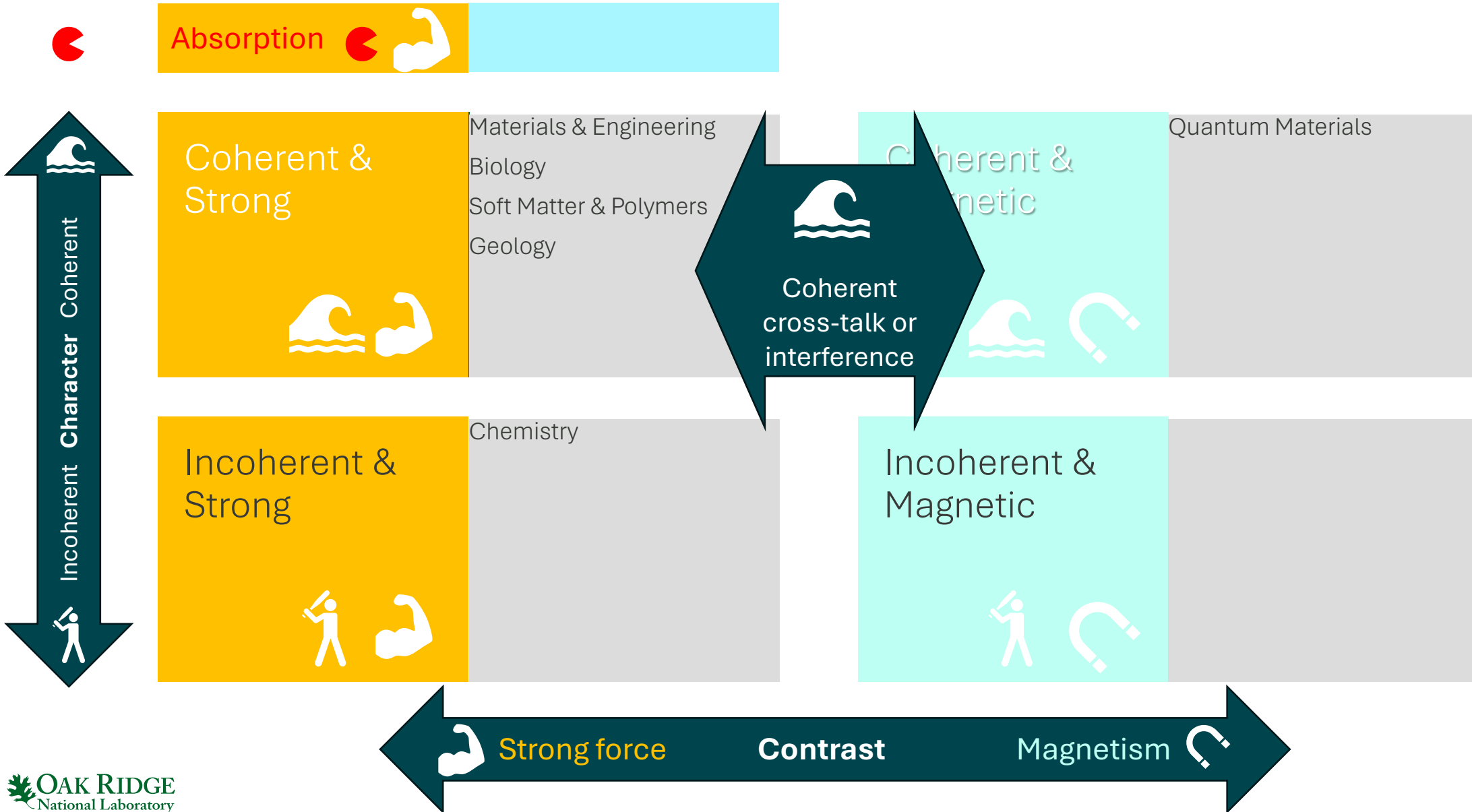

Early impact of magnetic coherent diffraction



- ✓ The first direct evidence of antiferromagnetism was produced in determining the magnetic structure of MnO - 1949

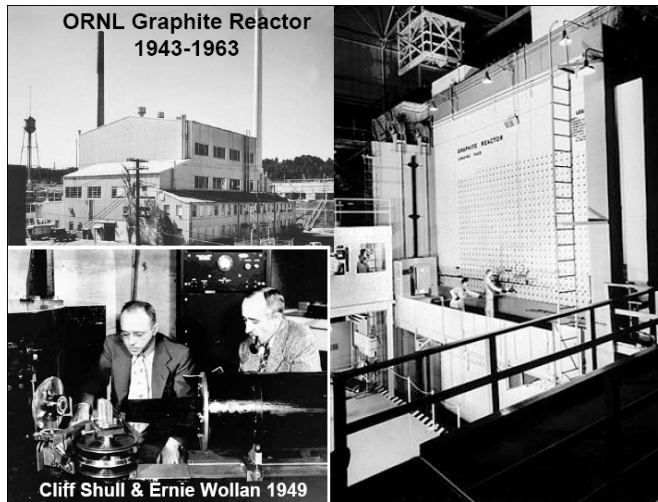

Detection of Antiferromagnetism by Neutron Diffraction*

C. G. SHULL
Oak Ridge National Laboratory, Oak Ridge, Tennessee

AND

J. SAMUEL SMART
Naval Ordnance Laboratory, White Oak, Silver Spring, Maryland

August 29, 1949

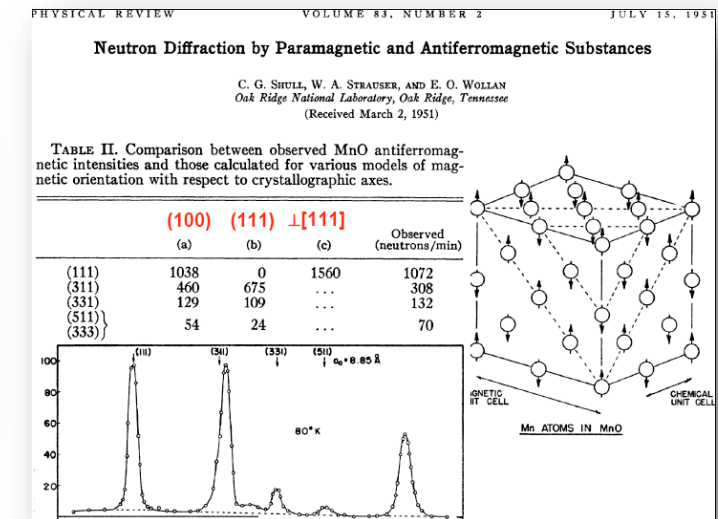

- ✓ the first magnetic form-factor data were obtained by measuring the paramagnetic scattering by Mn compounds (1951)
- ✓ the production of polarized neutrons by Bragg reflection from ferromagnets was demonstrated (1951)

$E=1/2 mv^2$ leads to useful matching of size to energy scales

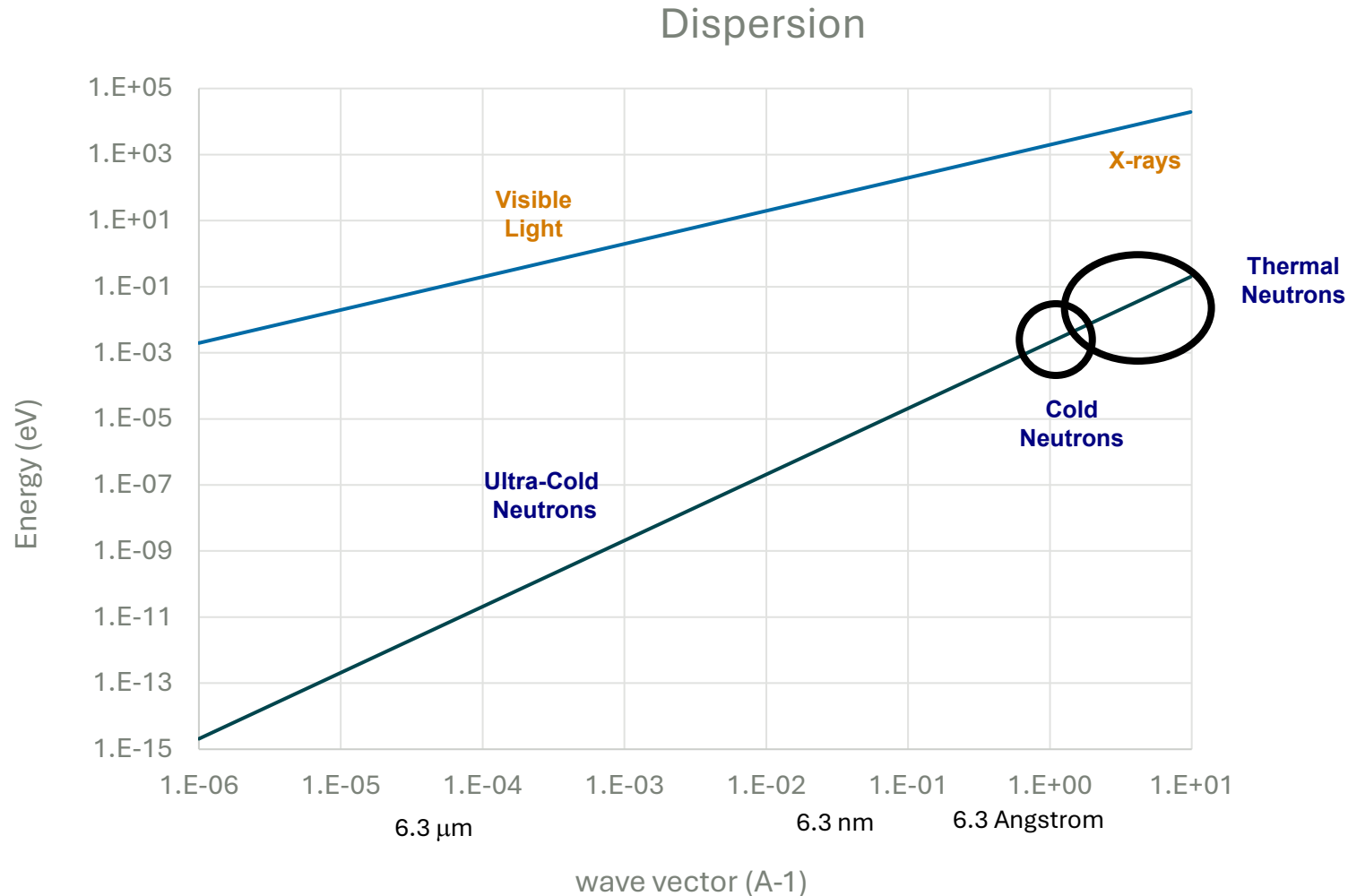

What do neutrons enable us to study in these materials?

Different measurements : Different techniques & probes : Different beamlines

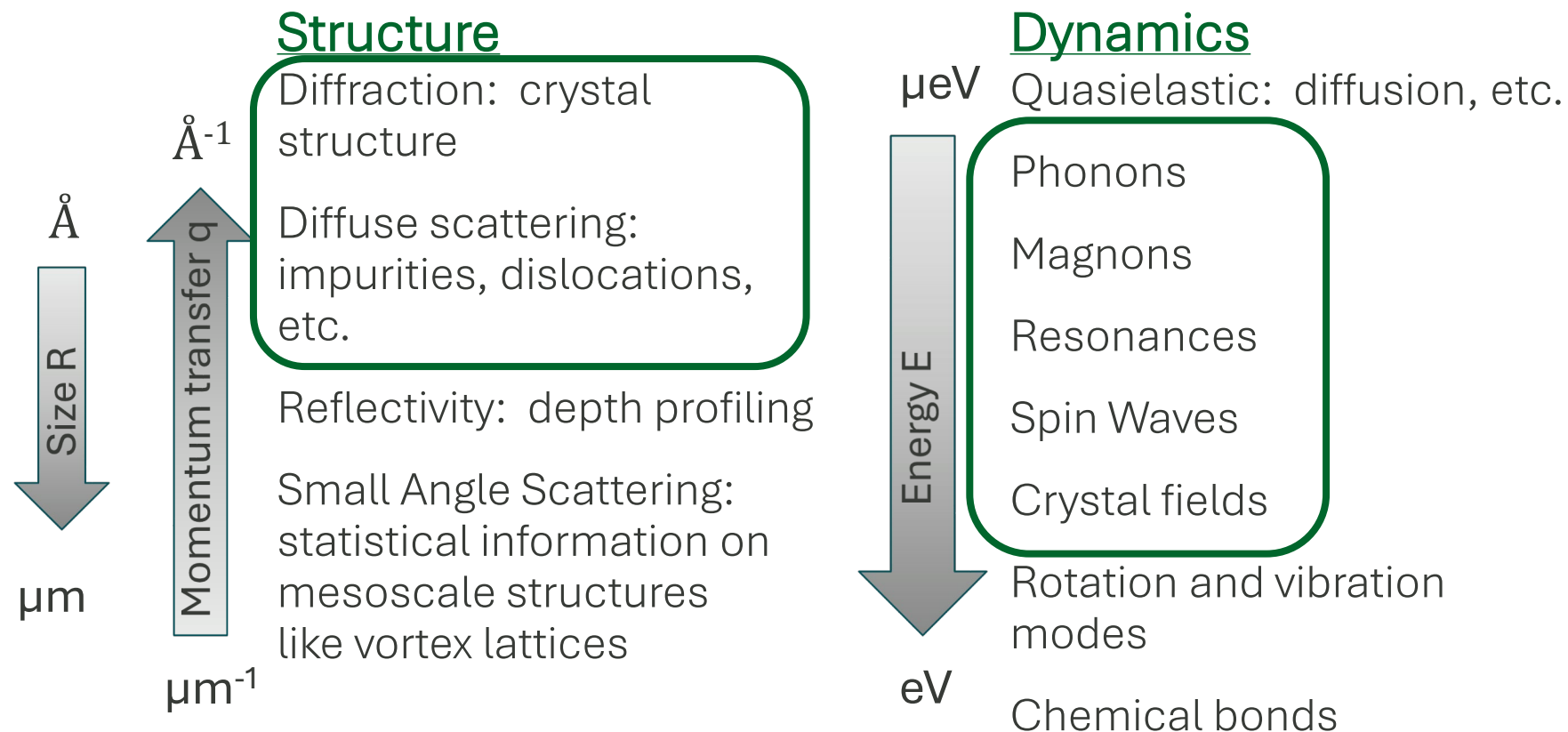

Momentum transfer direction during scattering \widehat{e}_Q defines what magnetism orientations will contribute to scattering contrast

Elastic $|k_i| = |k_f|$

(neutron) Energy loss
 $|k_i| > |k_f|$

(neutron) Energy gain
 $|k_i| < |k_f|$

Neutron vs excitation momentum (Q_s vs q)

Inelastic / spectroscopy convention

$$\vec{Q}_s = \vec{k}_i - \vec{k}_f$$

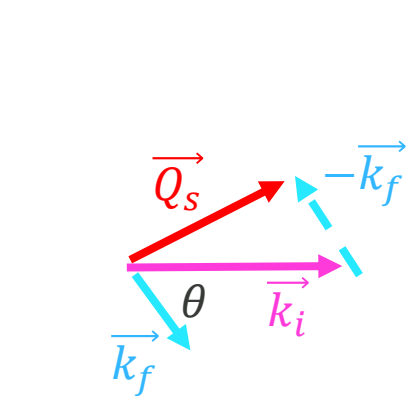
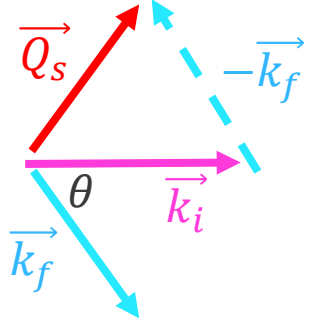

$$\vec{Q}_s = \vec{k}_i - \vec{k}_f$$

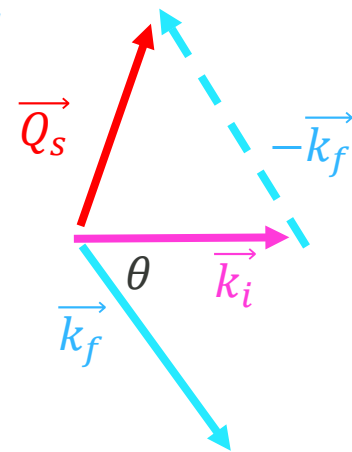

$$E = \frac{\hbar^2 k^2}{2m_n}$$

$$\omega = E_i - E_f > 0$$

$$\omega = E_i - E_f < 0$$

CREATES excitation in material

ANNIHILATES excitation in material

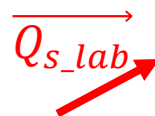

$$\vec{Q}_{s\text{sample}}(\phi)$$

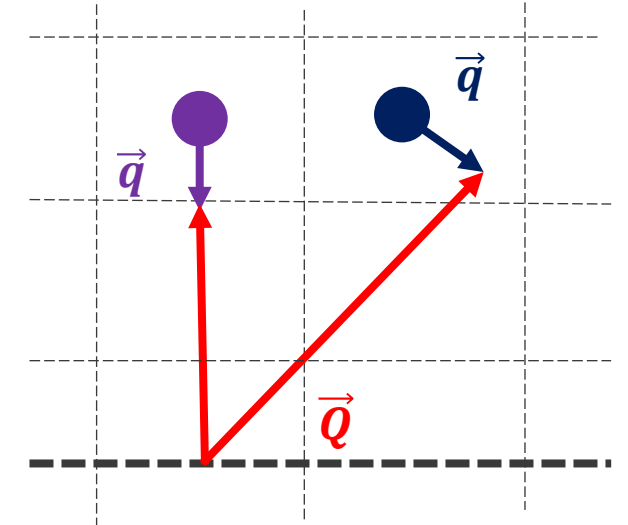

$$\widehat{e}_Q = Q/|Q|$$

Elastic / diffraction convention

$$\vec{Q}_e = \vec{k}_f - \vec{k}_i$$

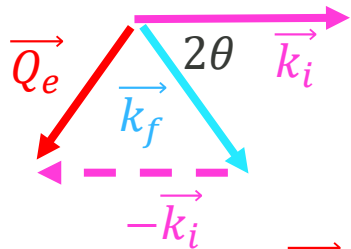

$$\vec{Q}_e = -\vec{Q}_s$$

CONTRAST: Vector-ing from the perspective of the 2 forces

Strong force



Spin:

$$\sigma_n = \frac{1}{2}$$

Quantum weirdness

Fermions don't like to share

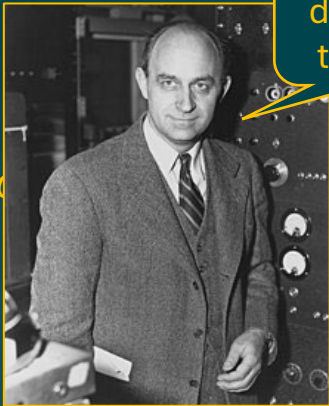

Enrico Fermi

Relative orientations of atomic nuclei

--- interacting with ---

--- leads to changes in ---

Scattered intensity

Magnetic force



Dipole moment:

$$\mu_n = -1.913 \mu_N$$

Nuclear magneton:

$$\mu_N = 5.051E - 27 \text{ JT}^{-1}$$

$$\mu_N = 3.15E - 5 \text{ meV/T}$$

Relative orientations of materials



Reorientation of the

spin or magnetic moment of the neutron, 3 charged quarks dancing inside each neutron

Changes in Scattered Neutron Intensity

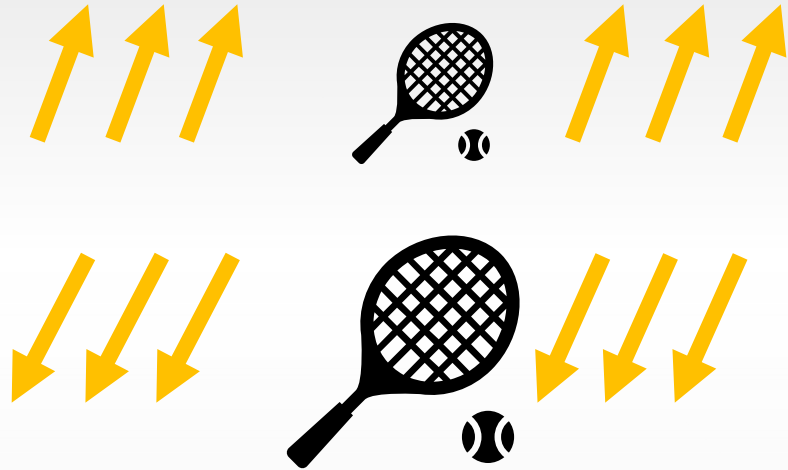

Changes in Neutron Orientation

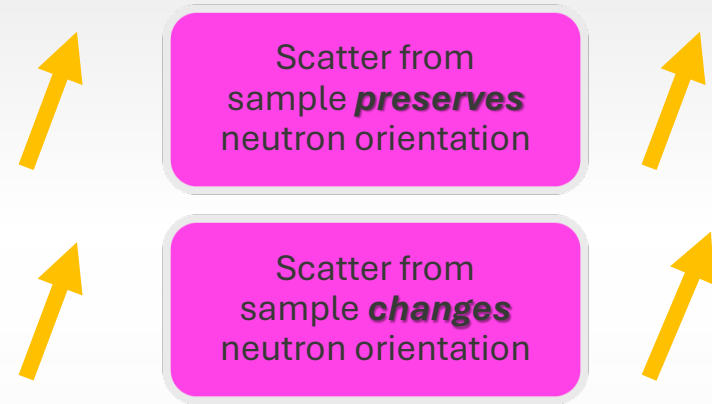

Yet, with unpolarized neutron scattering alone...

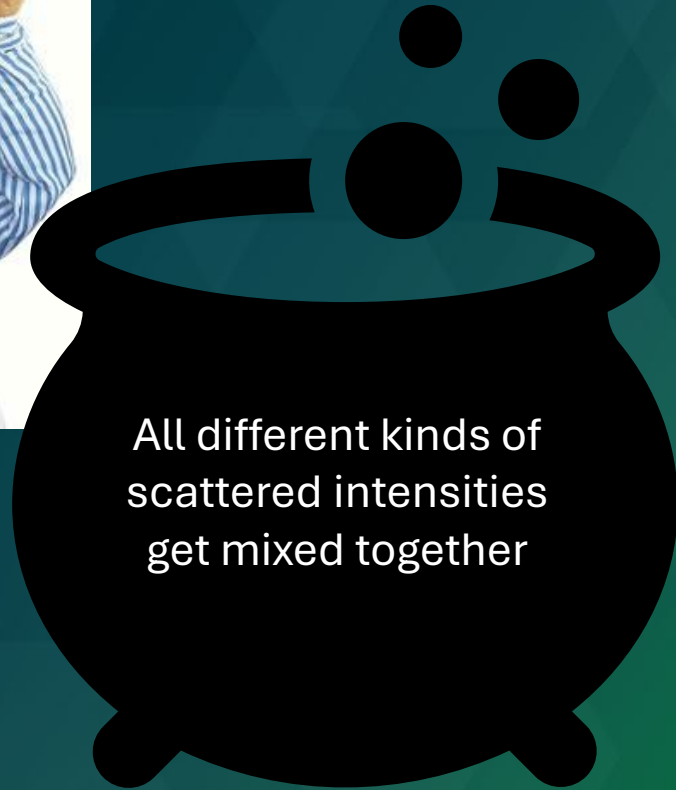

All different kinds of
scattered intensities
get mixed together

Scattered intensity



Cannot observe
neutron
reorientation

Reorientation of the
spin or magnetic moment
of the neutron

If only we had a way to filter and play with

the neutron **spin** or magnetic moment...



We could isolate different features



We could reveal different dimensions



We could answer new questions
(that we'll call 'CAPABILITIES')



But beware, 'polarization' has 4 meanings for neutron scattering



1



2

$$-1 \geq P_z \geq 1$$

3

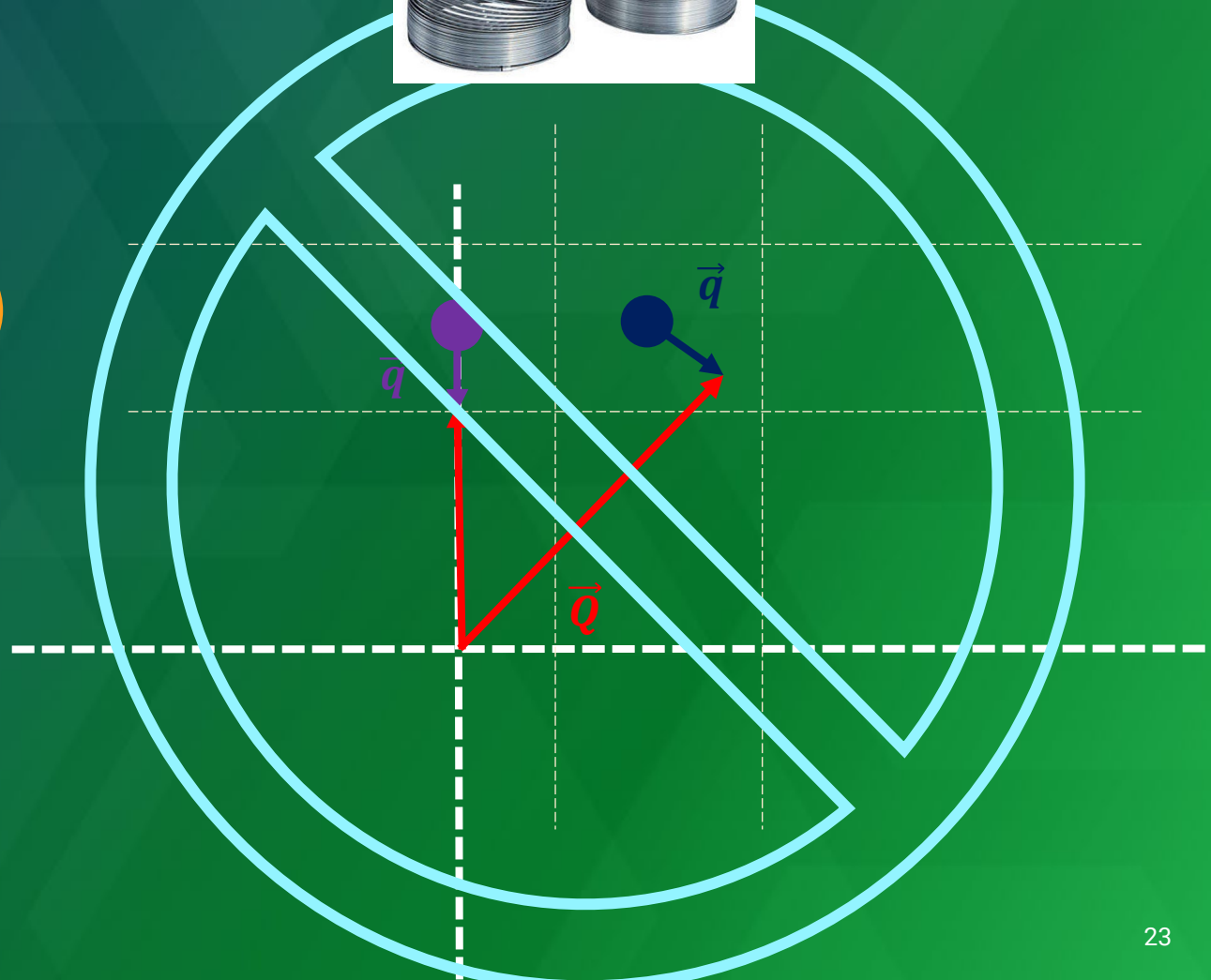

What? ANOTHER meaning for polarization?

4

This time, we're NOT referring to polarization of the neutron
INSTEAD, we're co-aligning either ATOMIC NUCLEI spins or
magnetic moments inside of some material

In this case, the MATERIAL is 'polarized' instead of the neutron!



Polarized materials can change scattered intensity of polarized neutrons

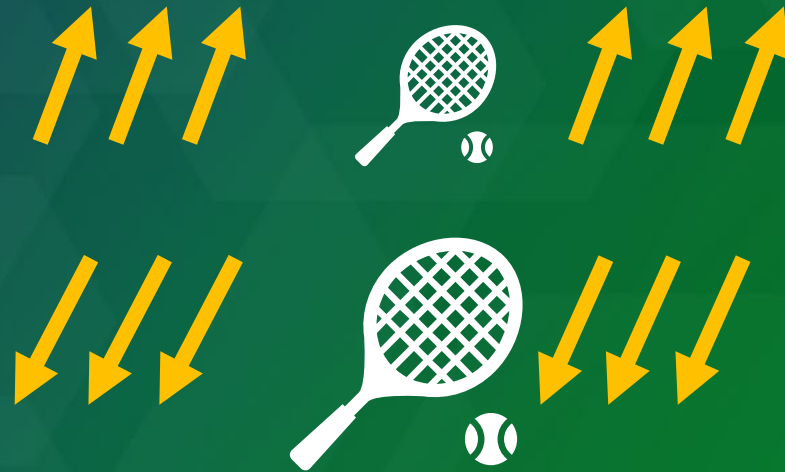

Ingredients for CONFIGURATIONS: Polarization Optics

Guide fields, Flippers, and Filters

Guide fields & Larmor precession



Ice skater



Break dancer

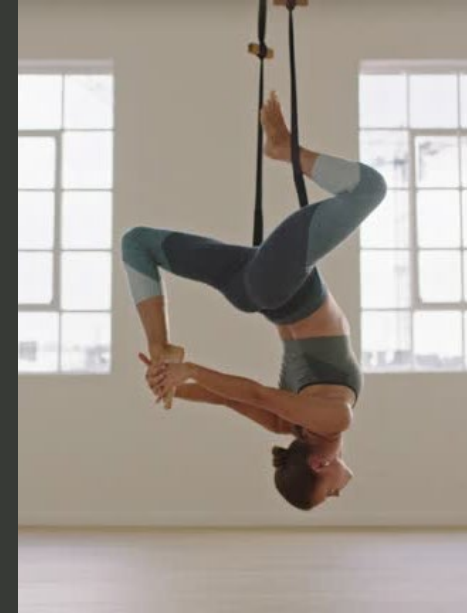

Rope dancer

Guide fields & Larmor precession

$$\vec{\omega} = k\vec{B}$$

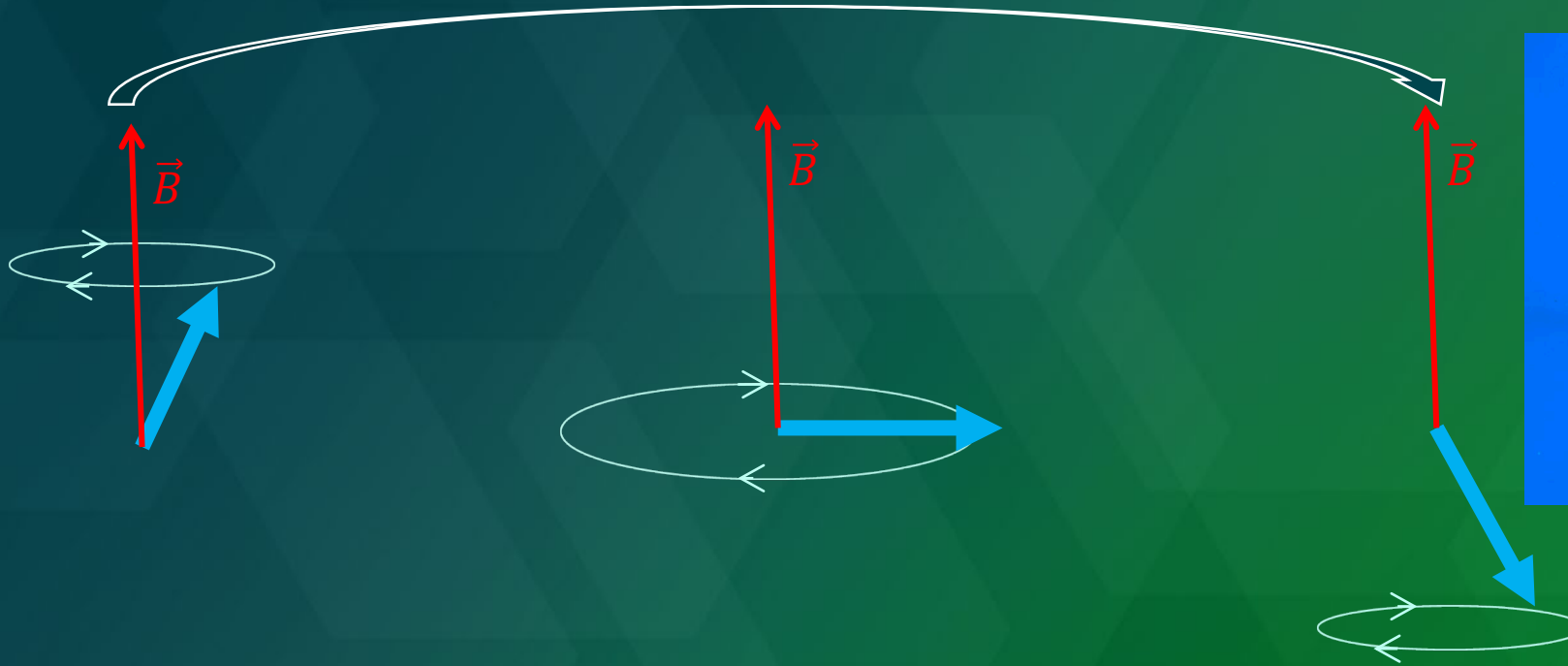

(mostly) parallel

$P \sim 1$

Right angle

$P \sim 0$

(mostly) antiparallel

$P \sim -1$

Guide fields as 'nutators'

Steering neutron moment while flying is possible

-IF- we precess fast enough to track the change in field direction

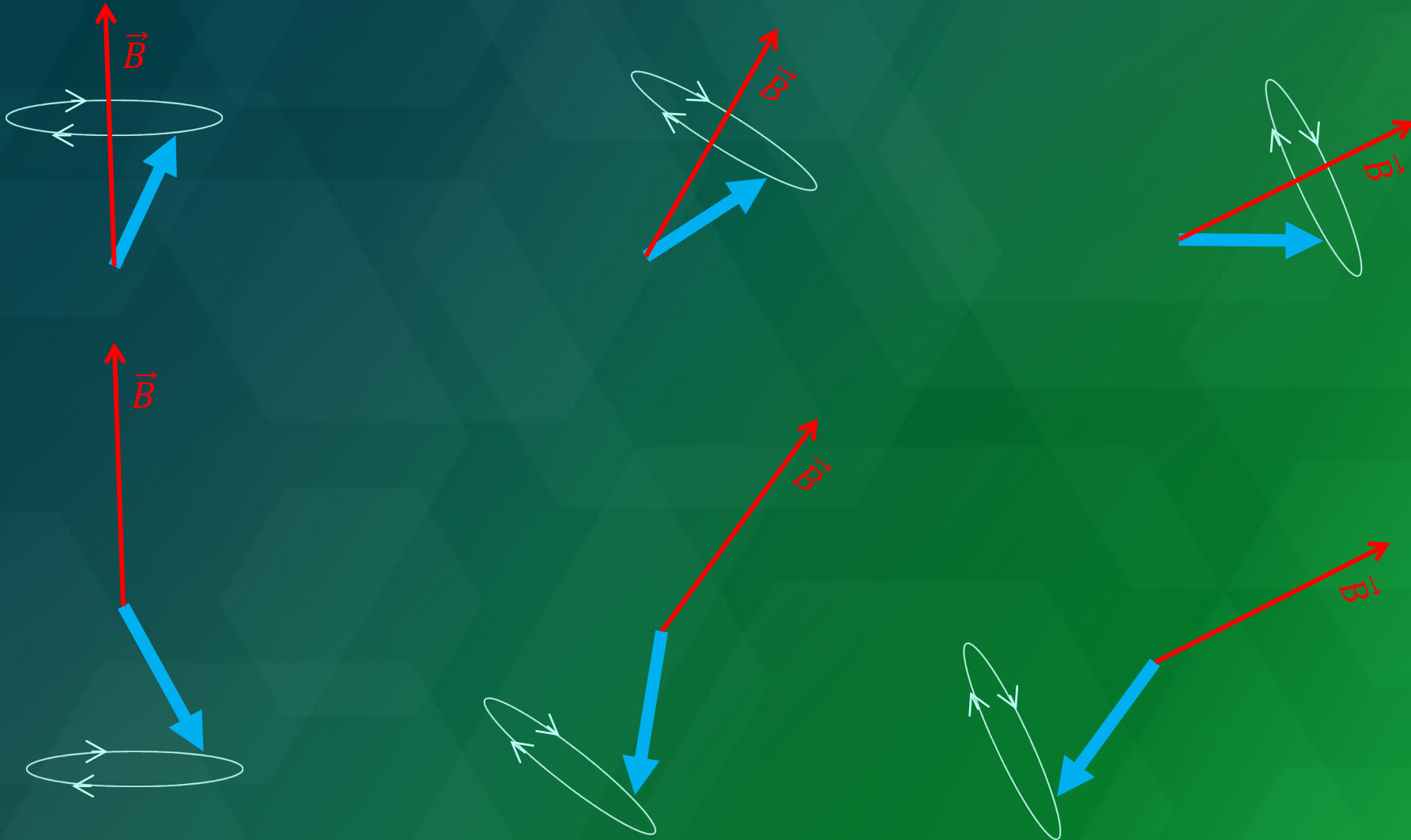

A Quantum perspective for Larmor Precession helps to figure how FILTERS work



Classical

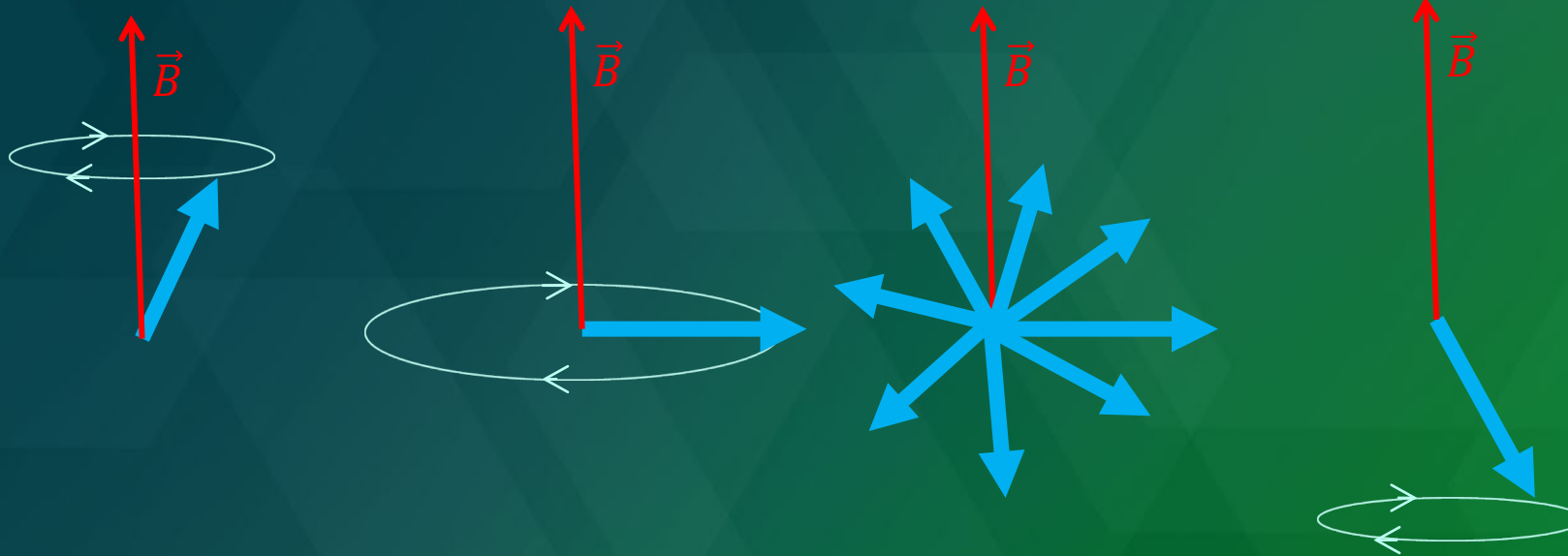

Quantum



So, if we could FILTER while the neutron is experiencing an external magnetic field, we could pass through up to half the neutrons!?!

2.1

Naming convention for filters:

‘**Polarizer**’ is the filter for the incident, pre-sample neutron beam

‘**Analyzer**’ is the filter for the scattered neutrons after the sample

Filters

- ‘Quantum’ has its advantages...
 - Unpolarized classical has arrows pointing everywhere
 - In ambient field, though, a quantum superposition of ‘up’ & ‘down’
 - A filter can achieve up to* 50% transmission

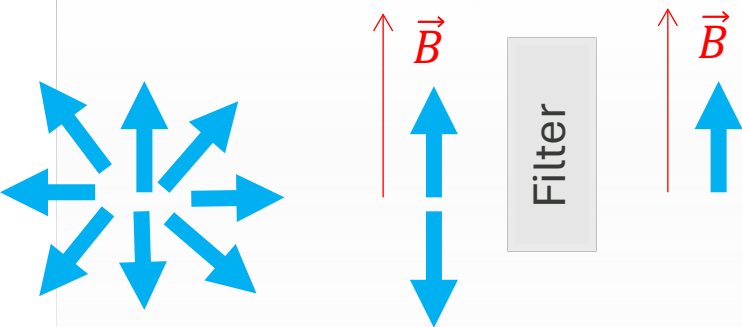

*Actual transmission varies widely...

Guide fields and nutators

- Larmor precession, via torque $\vec{\tau}$ on neutron magnetic moment $\vec{\mu}$ by applied magnetic field \vec{B}

$$\vec{\tau} = \vec{\mu} \times \vec{B}, \omega = -\gamma B$$

$$\gamma = -1.833\text{E}4 \text{ rad/Gauss-sec}$$

- Frequency ω is INDEPENDENT of polar angle φ between applied field and moment
- Magnetic ‘guide’ fields keep $\vec{\mu}$ either aligned or anti-aligned with respect to \vec{B}
 - Keeps ω fast while changing direction of \vec{B} slowly

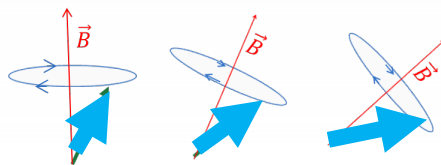

Flippers

Optionally invert the neutron spin-state with respect to the ambient guide field

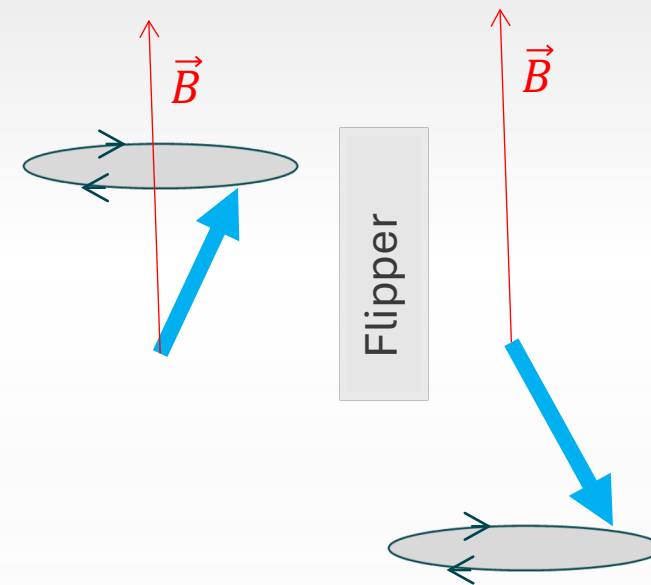

Filters



Heusler crystal



Polarizing Supermirror

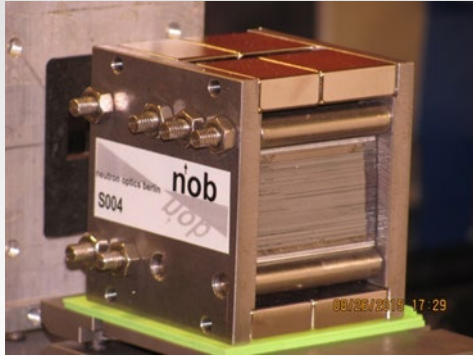

Nuclear-polarized ^3He

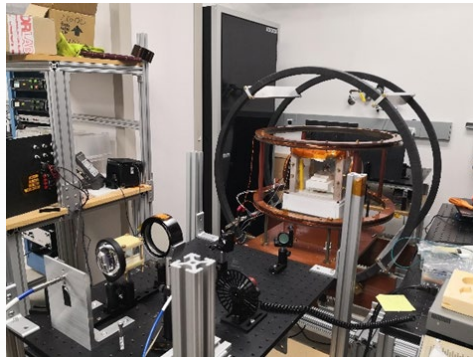

Guide fields and nutators

Permanent Magnet Yoked Assemblies

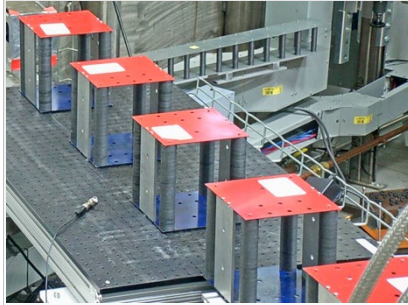

Rotatable nutator

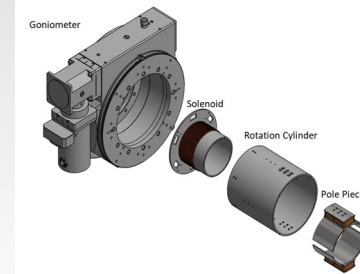

3D Coils

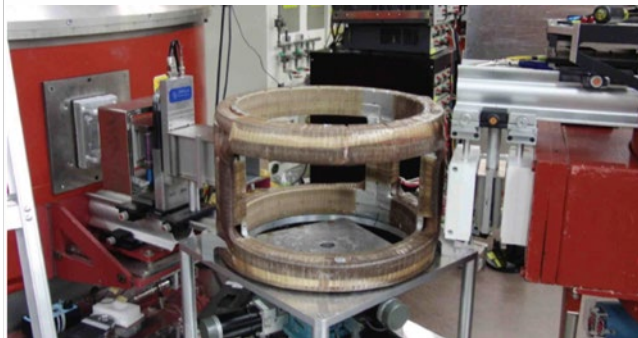

Flippers



Mezei

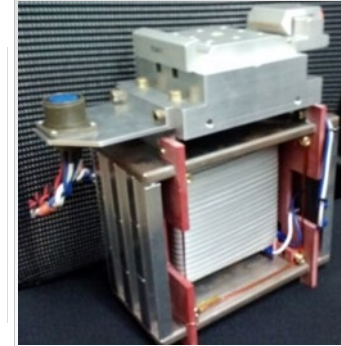

Radio-Frequency



Cryogenic
(Meissner screen)

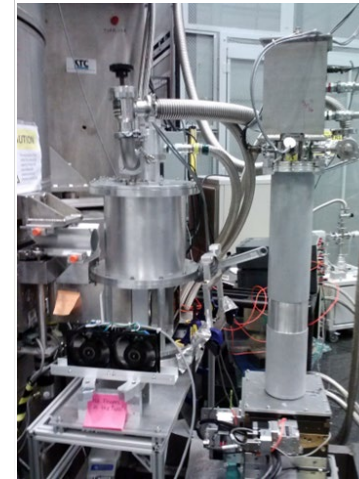

Adiabatic Fast
Passage /w ^3He



No system is perfect...

Polarization & Flipping Ratio

2

Polarization P

$$P = \frac{N^\uparrow - N^\downarrow}{N^\uparrow + N^\downarrow}$$

$$-1 < P < 1$$

Flipping ratio F

$$F = \frac{N^\uparrow}{N^\downarrow}$$

Due to imperfect

- Filters
- Guide fields
 - Modeling precession can help...
- Flippers
- Even *samples* can introduce depolarization effects

Transmission

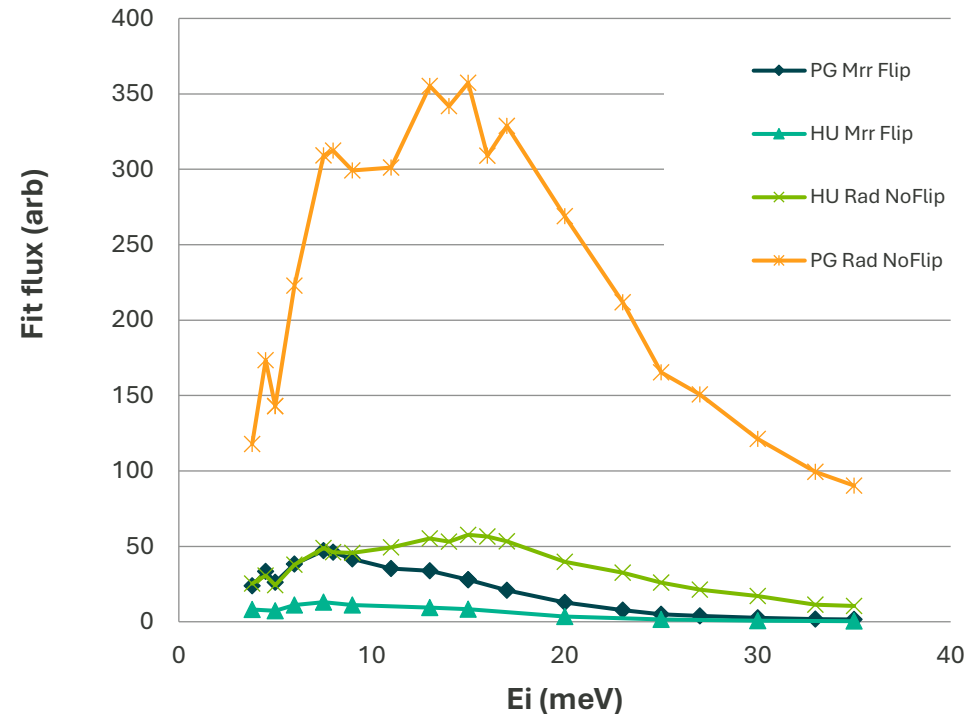

Scattering changes accessed by different CONFIGURATIONS



Ways to measure changes in scattered intensity and/or changes in neutron polarization orientation

Add changes to scattered intensity to the Contrast / Character Matrix

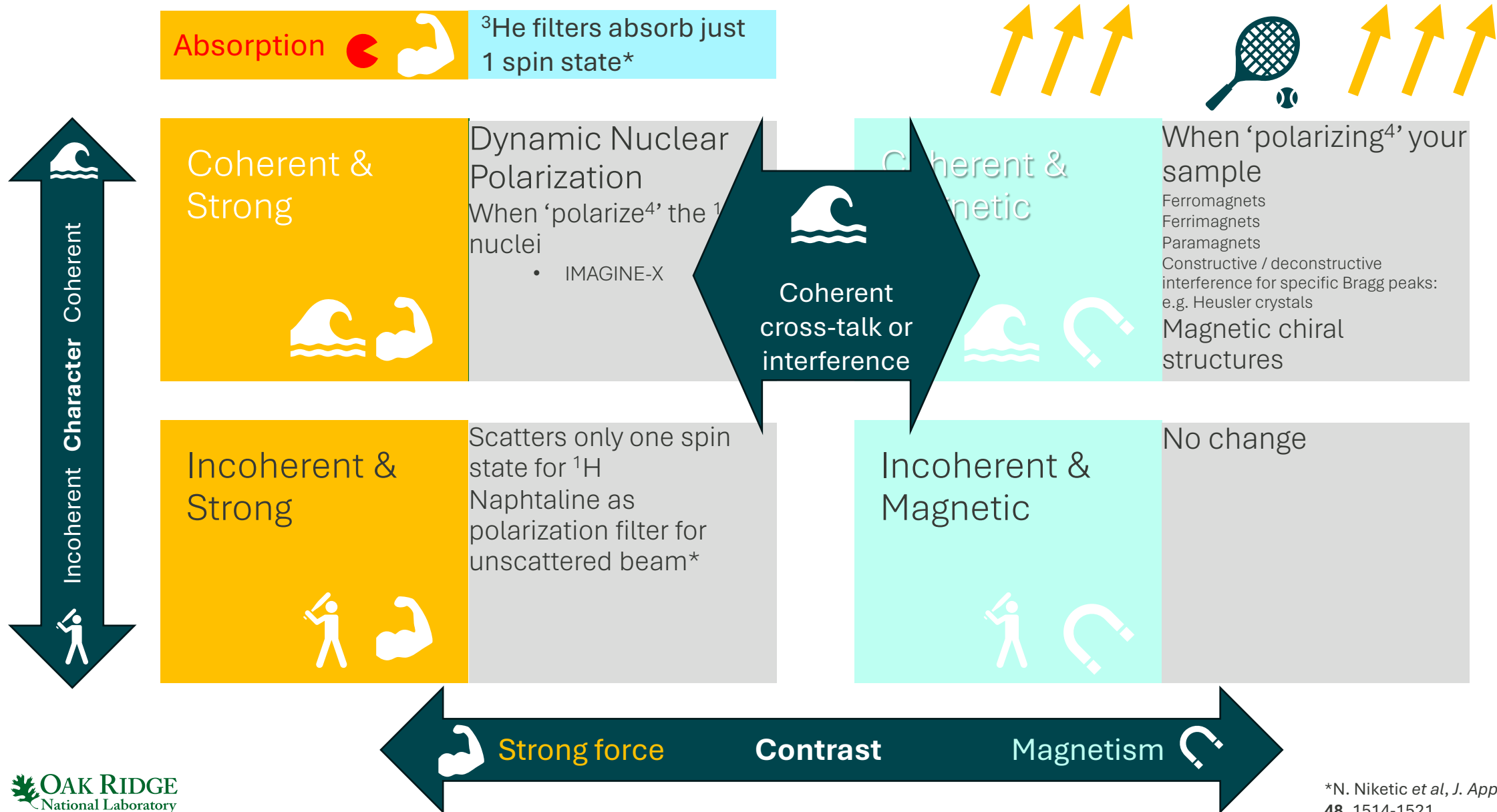

Add Vector Reorientation to the Contrast / Character Matrix

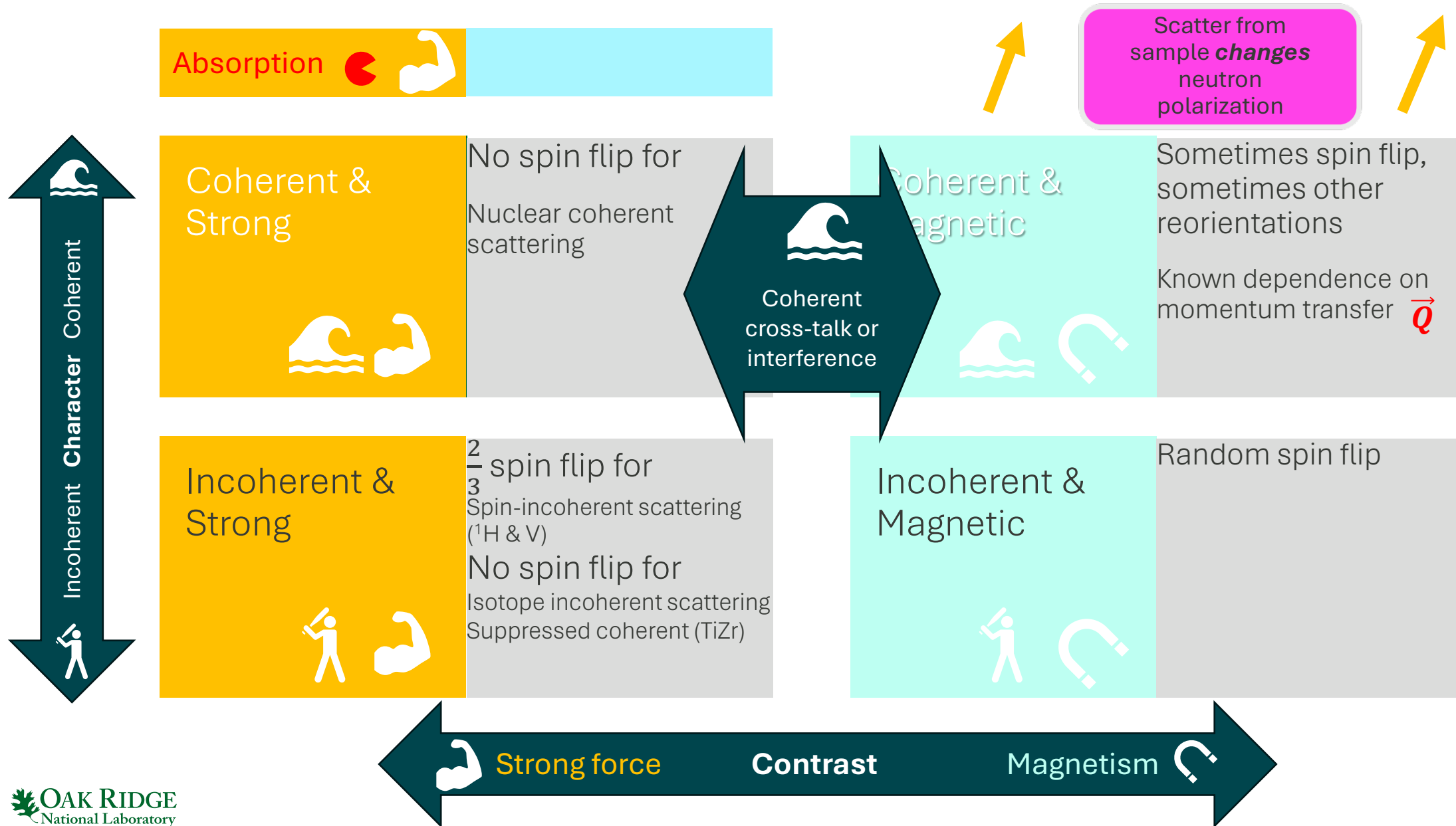

Formulas on next pages leverage lattice periodicity & coherent scattering

Coherence mechanism #1:
Leverage ***lattice periodicity*** for single crystals or powders
(think Bragg's law, Bloch equations, etc.)

Useful for ***diffraction*** and ***coherent inelastic scattering*** in comparable Q ranges

Leads to 'Maleev-Blume' equations with '***simple***' formulas relating various contributions to scattering ***into*** changes in neutron scattering intensity and/or polarization state

Will utilize Maleev-Blume vector equations as instructional aid for this introduction

Coherence mechanism #2:
Leverage ***# density variations*** leading into optical density variations

Useful for ***small angle neutron scattering (SANS)*** and ***reflectometry***

For e.g. 1D multilayer systems, NOT periodic so must ***directly solve Schrodinger's equation***

Similar approach to coherent interference effects
(here often called 'contrast matching')

Add changes to scattered intensity to the Contrast / Character Matrix

$$I = I_n + N^\dagger N + I_{si} + \vec{M}_\perp^\dagger \vec{M}_\perp + \vec{P} \cdot \vec{M}_\perp^\dagger N + \vec{P} \cdot \vec{M}_\perp N^\dagger + i\vec{P} \cdot (\vec{M}_\perp^\dagger \times \vec{M}_\perp)$$

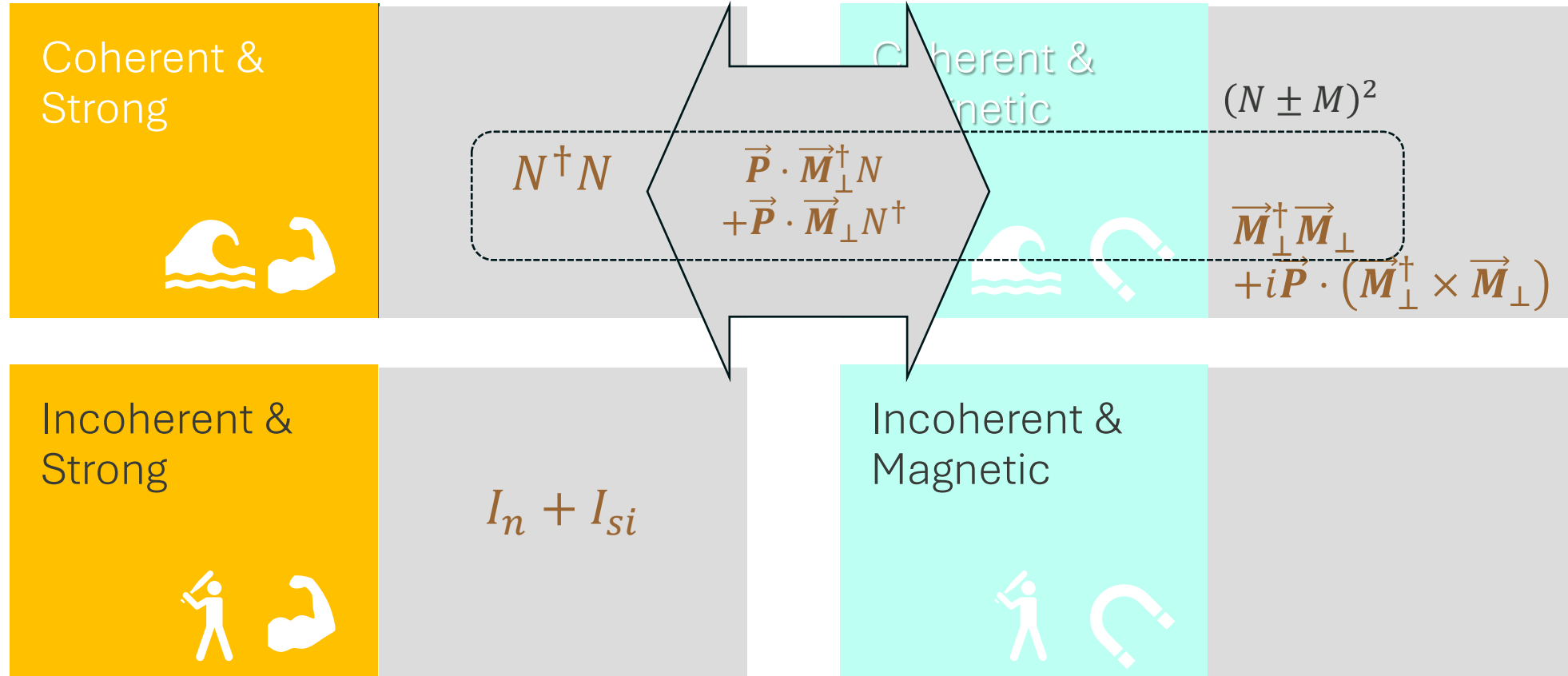

Add Vector Reorientation to the Contrast / Character Matrix by measuring filtered intensity

$$P^{\perp}I = P \left(I_n + N^{\dagger}N - \frac{1}{3}I_{si} \right) + (P \cdot M_{\perp}^{\dagger})M_{\perp} + (P \cdot M_{\perp})M_{\perp}^{\dagger} - P(M_{\perp}^{\dagger}M_{\perp}) + iN(P \times M_{\perp}^{\dagger}) - iN^{\dagger}(P \times M_{\perp}) + NM_{\perp}^{\dagger} + N^{\dagger}M_{\perp} - i(M_{\perp}^{\dagger} \times M_{\perp})$$

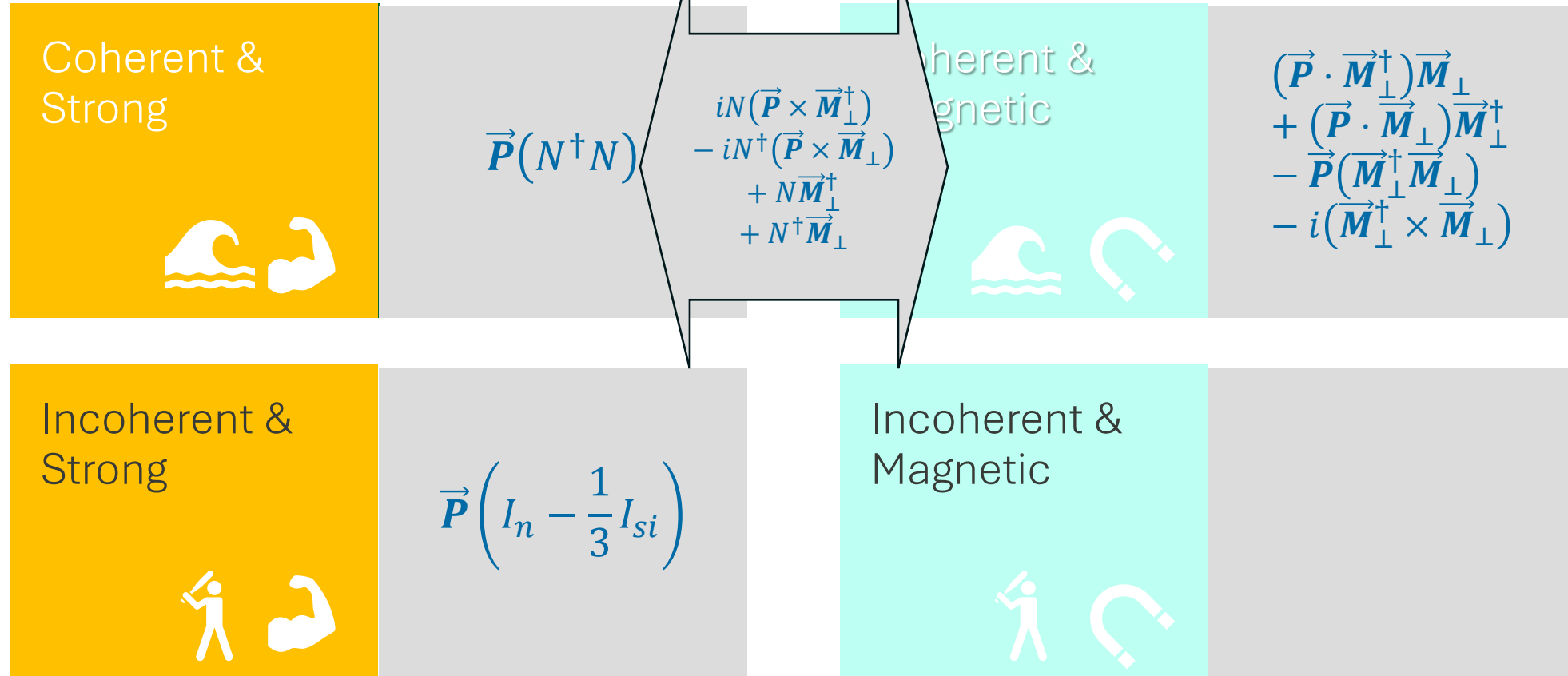

Qualitatively digging into vector reorientation just a bit more

$S_{ab}(\vec{Q}, \omega)$ Full Magnetic Structure Factor Tensor

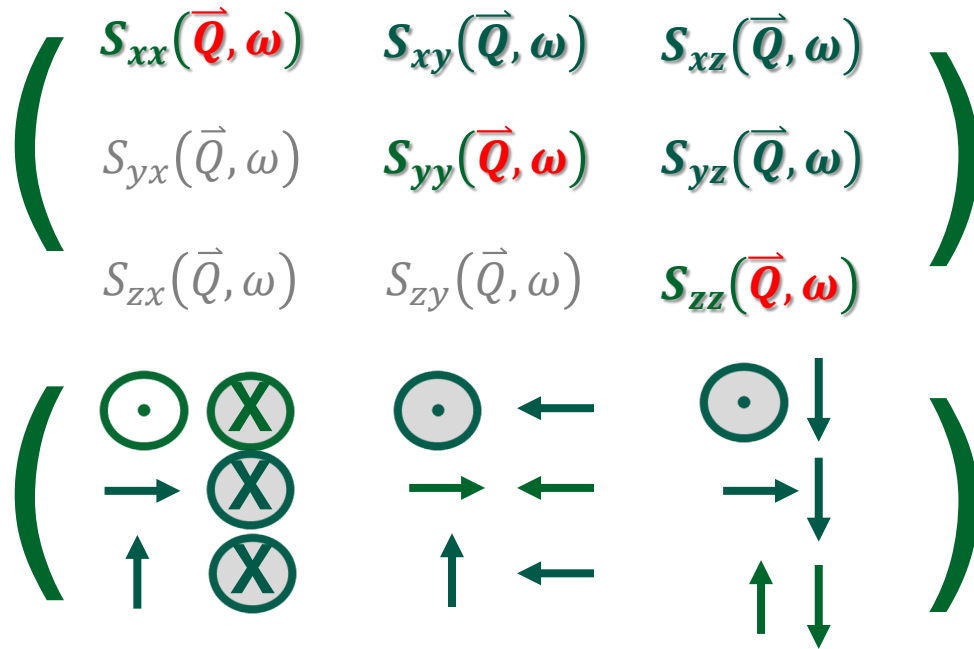

Diagonal elements
 Multiferroics
 Antiferromagnets
 Diffuse scattering

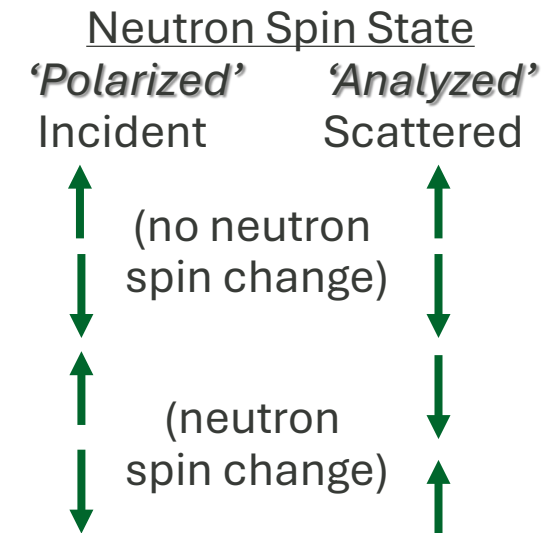

2.1

Off-Diagonal elements
needs 0 field at sample
 Beyond Spin-Flip
 Need for more exotic systems
 (chiral, spin-lattice coupling¹)

Meet the “Vector” family

\vec{R}_n		Coordinates of one atom in unit cell for crystal	
\vec{M}_n		Which way and how strong a magnetic moment of an <i>ATOM</i> points	
\vec{P}	Polarization	A measure of how ‘polarized’ the incident beam is, and average orientation of those neutrons’ spin (or magnetic moment) at sample position (definition #2)	Real space
\vec{P}'		The new polarization of the scattered neutrons	
\vec{Q}	Momentum transfer	Incident neutron momentum minus final neutron momentum $\vec{Q}_{lab} = \vec{k}_i - \vec{k}_f$	
$\vec{M}(\vec{Q})$	Magnetic structure factor*	Fourier transform of \vec{M}_n	Reciprocal space
\vec{M}_\perp	“M perp”	The component of the Magnetic structure factor perpendicular to the momentum transfer \vec{Q}	

Polarization CONFIGURATIONS access Intensity and/or *Polarization State*

$N(\mathbf{Q}) = \sum_n b_n e^{i\mathbf{Q}\cdot\mathbf{R}_n}$	Nuclear structure factor
$\mathbf{M}_\perp = \mathbf{e}_Q \times \mathbf{M}(\mathbf{Q}) \times \mathbf{e}_Q$	"M perpendicular"
$\mathbf{M}(\mathbf{Q}) = \sum_n \mathbf{M}_n e^{i\mathbf{Q}\cdot\mathbf{R}_n}$	Fourier transform of magnetic moments / magnetic structure factor
$\mathbf{e}_Q = \mathbf{Q}/ \mathbf{Q} $	Unit vector along momentum transfer \mathbf{Q}
I_{si}	Spin incoherent scattered intensity
$\mathbf{P}, \mathbf{P}^\dagger$	Initial and final polarization

POLARIZATION CONFIGURATION	Impacts the scattered neutron	Optics
Half Polarized Dynamic Nuclear Polarization Solve Phase Problem	Intensity	1 filter 1 flipper
Longitudinal Analysis (I) Larmor	Filtered intensity of specific polarization reorientations	2 filters 1 flipper
Longitudinal Analysis (II) Spherical Neutron Polarimetry	Both	2 filters 2 flippers

Changes in scattered intensity

$$I = I_n + N^\dagger N + I_{si} + \mathbf{M}_\perp^\dagger \mathbf{M}_\perp + \mathbf{P} \cdot \mathbf{M}_\perp^\dagger N + \mathbf{P} \cdot \mathbf{M}_\perp N^\dagger + i\mathbf{P} \cdot (\mathbf{M}_\perp^\dagger \times \mathbf{M}_\perp)$$

Changes in neutron orientation (filtered intensity)

$$\mathbf{P}^\dagger I = \mathbf{P} \left(I_n + N^\dagger N - \frac{1}{3} I_{si} \right) + (\mathbf{P} \cdot \mathbf{M}_\perp^\dagger) \mathbf{M}_\perp + (\mathbf{P} \cdot \mathbf{M}_\perp) \mathbf{M}_\perp^\dagger - \mathbf{P} (\mathbf{M}_\perp^\dagger \mathbf{M}_\perp) + iN (\mathbf{P} \times \mathbf{M}_\perp^\dagger) - iN^\dagger (\mathbf{P} \times \mathbf{M}_\perp) + N \mathbf{M}_\perp^\dagger + N^\dagger \mathbf{M}_\perp - i(\mathbf{M}_\perp^\dagger \times \mathbf{M}_\perp)$$

¹S. V. **Maleev**, V. G. Bar'yaktar, and R. A. Suris, The scattering of slow neutrons by complex magnetic structures Sov. Phys. Solid State 4, 2533 (1963)

²M. **Blume**, Polarization effects in the magnetic elastic scattering of slow neutrons, Phys. Rev. 130, 1670 (1963).

Tensor form of **vector reorientations**, Orthogonal orientations WRT **Q**, & single final direction

$$P_f = TP_i + P'$$

$$T\sigma = \begin{bmatrix} NN^* - \mathbf{M}_\perp \cdot \mathbf{M}_\perp^* & 2\text{Im}[NM_{\perp z}^*] & 2\text{Im}[NM_{\perp y}^*] \\ -2\text{Im}[NM_{\perp z}^*] & NN^* - \mathbf{M}_\perp \cdot \mathbf{M}_\perp^* + 2\text{Re}[M_{\perp y}M_{\perp y}^*] & 2\text{Re}[M_{\perp y}M_{\perp z}^*] \\ -2\text{Im}[NM_{\perp y}^*] & 2\text{Re}[M_{\perp z}M_{\perp y}^*] & NN^* - \mathbf{M}_\perp \cdot \mathbf{M}_\perp^* + 2\text{Re}[M_{\perp z}M_{\perp z}^*] \end{bmatrix}$$

$$P'\sigma = \begin{bmatrix} -2\text{Im}[M_{\perp y}M_{\perp z}^*] \\ 2\text{Re}[NM_{\perp y}^*] \\ 2\text{Re}[NM_{\perp z}^*] \end{bmatrix}$$

x along the direction of scattering vector **Q**, z perpendicular to the scattering plane, y completes the Cartesian set

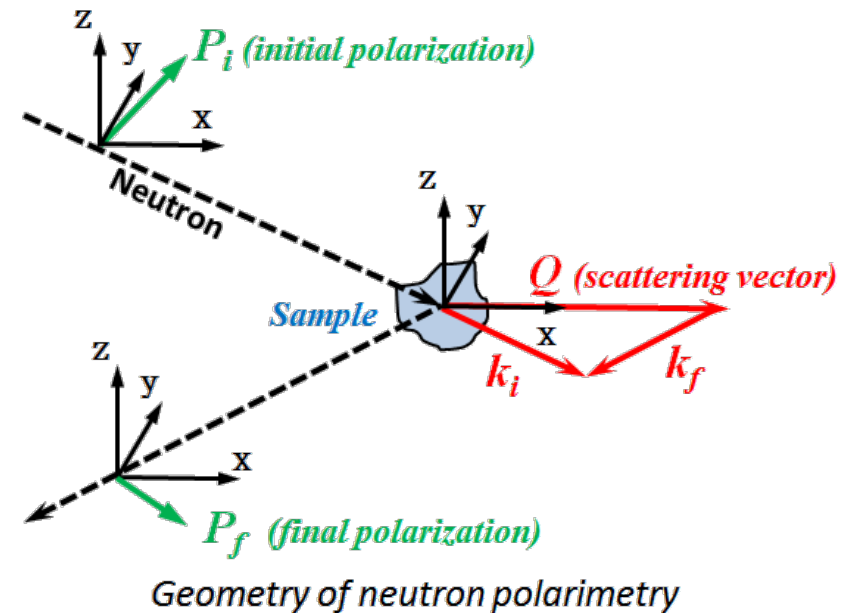

CONFIGURATIONS, what they access, and their optics

Changes in scattered intensity

$$I = N^\dagger N + I_{si} + \mathbf{M}_\perp^\dagger \mathbf{M}_\perp + \mathbf{P} \cdot \mathbf{M}_\perp^\dagger N + \mathbf{P} \cdot \mathbf{M}_\perp N^\dagger + i\mathbf{P} \cdot (\mathbf{M}_\perp^\dagger \times \mathbf{M}_\perp)$$

Changes in neutron orientation (filtered intensity)

$$P^1 I = P \left(N^\dagger N - \frac{1}{3} I_{si} \right) + (\mathbf{P} \cdot \mathbf{M}_\perp^\dagger) \mathbf{M}_\perp + (\mathbf{P} \cdot \mathbf{M}_\perp) \mathbf{M}_\perp^\dagger - P(\mathbf{M}_\perp^\dagger \mathbf{M}_\perp) + iN(\mathbf{P} \times \mathbf{M}_\perp^\dagger) - iN^\dagger(\mathbf{P} \times \mathbf{M}_\perp) + N \mathbf{M}_\perp^\dagger + N^\dagger \mathbf{M}_\perp - i(\mathbf{M}_\perp^\dagger \times \mathbf{M}_\perp)$$

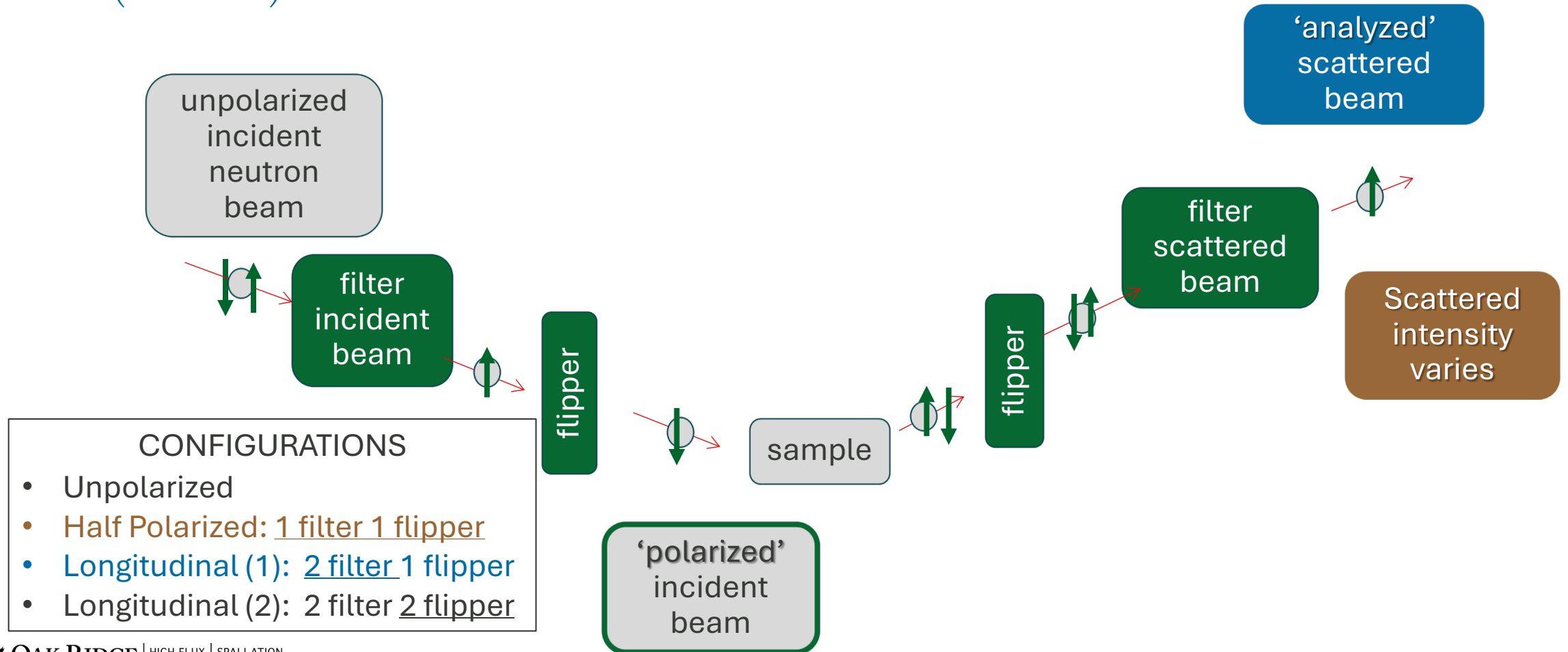

CAPABILITIES truncate those equations

Yes, the Maleev-Blume equations are VERY busy

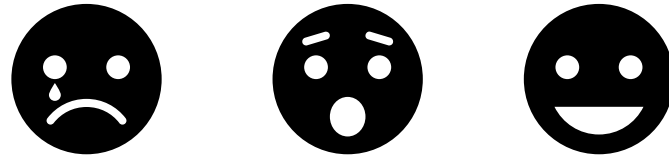

- Leverage *personality flaw* found in some scientists

- A. *Make assumptions* about the system you are studying
- B. Eliminate terms
- C. Simplify / Streamline the math

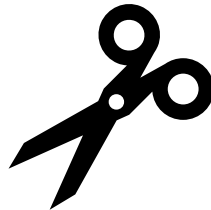

- Linear algebra

- N equations & N unknowns \rightarrow solvable problem



- Let's call the solutions to the streamlined equations "Capabilities"

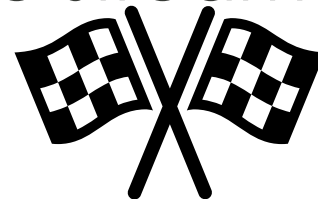

- Think word problems in reverse...

CONFIGURATIONS, CAPABILITIES and Capability Families

- “Configurations” are specific combinations of polarization optics enabling access to different Maleev-Blume equations
 - Will show examples of configurations in upcoming slides!
- “Capabilities” are specific solutions to streamlined Linear algebra problems
 - Can only be solved utilizing a subset of “Configurations”
 - Assume certain terms in Maleev-Blume equations aren’t present
 - Polarization-state ‘equation’ is actually several equations
- “Capability families” are intuitive (?) groupings of those specific solutions

Capability Families

Isolate nuclear scattering	$N \& I_N$
Isolate spin-incoherent scattering	I_{si}
Leverage dynamic nuclear polarization	$N \leftrightarrow I_{si}$
Solve Phase Problem	$N \& M_{\perp}$
Explore magnetic scattering	M_{\perp}
Explore coinciding of nuclear and magnetic scattering	N with M_{\perp}
Explore magnetic chirality	M_{\perp} cross terms

Color Key

Nuclear Scattering (coherent & isotope-incoherent)
Spin-Incoherent Scattering
Magnetic Scattering
Dynamic Nuclear Polarization
Other

Ingredients for your 'polarized' application statement

As a [**SCIENCE AREA**] neutron scattering experimentalist, I want to
 [**NEUTRON SCATTERING TECHNIQUE**]
so I can [**APPLICATION statement**] for [**SCIENCE EXAMPLE**]

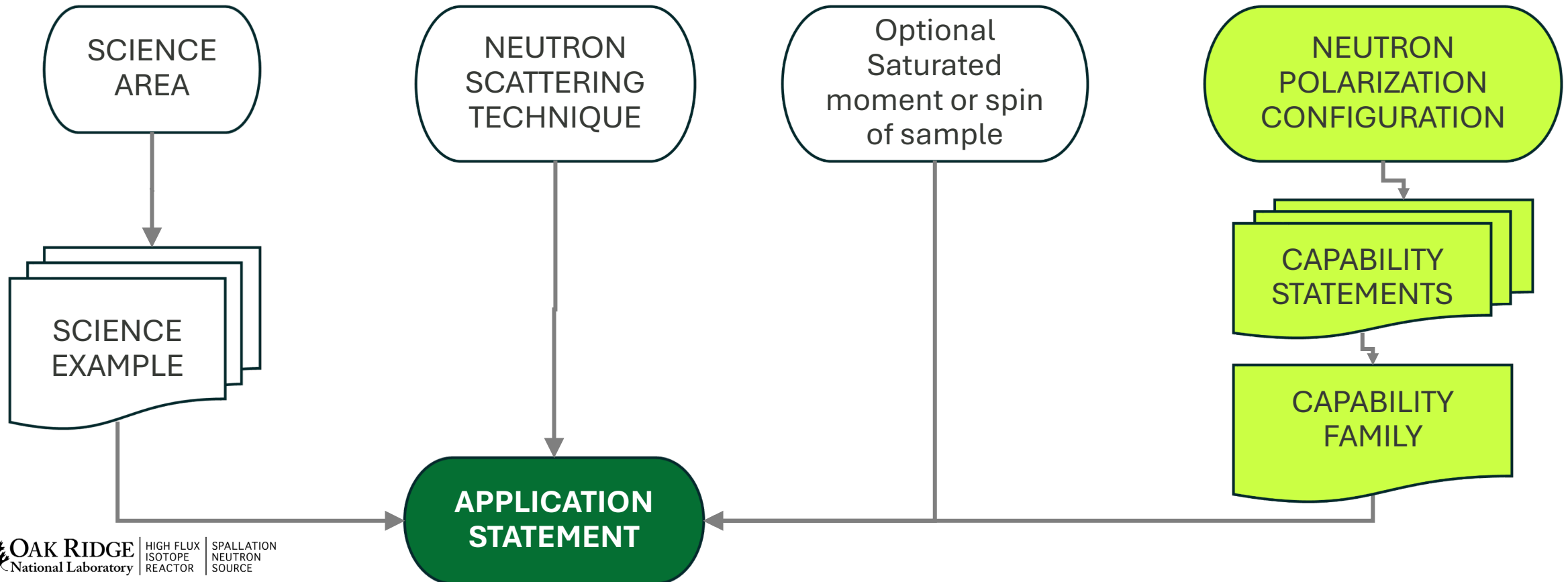

Mapping from your science area into demonstrated capability families, then into Configurations

Science areas						Capability Families		Configurations				
Biological	Soft Matter & Polymers	Materials & Engineering	Condensed matter & Quantum materials	Chemistry	Geology	Environmental Science		Half Polarized	Logitudinal Polarized 1	Logitudinal Polarized 2	Spherical Neutron Polarimetry	Larmor
							Isolate nuclear scattering					
							Isolate spin-incoherent scattering					
							Leverage dynamic nuclear polarization	+				
							Solve Phase Problem	+				
							Explore magnetic scattering					
							Explore coinciding of nuclear and magnetic scattering			+		
							Explore magnetic chirality			+		

‘+’ refers to the need for a little something extra

Dynamic Nuclear Polarization *also requires* co-aligning spins of atomic nuclei

Solving the Phase Problem for reflectometry *also requires* a substrate whose magnetization can be reoriented

Spherical Neutron Polarimetry *also requires* a zero-field chamber about the sample and additional spin manipulation optics

Can I even use the needed polarization capability at the desired instrument?

POLARIZATION CONFIGURATION	# Filters	# 'Flippers'	# incident neutron orientations / 2	# Measurements	Impacts the scattered neutron	POWDER	DEMAND	PTAX	HYSPEC	MAGREF	NSE
Half Polarized, high vert. H	1	1	1	2	Intensity	Green	Green	Green	Green	Green	
Half polarized, high horiz. H	1	1	1	2	Intensity			Yellow	Yellow	Yellow	
Longitudinal Analysis I, vertical	2	1	1	2	Polarization State			Green	Green	Green	
3D Longitudinal Analysis I			3	6		Green	Green	Green			
Long 1, vertical and 'x'			2	4		Green	Green	Green			
Long 1, wide h+v angle, account I_si			5	10				Red			
Longitudinal Analysis II	2	2	1	4	Both			Yellow		Green	
Spherical Neutron Polarimetry	2	2	6	24	Both			Yellow	Orange		
Larmor	2	2	many		Polarization State			Green			Green

Configuration drill-down

With slight detours to better understand neutron polarization components

This introductory lecture is broader than the workshop focus. You can skip or 'leapfrog' some topics



“Half Polarized” Configuration: 1 filter, 1 flipper

$$I = N^\dagger N + I_{si} + M_\perp^\dagger M_\perp + P \cdot M_\perp^\dagger N + P \cdot M_\perp N^\dagger + iP \cdot (M_\perp^\dagger \times M_\perp)$$

2 measurements
Doesn't care about
neutron spin
reorientation

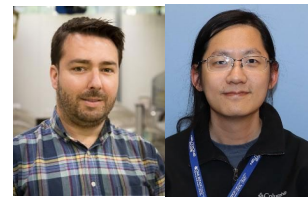
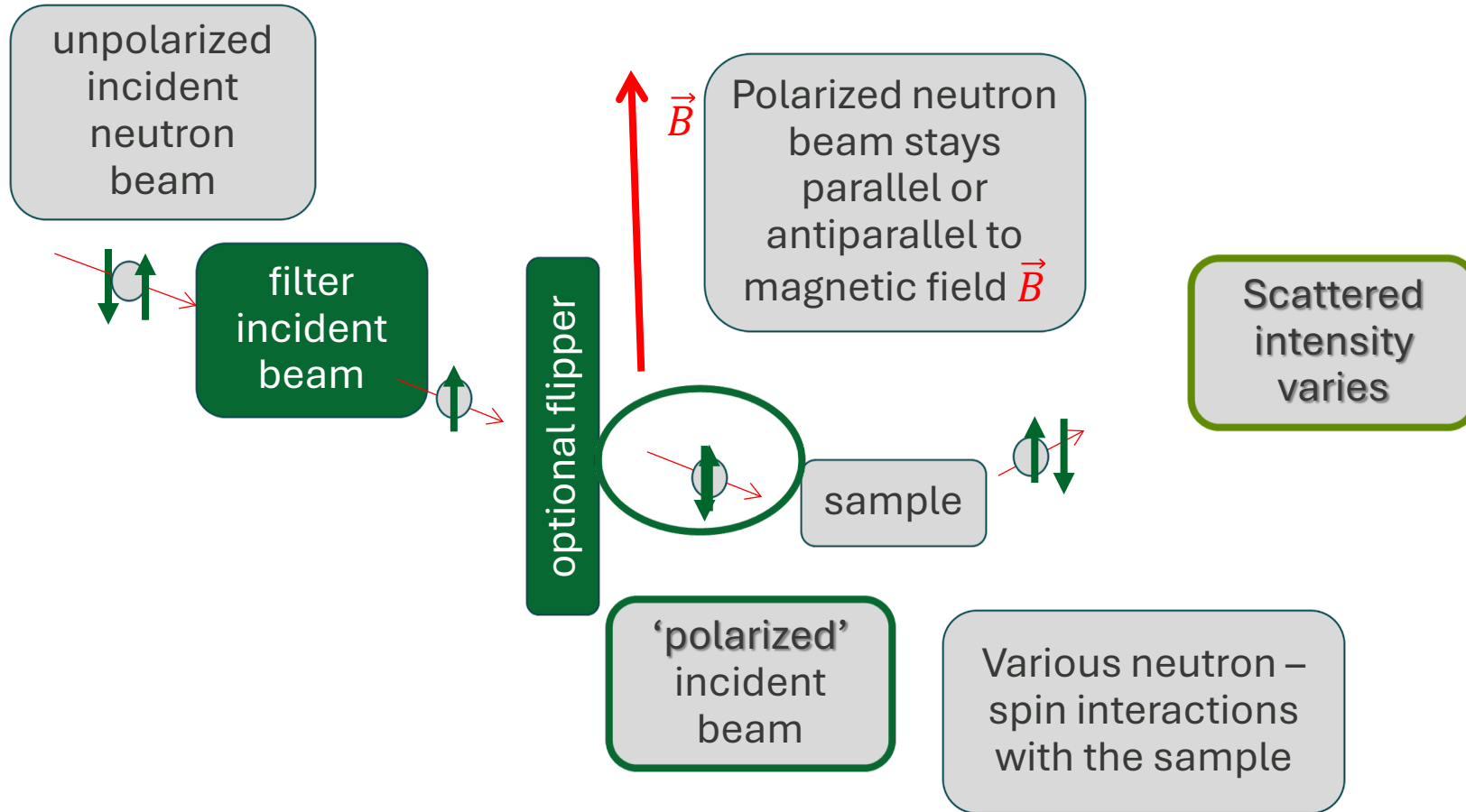

Equivalent “Half Polarized” Configuration for MAGREF

$$I = N^\dagger N + I_{si} + M_\perp^\dagger M_\perp + P \cdot M_\perp^\dagger N + P \cdot M_\perp N^\dagger + iP \cdot (M_\perp^\dagger \times M_\perp)$$

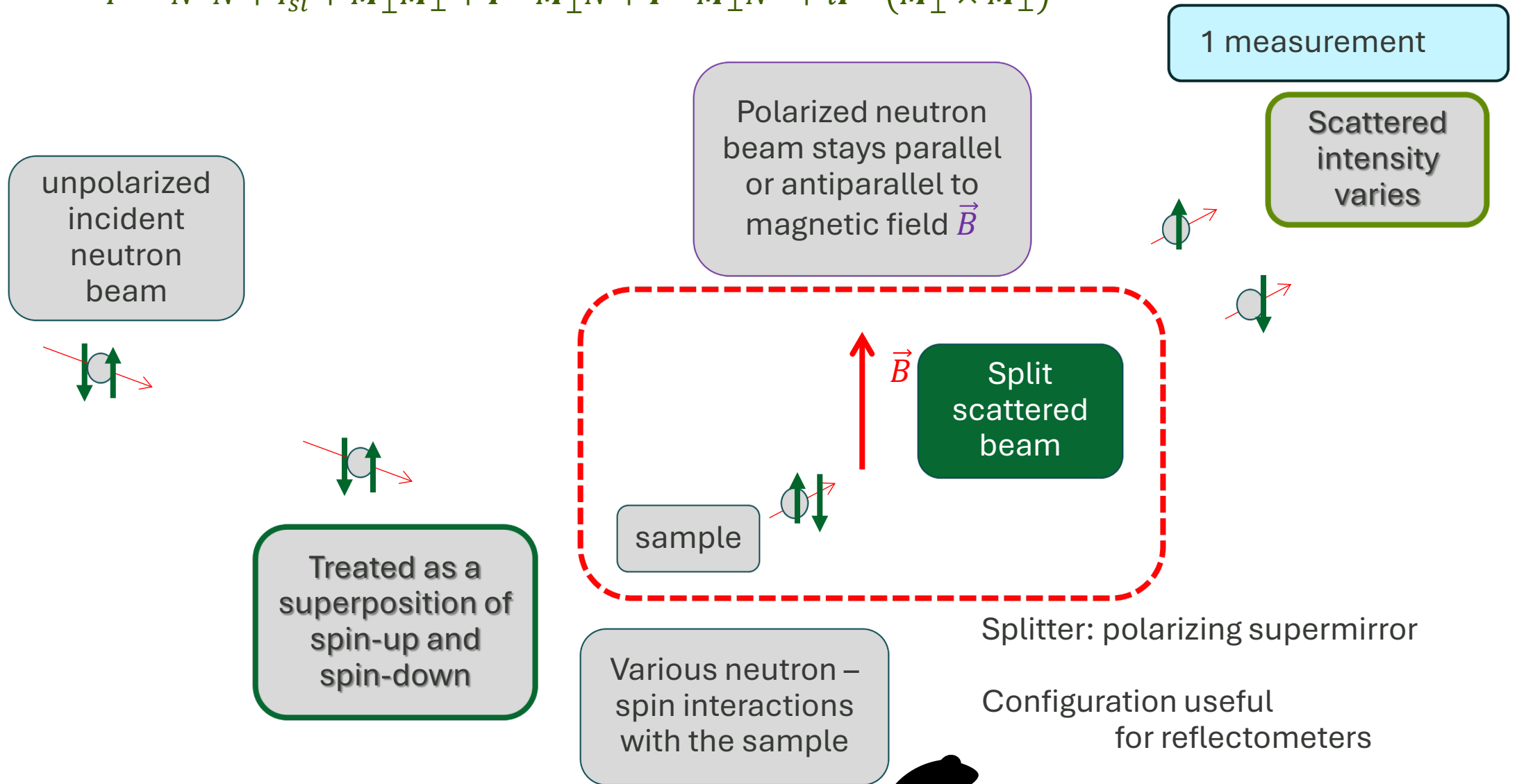

“Half Polarized” Capabilities

$$I = \underbrace{N^\dagger N}_{\text{purple}} + I_{si} + \underbrace{M_\perp^\dagger M_\perp}_{\text{green}} + \underbrace{P \cdot M_\perp^\dagger N}_{\text{green}} + \underbrace{P \cdot M_\perp N^\dagger}_{\text{green}} + \underbrace{iP \cdot (M_\perp^\dagger \times M_\perp)}_{\text{purple}}$$



Separate magnetic susceptibility from nuclear and spin-incoherent signal



Solve the phase problem using an additional magnetic layer



Identify coinciding of nuclear and magnetic coherent scattering in reciprocal space



Identify presence but not direction of a magnetic chiral structure



Magnon energy gain OR energy loss



Enhance coherent scattering contrast and S:N for hydrogen

Capabilities are ‘word problems’ in reverse!

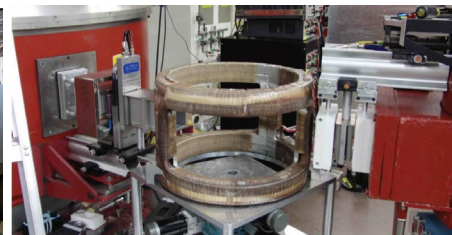
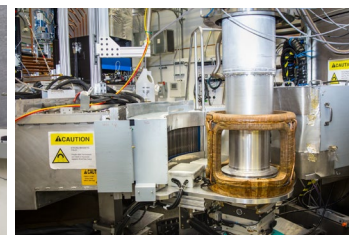
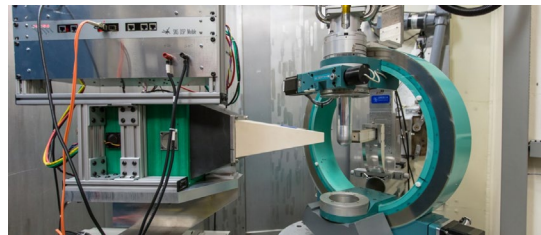

'polarized' or 'dominant domain' samples important for half-polarized configuration

4

This time, we're NOT referring to polarization of the neutron INSTEAD, we're co-aligning either ATOMIC NUCLEI spins or magnetic moments inside of some material

In this case, the MATERIAL is 'polarized' instead of the neutron!

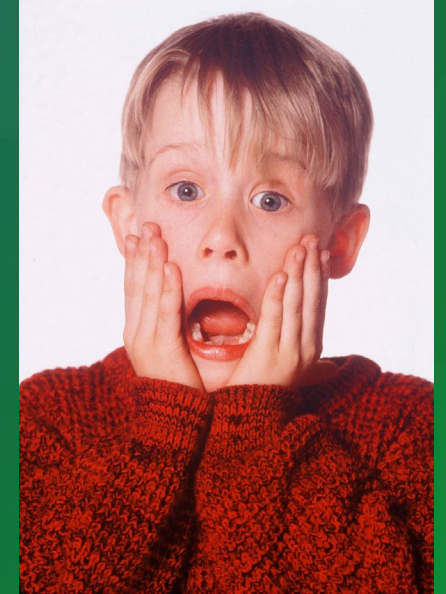

Polarized materials can change scattered intensity* of polarized neutrons

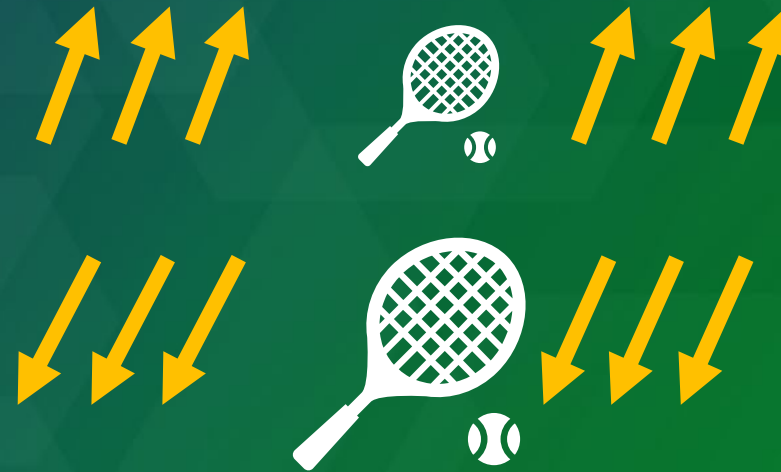

For many Half-polarized measurements, you 'must' magnetically saturate your sample!

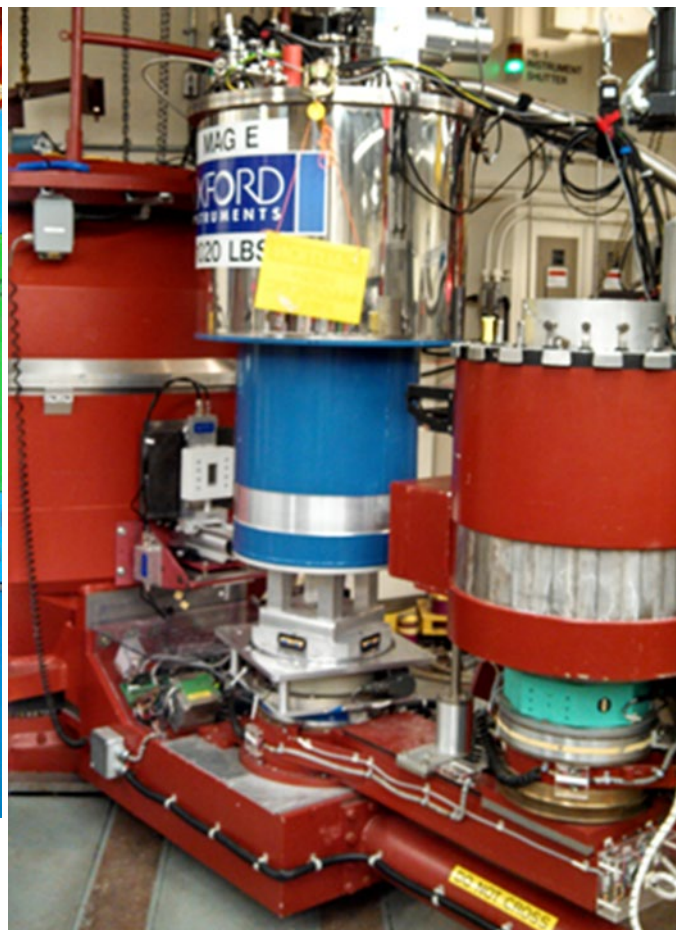

Think 'dominant domain', 'field cooling', etc.

For good Nutation, please be Nimble around the Nodes

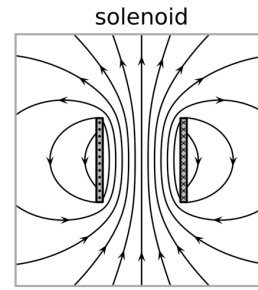

The field inverts, moving from outside to inside & back. There's a 0-point ring with no field, often close to beam elevation

Asymmetric magnet

Move the node vertically out of the beam by having a vertical-bore split-coil magnet generate slightly higher field in one of the coils.

Compensated magnet

Add an additional outer counter-field coil just outside of the main coils, to suppress the stray fields

-Better for flippers and filters

-Seems to (sometimes) also provide enough field magnitude near a node to preserve polarization.

Beware the Bar magnet

Bar magnets can also introduce wild swings in field direction

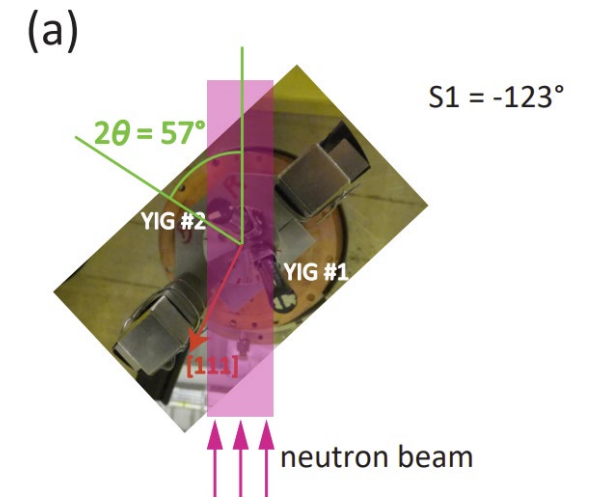



Polarizing supermirrors*

$$\bullet M_{\perp}^{\dagger} M_{\perp} + P \cdot M_{\perp}^{\dagger} N + P \cdot M_{\perp} N^{\dagger} + N^{\dagger} N$$

(but using index of refraction)

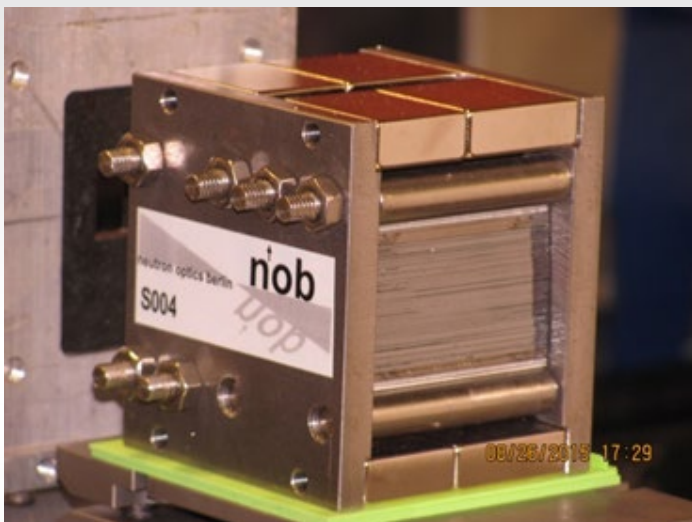

Heusler Bragg Optics

$$\bullet M_{\perp}^{\dagger} M_{\perp} + P \cdot M_{\perp}^{\dagger} N + P \cdot M_{\perp} N^{\dagger} + N^{\dagger} N$$

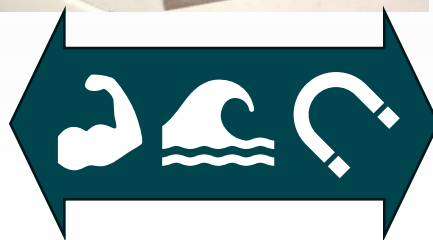

³He filters

$$\sigma_{abs}^u \Rightarrow \sigma_{abs}^{\uparrow\downarrow} + \sigma_{abs}^{\downarrow\downarrow} \Rightarrow \sigma_{abs}^{\uparrow\downarrow}$$

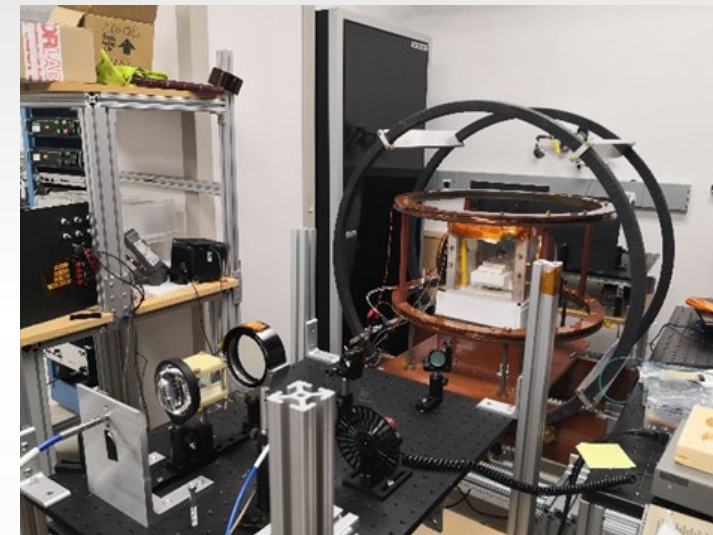

Absorption  

These also demonstrate different ways (Capabilities) to access changes in the Maleev-Blume intensity equation

*Supermirrors don't strictly arise from the Maleev-Blume equations...

Dynamic Nuclear Polarization at IMAGINE

↑ Better
↓ Incoherent Character
 Coherent

Anti-aligned

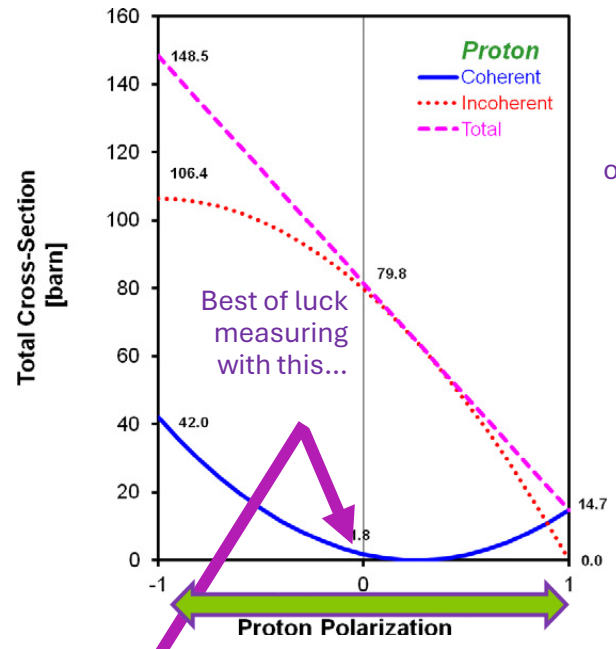
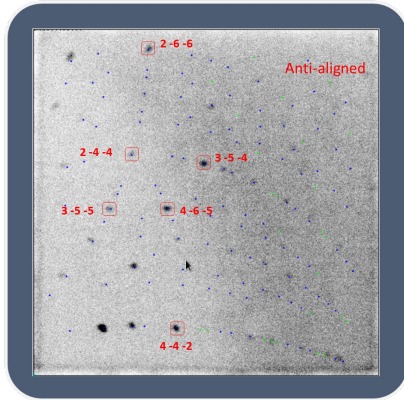
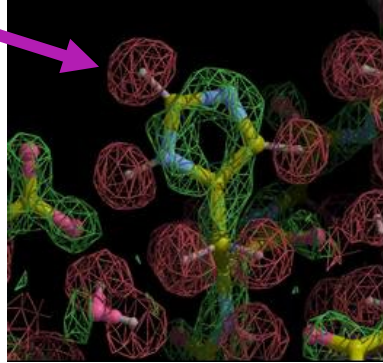

Unpolarized

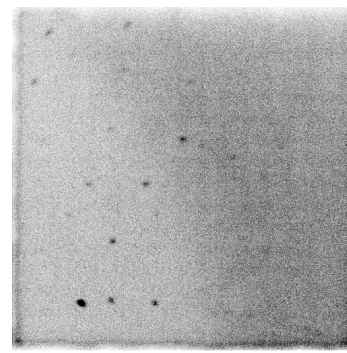
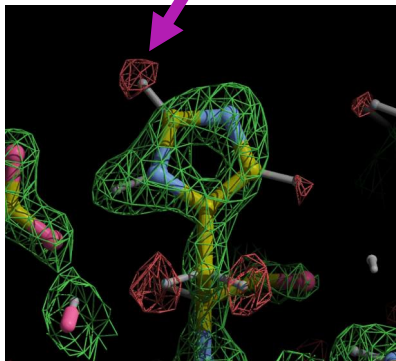

Aligned

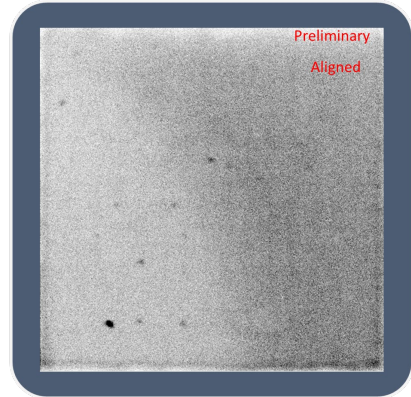
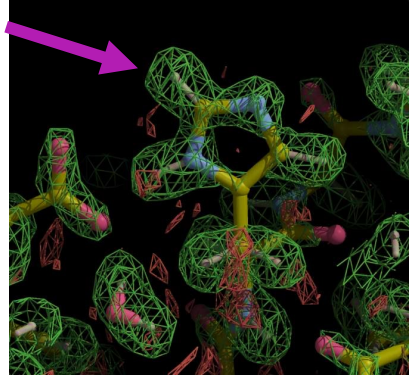

Anti-aligned - Aligned

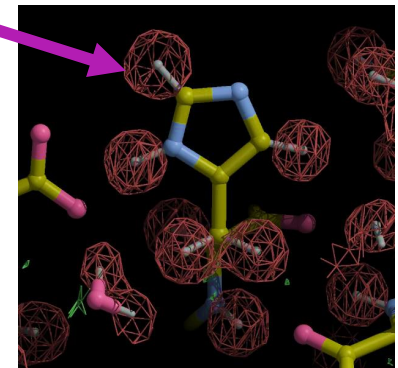

Cross sections tabulated for 'thermal' neutrons



Column

- 1: ZSymbA nuclide: charge number Z - element symbol - mass number A
- 2: p or $T_{1/2}$ abundance (in %) or half-live $T_{1/2}$
- 3: I nuclear spin I
- 4: b_c bound coherent scattering length (in fm)
- 5: b_+ spin-dependent scattering length for $I+1/2$ (in fm)
- 6: b_- spin-dependent scattering length for $I-1/2$ (in fm)
- 7: c indication whether separate (b_+ - b_-) values are available (+/-) and/or a strong energy dependence exists (E)
- 8: σ_{coh} coherent cross section in barn
- 9: σ_{inc} incoherent cross section in barn
- 10: σ_{scatt} total cross section in barn
- 11: σ_{abs} thermal absorption cross section in barn for 0.0253 eV
- * stands for estimated values

ZSymbA	p or $T_{1/2}$	I	b_c	b_+	b_-	c	σ_{coh}	σ_{inc}	σ_{scatt}	σ_{abs}
0-N-1	10.3 MIN	1/2	-37.0(6)	0	-37.0(6)		43.01(2)		43.01(2)	0
1-H			-3.7409(11)				1.7568(10)	80.26(6)	82.02(6)	0.3326(7)
1-H-1	99.985	1/2	-3.7423(12)	10.817(5)	-47.420(14)	+/-	1.7583(10)	80.27(6)	82.03(6)	0.3326(7)
1-H-2	0.0149	1	6.674(6)	9.53(3)	0.975(60)		5.592(7)	2.05(3)	7.64(3)	0.000519(7)
1-H-3	12.26 Y	1/2	4.792(27)	4.18(15)	6.56(37)		2.89(3)	0.14(4)	3.03(5)	< 6.0E-6
2-He			3.26(3)				1.34(2)	0	1.34(2)	0.00747(1)
2-He-3	0.00013	1/2	5.74(7)	4.374(70)	9.835(77)	E	4.42(10)	1.532(20)	6.0(4)	5333.0(7.0)
2-He-4	0.99987	0	3.26(3)				1.34(2)	0	1.34(2)	0
3-Li			-1.90(3)				0.454(10)	0.92(3)	1.37(3)	70.5(3)
3-Li-6	7.5	1	2.0(1)	0.67(14)	4.67(17)	+/-	0.51(5)	0.46(5)	0.97(7)	940.0(4.0)
3-Li-7	92.5	3/2	-2.22(2)	-4.15(6)	1.00(8)	+/-	0.619(11)	0.78(3)	1.40(3)	0.0454(3)
4-Be-9	100	3/2	7.79(1)				7.63(2)	0.0018(9)	7.63(2)	0.0076(8)
5-B			5.30(4)				3.54(5)	1.70(12)	5.24(11)	767.0(8.0)
5-B-10	19.4	3	-0.2(4)	-4.2(4)	5.2(4)		0.144(6)	3.0(4)	3.1(4)	3835.0(9.0)
5-B-11	80.2	3/2	6.65(4)	5.6(3)	8.3(3)		5.56(7)	0.21(7)	5.77(10)	0.0055(33)
6-C			6.6484(13)				5.551(2)	0.001(4)	5.551(3)	0.00350(7)

Spin Exchange Optical Pumping for ^3He Filters ALSO leverages Dynamic Nuclear Polarization, but for ^3He nuclei instead of H

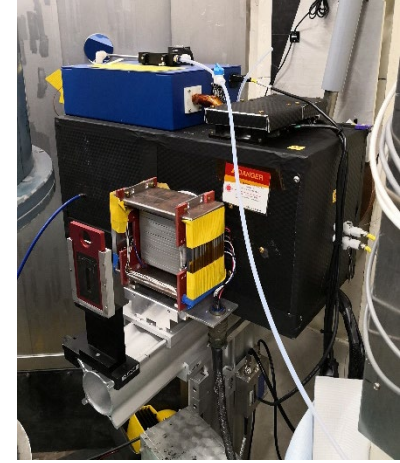
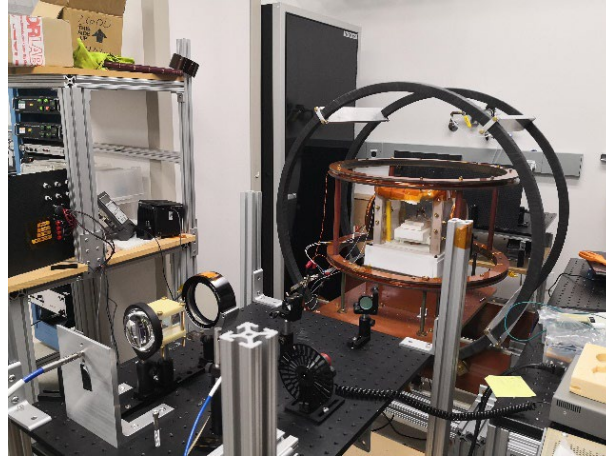
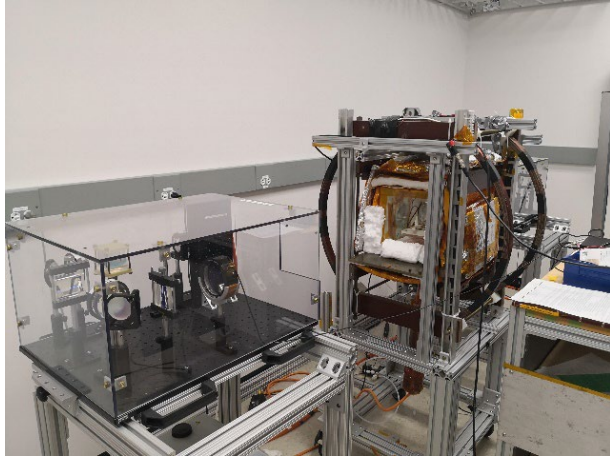

Ex situ pumping stations

^3He polarizer on HB3A

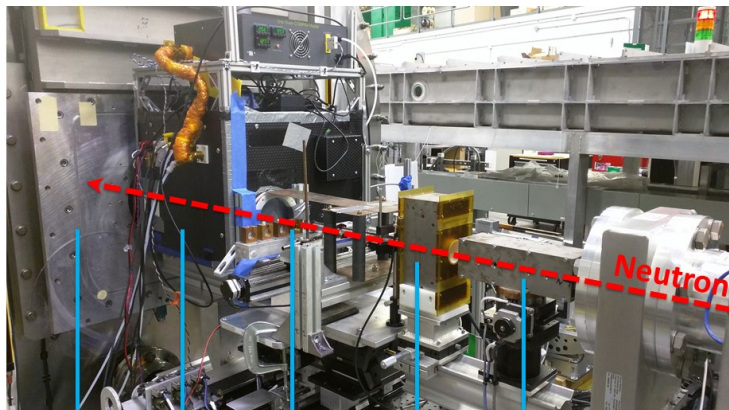

SANS tank | Sample | polarizer
 ^3He analyzer | RF - flipper

Drop-in cell for GPSANS



^3He analyzer on MAGREF

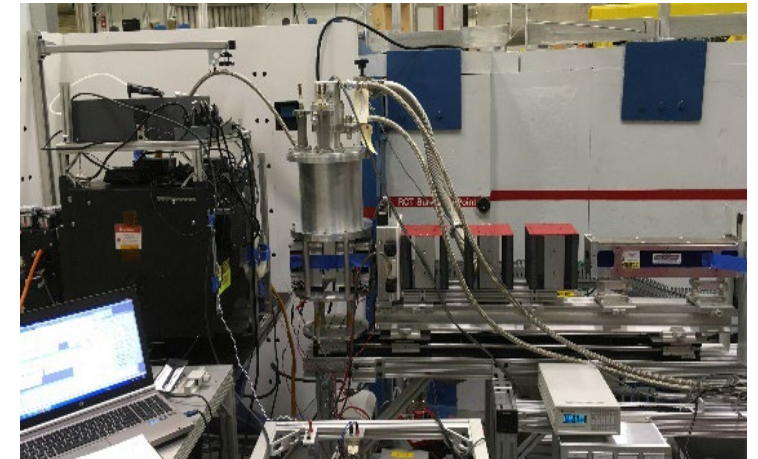

^3He analyzer on IMAGING

Longitudinal Analysis (1) Configuration

2 measurements
Assumes $I^{\uparrow\downarrow} = I^{\downarrow\uparrow}$

$$P^{\uparrow\downarrow}I = P \left(N^{\uparrow\downarrow}N - \frac{1}{3}I_{si} \right) + (P \cdot M_{\perp}^{\uparrow\downarrow})M_{\perp} + (P \cdot M_{\perp})M_{\perp}^{\uparrow\downarrow} - P(M_{\perp}^{\uparrow\downarrow}M_{\perp}) + iN(P \times M_{\perp}^{\uparrow\downarrow}) - iN^{\uparrow\downarrow}(P \times M_{\perp}) + NM_{\perp}^{\uparrow\downarrow} + N^{\uparrow\downarrow}M_{\perp} - i(M_{\perp}^{\uparrow\downarrow} \times M_{\perp})$$

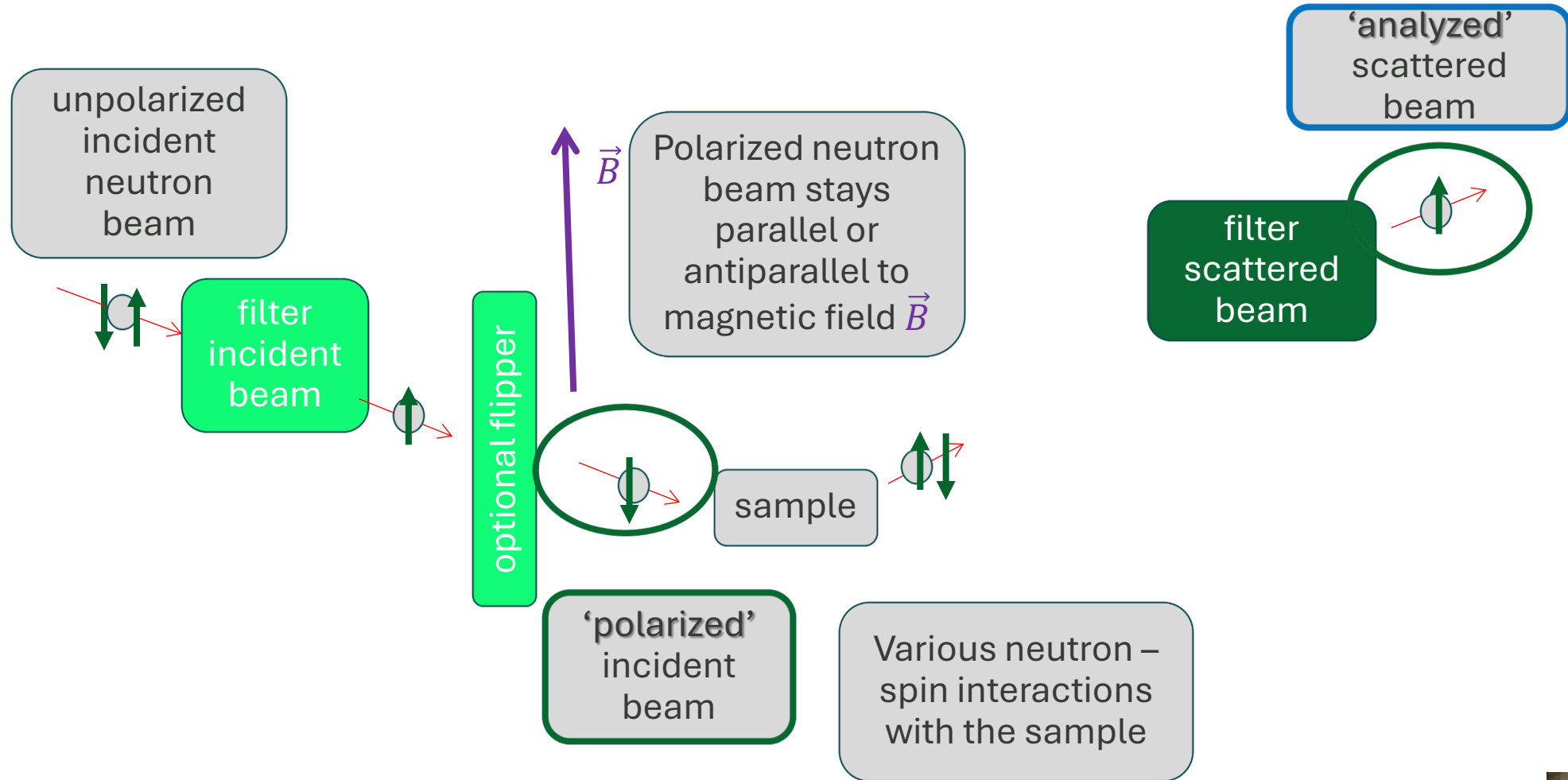

distinguish between spin flip and non-flip at sample

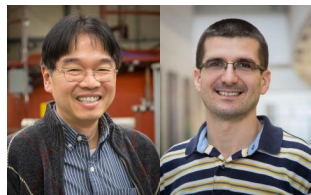

Longitudinal Analysis (1) Capabilities

$$P^{\perp}I = P \left(N^{\dagger}N - \frac{1}{3}I_{si} \right) + (P \cdot M_{\perp}^{\dagger})M_{\perp} + (P \cdot M_{\perp})M_{\perp}^{\dagger} - P(M_{\perp}^{\dagger}M_{\perp}) + iN(P \times M_{\perp}^{\dagger}) - iN^{\dagger}(P \times M_{\perp}) + NM_{\perp}^{\dagger} + N^{\dagger}M_{\perp} - i(M_{\perp}^{\dagger} \times M_{\perp})$$

3D

- ★ Separate nuclear scattering from spin-incoherent scattering
- ★ Separate spin-incoherent scattering from nuclear scattering
- ★ Determine quickly whether a signal is magnetic in origin
- ★ Track an order parameter for ferromagnetism of a powder via depolarization of thru beam
- ★ Separate nuclear scattering from both spin-incoherent scattering and magnetic scattering
- ★ Separate spin-incoherent scattering from both both nuclear scattering and magnetic scattering
- ★ Quantify the isotropic magnetic moment magnitude via separation from nuclear and spin-incoherent scattering
- ★ Quantify the magnetic moment magnitude and direction and separate it form both nuclear and spin-incoherent scattering
- ★ Enhance coherent scattering contrast and S:N for hydrogen and Separate from spin-incoherent scattering

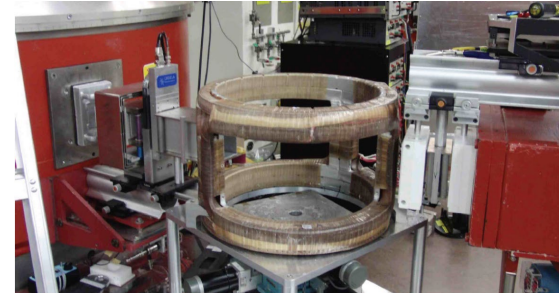
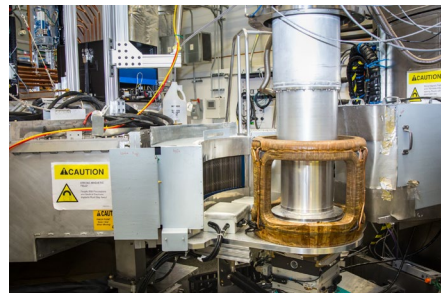
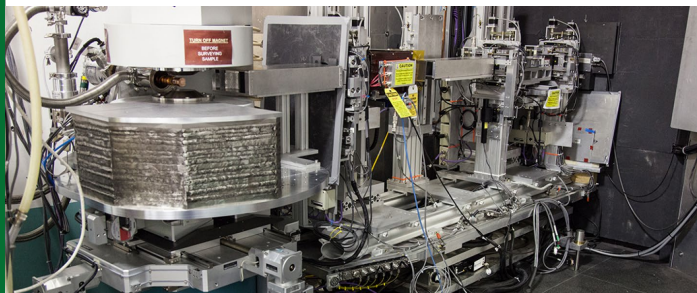

HYSPEC: Data correction in polarization configuration

Most characterization measurements with **TiZr** (Nuclear incoherent)
Vanadium (Spin incoherent) and **Quartz** (Nuclear incoherent)

Non Spin Flip: $I^{\nu\nu} = N^*N + M_{\perp}^{\nu}M_{\perp}^{\nu*} + NM_{\perp}^{\nu*} + N^*M_{\perp}^{\nu} + 1/3 I_{SI}$

Spin Flip: $I^{\nu\bar{\nu}} = \vec{M}_{\perp}\vec{M}_{\perp}^* - M_{\perp}^{\nu}M_{\perp}^{\nu*} + i(\vec{M}_{\perp} \times \vec{M}_{\perp}^*)^{\nu} + 2/3 I_{SI}$

FR = $\frac{I_{NSF}}{I_{SF}}$; Correct for flipping $SF_{corr} = \frac{F}{F-1} SF + \frac{1}{F-1} NSF$

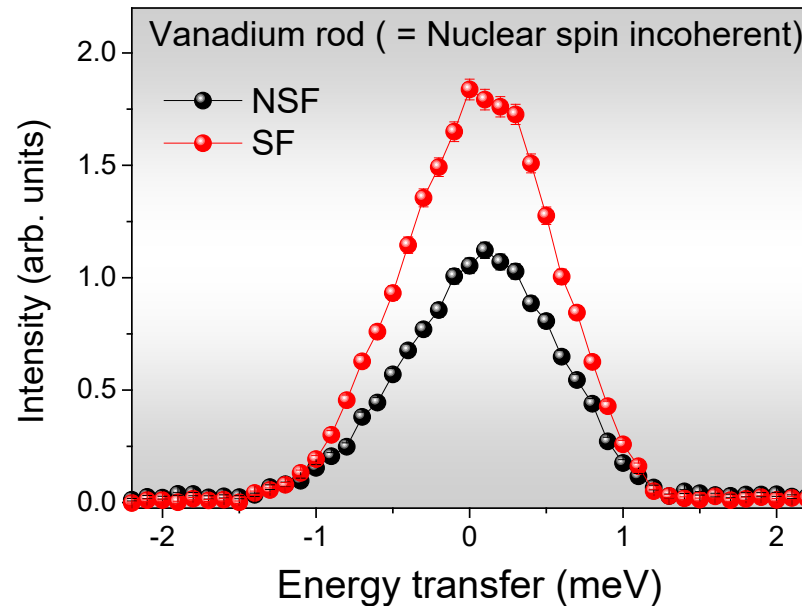
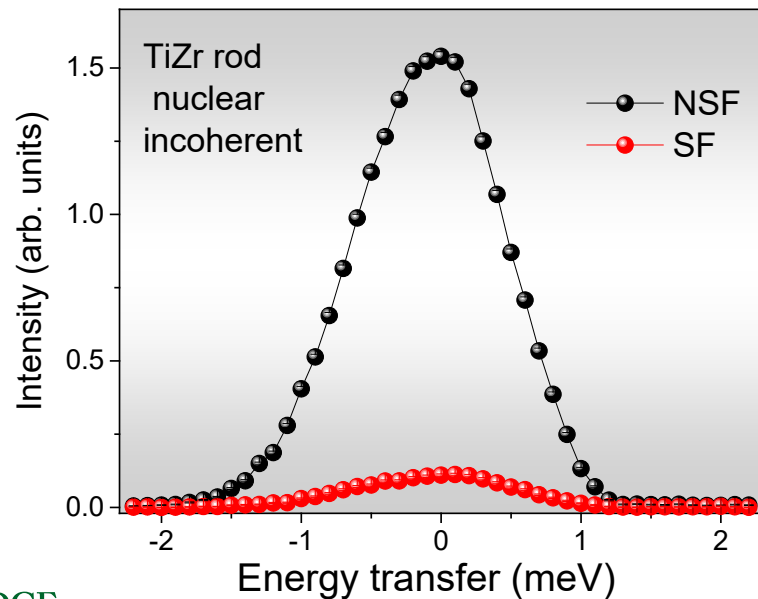

A tale of two incoherent scatterers, and how we measure flipping ratios

Vanadium, spin incoherent

ZSymbA	p or T _{1/2}	I	b _c	b ₊	b ₋	c	σ _{coh}	σ _{inc}
23-V-50	0.25	6	7.6(6)*				7.3(1.1)	0.5(5)*
23-V-51	99.75	7/2	-0.402(2)	4.93(25)	-7.58(28)	+/-	0.0203(2)	5.07(6)

$$I = 7/2$$

Squires (2.71) through (2.75) only refer to scattering frequency, not chances of spin-flip or non-spin flip

Squires (9.25) through (9.30) discuss spin-incoherent scattering with spin-flip (SF=2/3) & non-spin-flip (NSF=1/3)

Enemy of 2/3 vs 1/3 SF vs NSF is MULTIPLE SCATTERING, so prefer skinny, annulus, or flat plate...



TiZr, isotope incoherent

How does one get spin-incoherent scattering from two (partly) coherently scattering elements!?!?

ZSymbA	p or T _{1/2}	I	b _c	b ₊	b ₋	c	σ _{coh}	σ _{inc}
22-Ti			-3.370(13)				1.485(2)	2.87(3)
22-Ti-46	8	0	4.72(5)				3.05(7)	0
22-Ti-47	7.5	5/2	3.53(7)	0.46(23)	7.64(13)		1.66(11)	1.5(2)
22-Ti-48	73.7	0	-5.86(2)				4.65(3)	0
22-Ti-49	5.5	7/2	0.98(5)	2.6(3)	-1.2(4)		0.14(1)	3.3(3)
22-Ti-50	5.3	0	5.88(10)				4.80(12)	0
40-Zr			7.16(3)				6.44(5)	0.02(15)
40-Zr-90	51.48	0	6.5(1)				5.1(2)	0
40-Zr-91	11.23	5/2	8.8(1)	7.9(2)	10.1(2)	+/-	9.5(2)	0.15(4)
40-Zr-92	17.11	0	7.5(2)				6.9(4)	0
40-Zr-94	17.4	0	8.3(2)				8.4(4)	0
40-Zr-96	2.8	0	5.5(1)				3.8(1)	0

How does one get spin-incoherent scattering from two (partly) coherently scattering elements!?!?

Squires (2.60) through (2.70), &
 $b_{c Ti} \approx -\frac{1}{2} b_{c Zr}$ lead to
 $(\bar{b})^2 \approx 0$ and $\overline{b^2} \neq 0$

Other routes to flipping ratio

Nuclear coherent scattering

- Quartz, broad features
- Vycor® porous glass, small angle scattering from the air bubbles

Non-spin-flip from (only) nuclear Bragg peaks

Spin-flip from uniquely magnetic Bragg peaks

For superconducting samples (no spherical neutron polarimetry), one needs several FR's at different omegas to account for variations in depolarization

Longitudinal Analysis (2) Configuration

4 measurements
12 for 3D
Allows $I^{\uparrow\downarrow} \neq I^{\downarrow\uparrow}$

$$I = N^\dagger N + I_{si} + \mathbf{M}_\perp^\dagger \mathbf{M}_\perp + \mathbf{P} \cdot \mathbf{M}_\perp^\dagger N + \mathbf{P} \cdot \mathbf{M}_\perp N^\dagger + i\mathbf{P} \cdot (\mathbf{M}_\perp^\dagger \times \mathbf{M}_\perp)$$

$$P^\dagger I = P \left(N^\dagger N - \frac{1}{3} I_{si} \right) + (P \cdot \mathbf{M}_\perp^\dagger) \mathbf{M}_\perp + (P \cdot \mathbf{M}_\perp) \mathbf{M}_\perp^\dagger - P(\mathbf{M}_\perp^\dagger \mathbf{M}_\perp) + iN(P \times \mathbf{M}_\perp^\dagger) - iN^\dagger(P \times \mathbf{M}_\perp) + N\mathbf{M}_\perp^\dagger + N^\dagger\mathbf{M}_\perp - i(\mathbf{M}_\perp^\dagger \times \mathbf{M}_\perp)$$

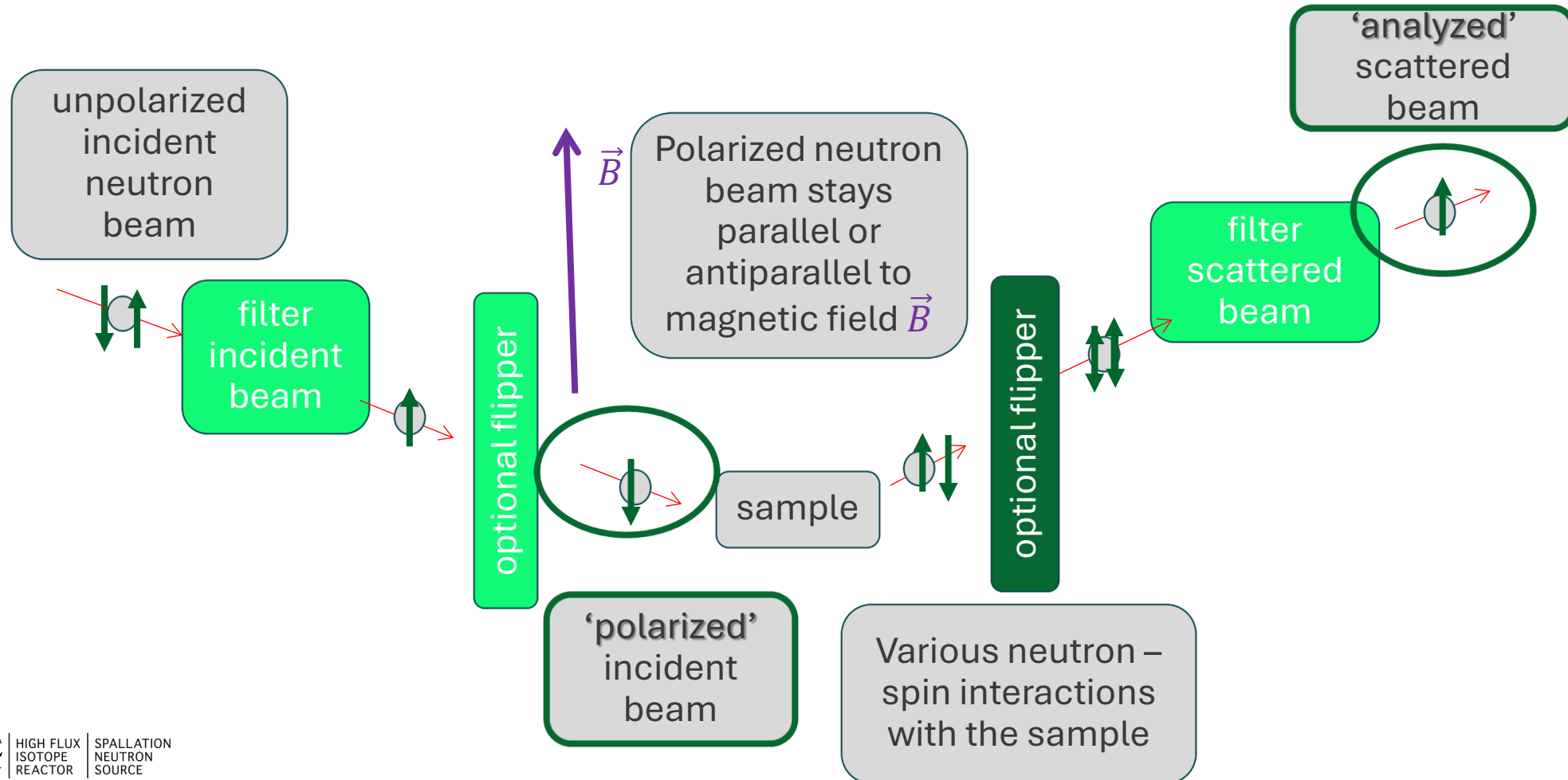

Equivalent Longitudinal Analysis (2) Configuration for MAGREF

2 measurements for
MAGREF 1D

$$I = N^\dagger N + I_{si} + \mathbf{M}_\perp^\dagger \mathbf{M}_\perp + \mathbf{P} \cdot \mathbf{M}_\perp^\dagger N + \mathbf{P} \cdot \mathbf{M}_\perp N^\dagger + i\mathbf{P} \cdot (\mathbf{M}_\perp^\dagger \times \mathbf{M}_\perp)$$

$$P^\dagger I = P \left(N^\dagger N - \frac{1}{3} I_{si} \right) + (P \cdot \mathbf{M}_\perp^\dagger) \mathbf{M}_\perp + (P \cdot \mathbf{M}_\perp) \mathbf{M}_\perp^\dagger - P(\mathbf{M}_\perp^\dagger \mathbf{M}_\perp) + iN(P \times \mathbf{M}_\perp^\dagger) - iN^\dagger(P \times \mathbf{M}_\perp) + N\mathbf{M}_\perp^\dagger + N^\dagger \mathbf{M}_\perp - i(\mathbf{M}_\perp^\dagger \times \mathbf{M}_\perp)$$

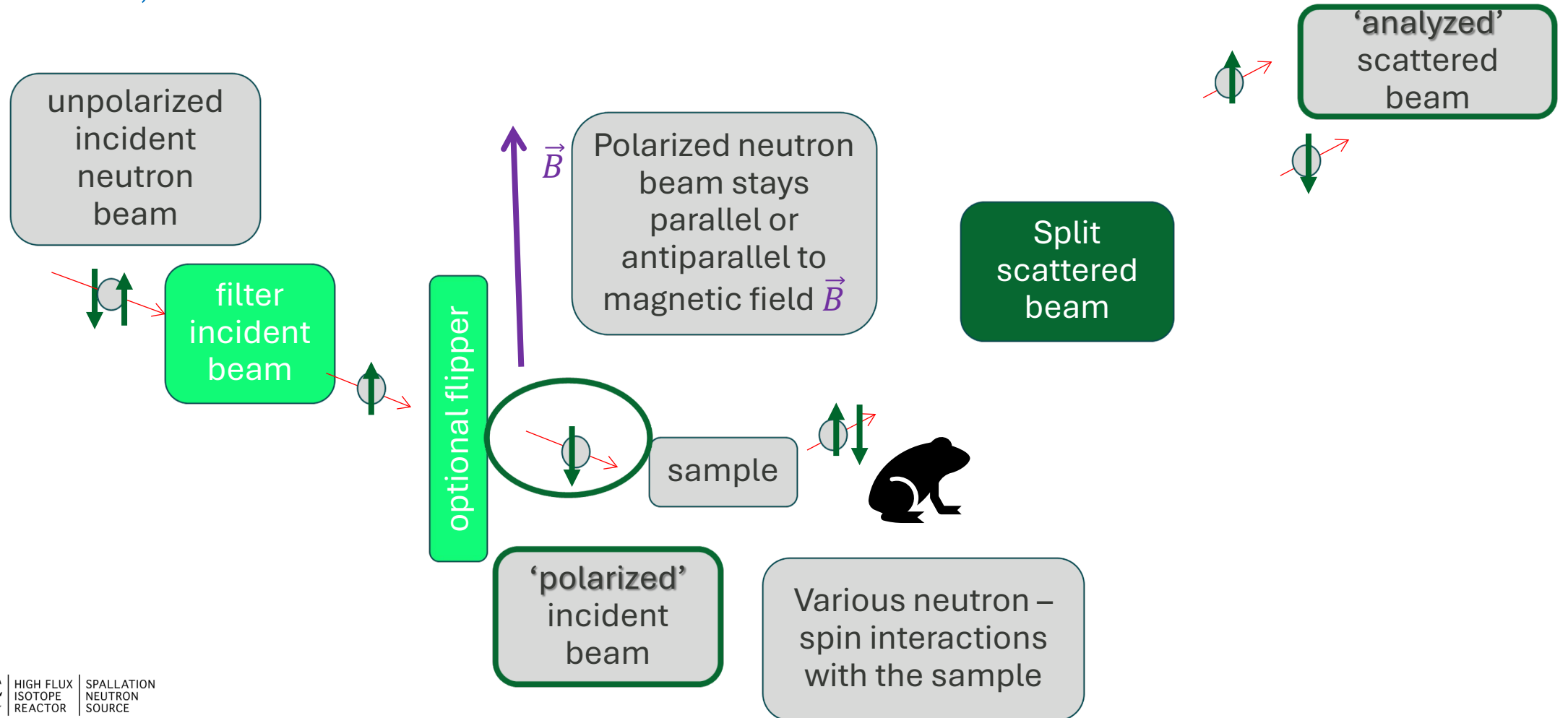

Flip for horizontal field-at-sample using 3D coils

4 measurements
12 for 3D
Allows $I^{\uparrow\downarrow} \neq I^{\downarrow\uparrow}$

$$I = N^\dagger N + I_{si} + \mathbf{M}_\perp^\dagger \mathbf{M}_\perp + \mathbf{P} \cdot \mathbf{M}_\perp^\dagger N + \mathbf{P} \cdot \mathbf{M}_\perp N^\dagger + i\mathbf{P} \cdot (\mathbf{M}_\perp^\dagger \times \mathbf{M}_\perp)$$

$$P^\dagger I = P \left(N^\dagger N - \frac{1}{3} I_{si} \right) + (P \cdot \mathbf{M}_\perp^\dagger) \mathbf{M}_\perp + (P \cdot \mathbf{M}_\perp) \mathbf{M}_\perp^\dagger - P(\mathbf{M}_\perp^\dagger \mathbf{M}_\perp) + iN(P \times \mathbf{M}_\perp^\dagger) - iN^\dagger(P \times \mathbf{M}_\perp) + N\mathbf{M}_\perp^\dagger + N^\dagger \mathbf{M}_\perp - i(\mathbf{M}_\perp^\dagger \times \mathbf{M}_\perp)$$

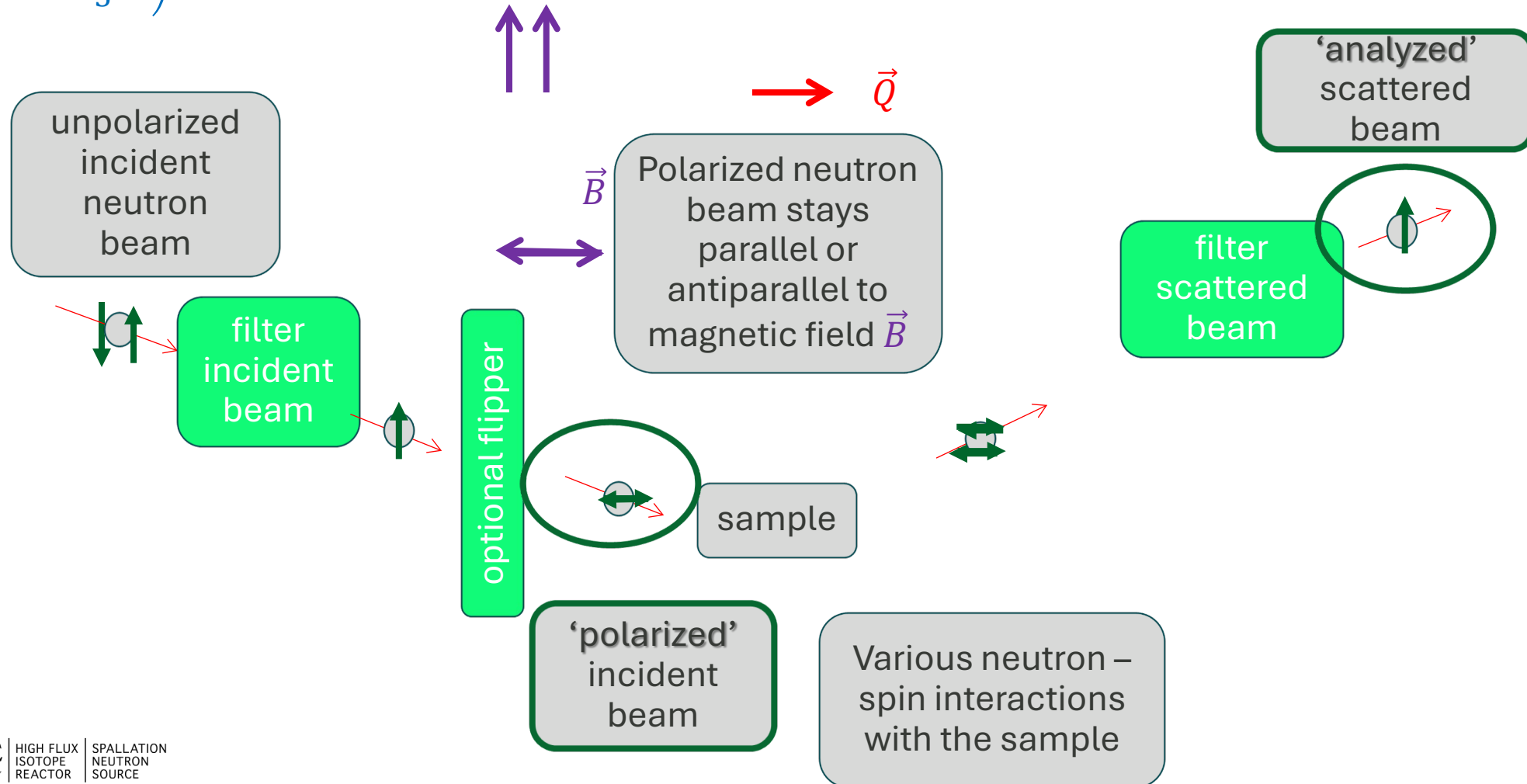

✓ Description of linear neutron polarization analysis technique - 1969

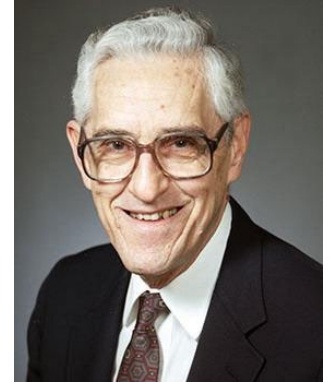

Ralph Moon
1929-2004

PHYSICAL REVIEW

VOLUME 181, NUMBER 2

10 MAY 1969

Polarization Analysis of Thermal-Neutron Scattering*

R. M. MOON, T. RISTE,[†] AND W. C. KOEHLER

Solid State Division, Oak Ridge National Laboratory, Oak Ridge, Tennessee 37830

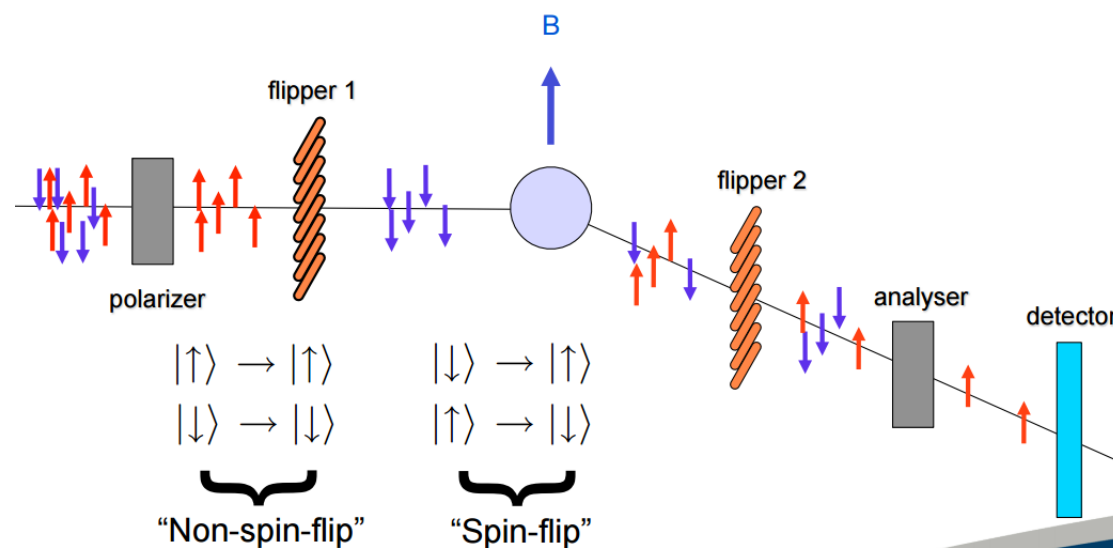

- Only the moment component perpendicular to Q is observed (S_{perp})
- Scattering depends on the direction of polarization vector (P) with respect to Q :

$P \parallel Q$ or $P \perp Q$ (for single detector)

$$U^{++} = b - pS_{\perp z} + BI_z,$$

$$U^{--} = b + pS_{\perp z} - BI_z,$$

$$U^{+-} = -p(S_{\perp x} + iS_{\perp y}) + B(I_x + iI_y),$$

$$U^{-+} = -p(S_{\perp x} - iS_{\perp y}) + B(I_x - iI_y).$$

Longitudinal Analysis 2 Capabilities

$$I = N^\dagger N + I_{si} + \underline{M_\perp^\dagger M_\perp} + \underline{P \cdot M_\perp^\dagger N} + \underline{P \cdot M_\perp N^\dagger} + i \underline{P \cdot (M_\perp^\dagger \times M_\perp)}$$

$$P^\dagger I = \underline{P \left(N^\dagger N - \frac{1}{3} I_{si} \right)} + \underline{(P \cdot M_\perp^\dagger) M_\perp} + \underline{(P \cdot M_\perp) M_\perp^\dagger} - \underline{P (M_\perp^\dagger M_\perp)} + i N (P \times M_\perp^\dagger) - i N^\dagger (P \times M_\perp) + \underline{N M_\perp^\dagger} + \underline{N^\dagger M_\perp} - i (M_\perp^\dagger \times M_\perp)$$

- ★ Quantify magnetic moment and direction
- ★ Quantify 3D aspect of the coinciding of nuclear and magnetic coherent scattering in reciprocal space
- ★ Partly quantify chiral magnetic structure or dynamics

Demonstration experiment **N20** leverages the **Longitudinal 2** configuration

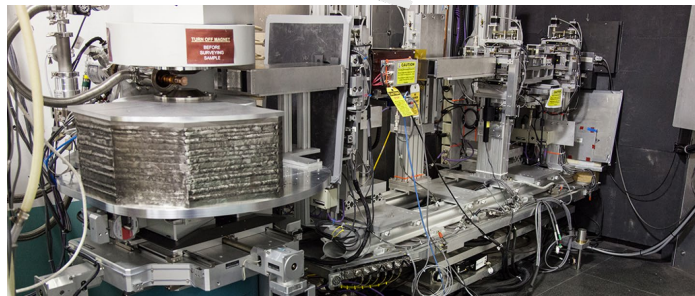

Rarely used.
Impossible with magnet due to size restrictions

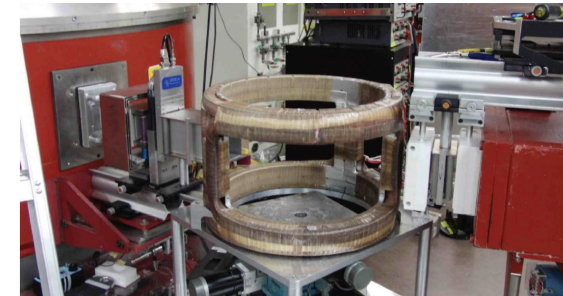

Complementarity between polarized neutron scattering -&- X-ray magnetic circular dichroism

- In addition to the other pro's & con's comparing neutrons & x-rays...

Polarized neutrons

polarized diffraction goes beyond
element specificity to lattice-site-
specific moment measurements

Not element specific in general

Relatively direct measurement of
magnetism

Indirectly could leverage neutron
isotope specificity, possibly with
coherent interference effects

X-ray dichroism

Element specificity near absorption
edges

Access to magnetism when x-rays
excite an electron that contributes
to magnetism
(transition metals -d electrons
→L x-ray edges)

Calculation gymnastics

Potentially separate magnetism into
orbital and spin moments





Demystifying and expanding the Polarization Neutron Optics collection

Spherical Neutron Polarimetry as special case



Adiabatic vs non-Adiabatic



Adiabatic: Neutron moment follows the field

$$\vec{\tau} = \vec{\mu} \times \vec{B}, \omega_L = -\gamma B$$

$$\frac{\omega_L}{\omega_B} > \sim 10$$

Guide fields & Nutation

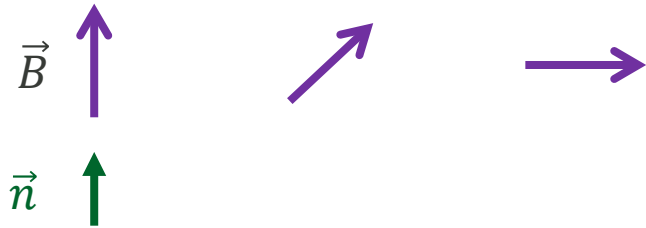

Nuclear Magnetic Resonance: neutron moment, while precessing, can 'catch' a resonant photon and follow it upside down

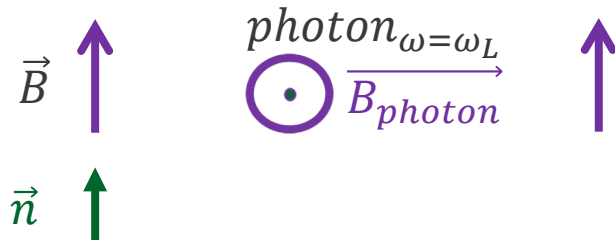

Non-Adiabatic: Field direction or magnitude change is 'too rapid' so neutron moment 'stays'

$$\frac{\omega_L}{\omega_B} \ll 1$$

Neutron observes 'instantaneous' change in magnetic field as it passes through some kind of field barrier

Neutron has 'no time' to respond to change

Can be field direction change

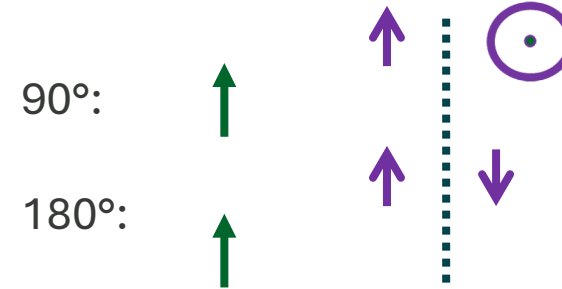

or magnitude change to zero field (or back)



How Mezei flippers work



Refresher: Solenoid coils

0 field outside, uniform field inside, for uniform cylindrical shape infinitely long & high coil density

$$\begin{aligned} \vec{B}_{inside} &= \mu_0 N I \hat{z} \\ \vec{B}_{outside} &= 0 \end{aligned}$$

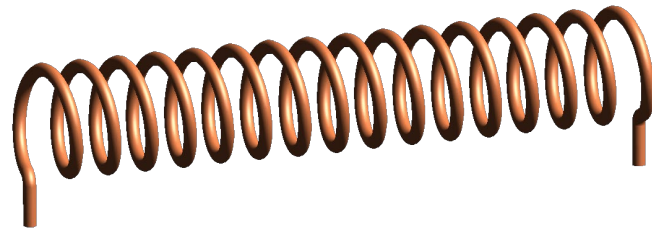

Approximation with finite length & rectangular cross section

Mezei flipper diagram

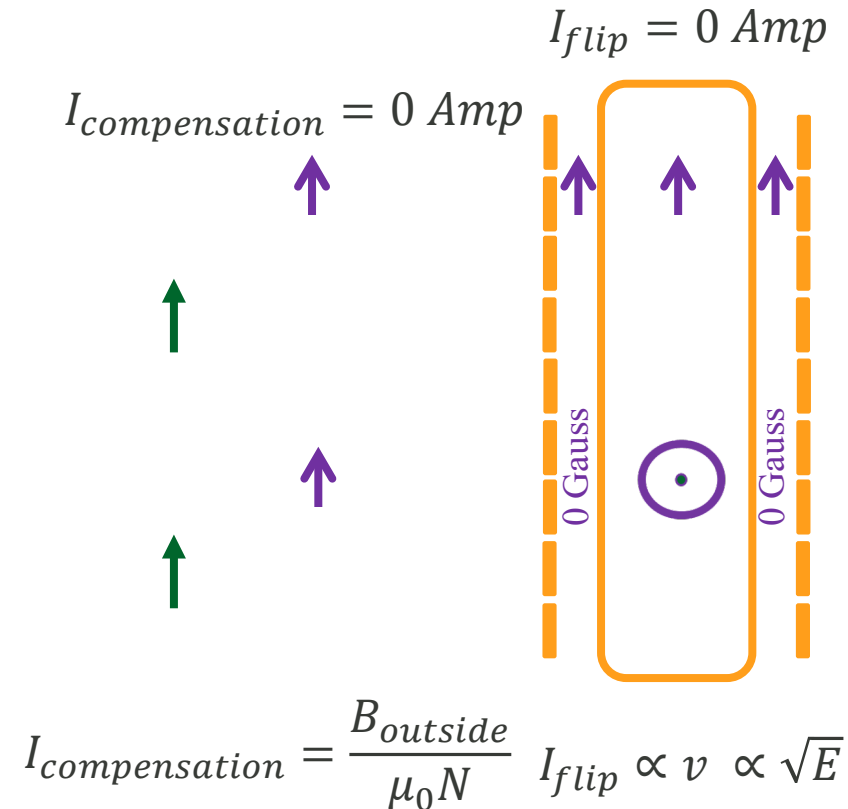

Field suppression

'Suck in' high permeability, μ -metal (or permalloy)

80% nickel 20% iron alloy

Needs annealing and doesn't like to be sneezed at

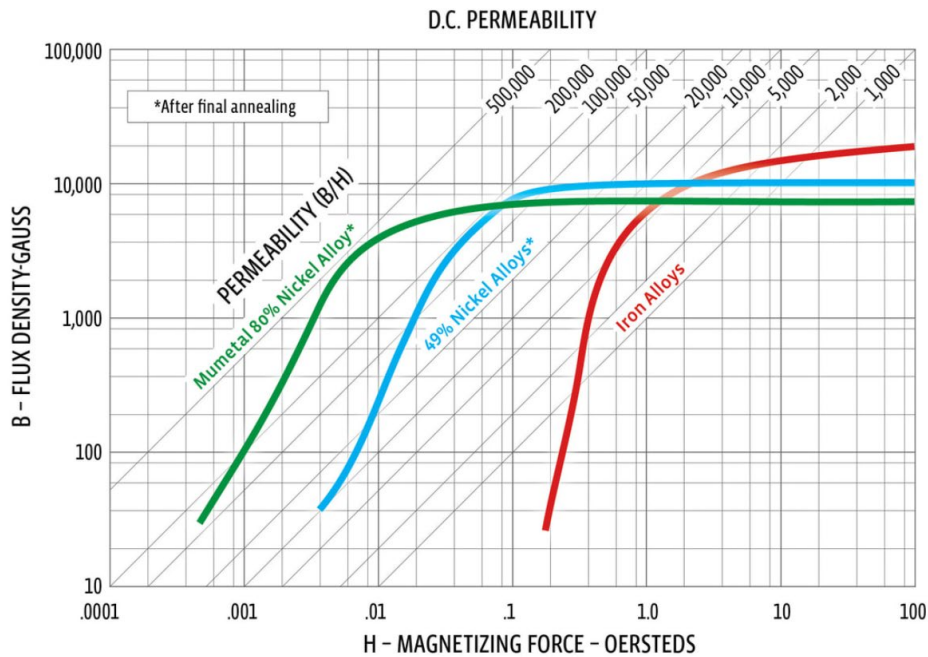

'Rejection' via superconductor, Meissner effect

Implication: below T_c , field next to superconductor prefers to be tangent to surface...

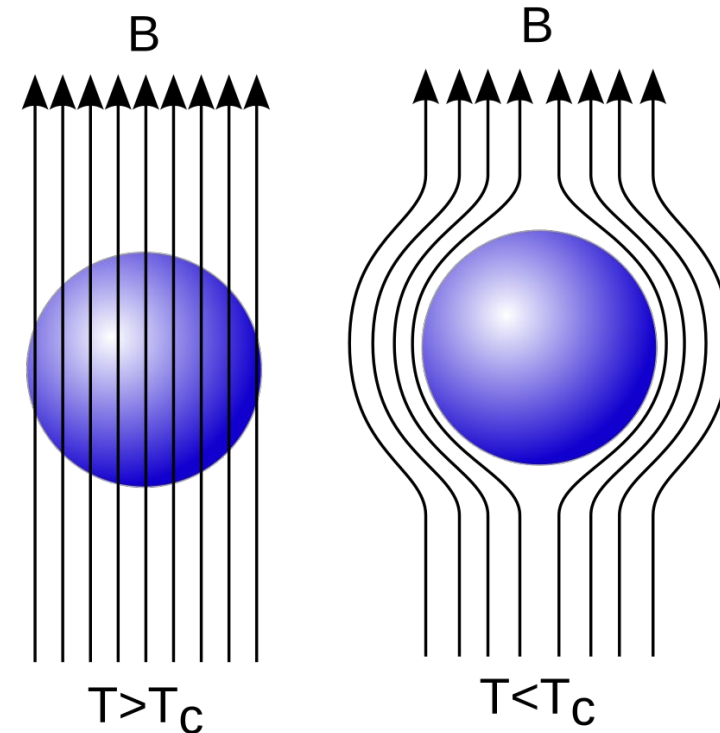

Other non-adiabatic flippers which leverage abrupt field reversal (180°, full 'flip in one go...)



Drabkin flipper

Dabbs Foil (current sheet)

Cryo flipper (Meissner screen)

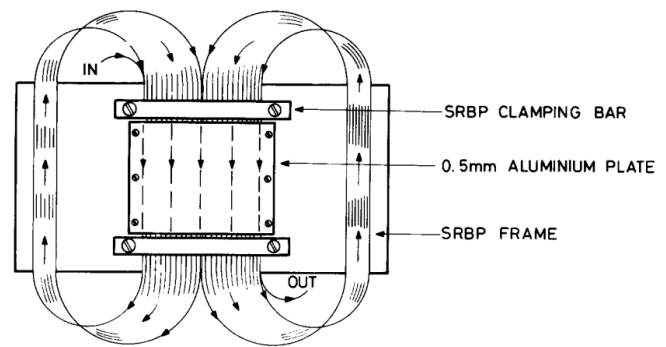
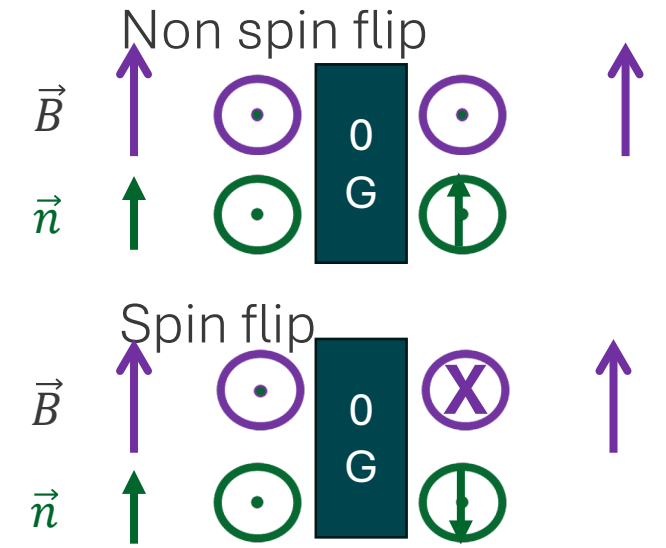
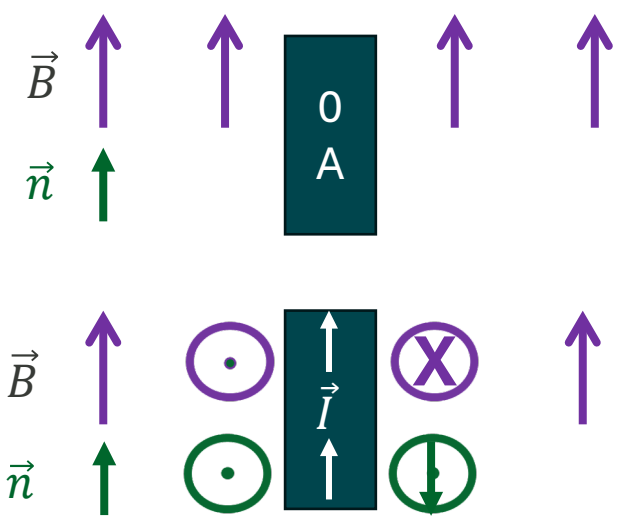
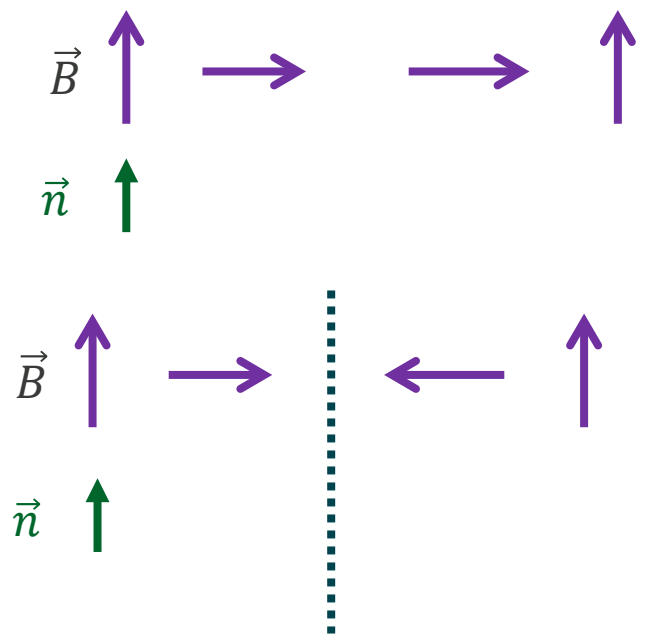
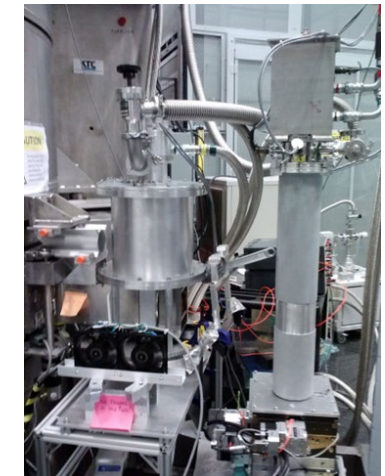
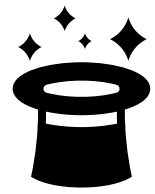

Fig. 6. Multiwire current sheet spin flipper.



NMR-style flippers



Refresher: Nuclear magnetic resonance

$$\vec{B}_{static} \perp \vec{B}_{RF}$$

Fun fact: Those neutrons or nuclei with moments aligned with B have slightly more energy than those anti-aligned (small energies; don't worry!)

So, while we discussed the classical (adiabatic) perspective already, one can from a quantum mechanical perspective view this as either photon absorption (anti- to aligned), or resonant emission (aligned to anti-)

For a neutron:
$$\Delta E = \frac{\mu}{I} H m = \frac{-1.913 \cdot 5.051 \times 10^{-27} \frac{J}{T} \frac{1000 \text{ meV}}{1.6 \times 10^{-19} J}}{0.5} (\sim 10^{-3} T)(\pm 1) \cong 2 \times 10^{-7} \text{ meV}$$

RF flippers: NMR on the neutron itself

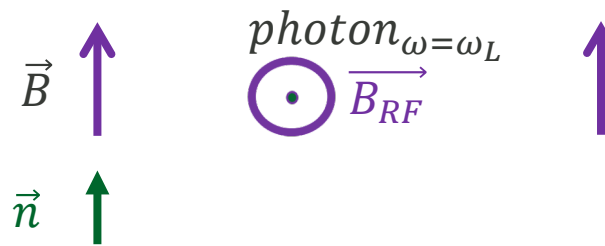

Vary Larmor precession frequency via varying guide field strength $|\vec{B}_{guide}|$ while keeping $\vec{B}_{guide} \perp \vec{B}_{RF}$

Adiabatic Fast Passage: NMR on nuclei of ^3He

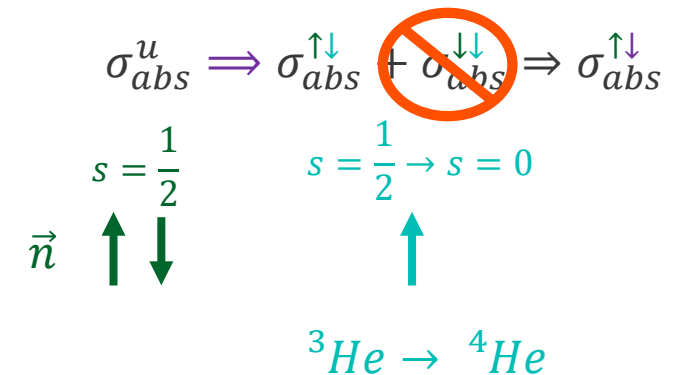

Vary RF frequency

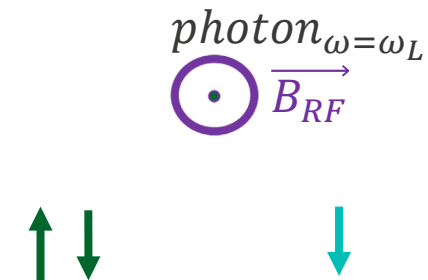

Both a filter AND a flipper!

Flippers finally explained!



Mezei flipper & precession chamber

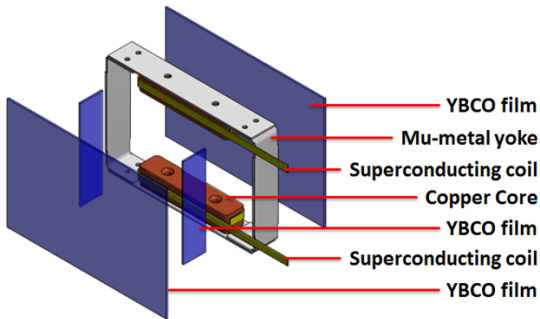
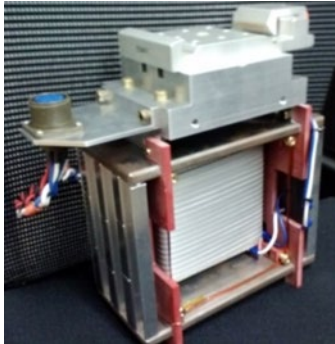

Radio Frequency flipper

Think: NMR on the neutron in flight



Adiabatic Fast Passage Flipper on ^3He Filter

Think: NMR on the ^3He nuclei to invert preferred absorption



Cryogenic (Meissner screen)

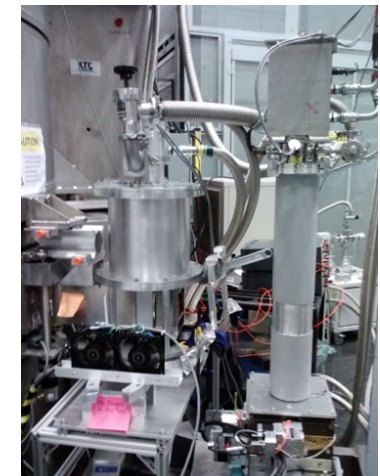
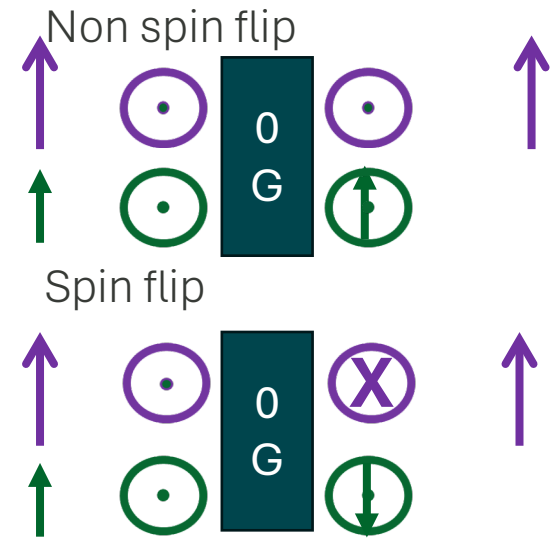

Depolarizers

Steel sheet: random polarized grains

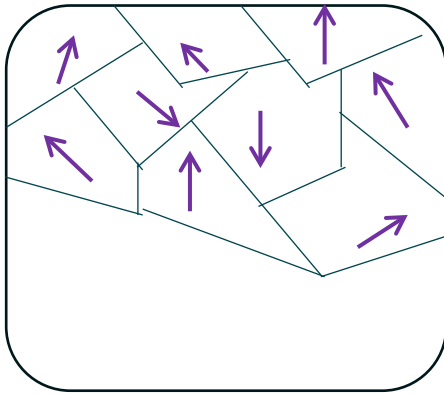

Each intergrain boundary represents a non-adiabatic transition for the neutron flying through

Can also be used as an order parameter measurement in powders. Depolarization as a function of temperature

Worst-Mezei-Flipper-Ever...

Aluminum wire, not anodized, not touching

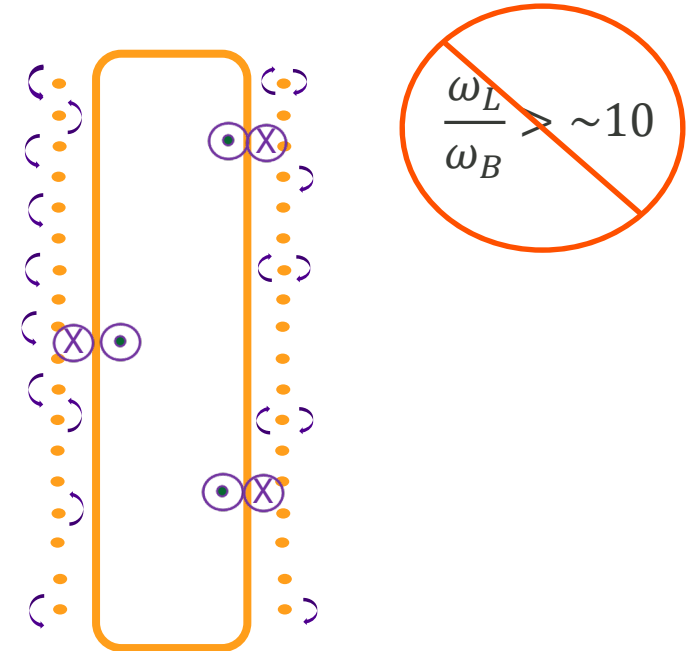

Zero field region

- *Instead of* preserving neutron moment direction with ‘guide field’ & Larmor precession
- Only way* to move beyond ‘spin-flip’ and ‘non-spin-flip’ for scattering at sample

Zero-field chamber established in part with μ -metal enclosure



Meissner (superconducting) barrier

- \vec{B} at interface is either \parallel surface or 0

One screen on this precession chamber couples with external guide field, & the opposite screen couples with zero-field chamber

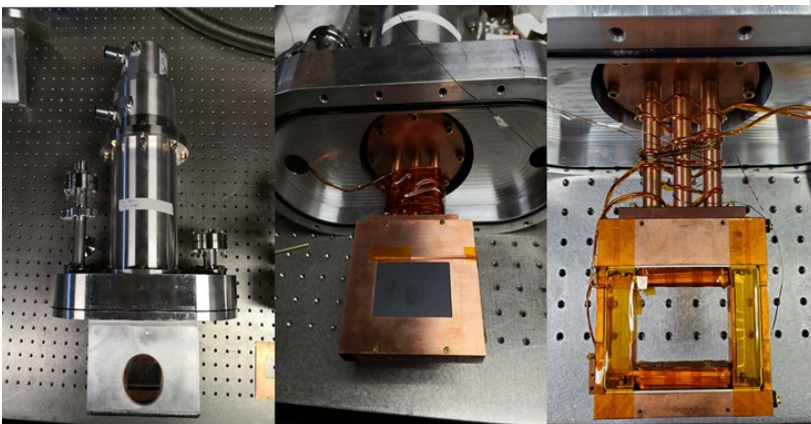

Precession chamber

Like Mezei flipper, but rotates to arbitrary angle, not just 180°

Coupled with nutator or another precession chamber, enables arbitrary orientation for neutron moment

- Established before sample
- Extracted after sample

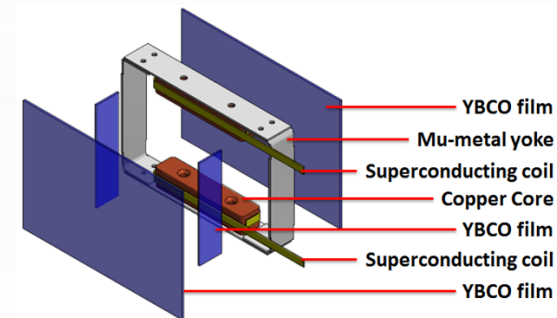

*Not entirely true. One published demonstration combined SNP & Larmor technique. Never repeated to my knowledge.
W. Schweika, “Time-of-flight and vector polarization analysis for diffuse neutron scattering” *Physica B* **335** 157 (2003)



Moving past the 'spin flip / non spin flip' paradigm

Spherical Neutron Polarimetry as special case

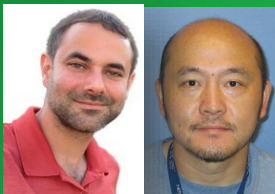

Sample region: Guide field vs Zero field, moving beyond the ‘spin-flip / non-spin-flip’ paradigm

Guide field

Preserves polarization via Larmor precession, for neutron moments either aligned (parallel) or anti-aligned (anti-parallel) to the magnetic guide field

Point the neutron moment in an arbitrary direction at the sample by pointing the guide field using 3D coils

Neutron reorientation during scatter at sample

Captures well spin-flip and non-spin-flip behaviors because the SAME guide field STILL preserves polarization

Spins out of control* when neutron moment reorientation $\neq 0^\circ$ or 180°

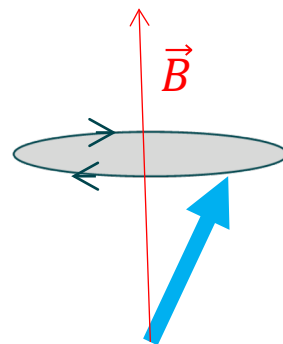

Zero field

Preserves polarization via DON'T TOUCH IT! Provide NO field to introduce NO Larmor precession

Point the neutron moment in an arbitrary direction at the sample by using neutron reorientation optics *before* the zero-field region to orient the neutron

Neutron reorientation during scatter at sample

Stays in ANY reoriented direction (not just 0° or 180°) while staying in the Zero field region

Captured well using neutron reorientation optics between the zero-field region and the scattered-beam polarization filter (called an ‘analyzer’)

Mezei flipper vs precession region

Mezei flipper

(same) Establish horizontal field using a coil and fixed current
although mean goes through solenoid-like coil

Abrupt change of field direction (non-adiabatic)

For fixed current works for SINGLE energy ONLY

(not same)

Aim for 0 or 180 rotation using current that's a function of E_i
for horizontal 'axis' solenoid-like coil in precession region

Second, vertical axis coil along beam path isolates guide field
upstream from flip field inside

Turn off BOTH coils when not flipping to regain vertical guide field

Downstream, neutron returns to guide field & 'gits dizzy'

Precession region

(same) Establish horizontal field using a coil and fixed current
although coils straddle beam

Abrupt change of field direction (non-adiabatic)

For fixed current works for SINGLE energy ONLY

(not same)

Aim for arbitrary rotation angle using continuous current range
for horizontal 'axis' coil/poles in precession region

Meissner shield along beam path isolates guide field
upstream from zero or flip field inside (and mu-metal shields
on top and sides finish the box)

Turn off flip coil/poles when not flipping to establish / extend zero field region

Downstream, neutron enters zero field region (upstream only)

ANY guide field MUST be \parallel Meissner shield surface at the interface...

Easier to establish a zero field on one end...

Spherical Polarimetry Configuration

many measurements

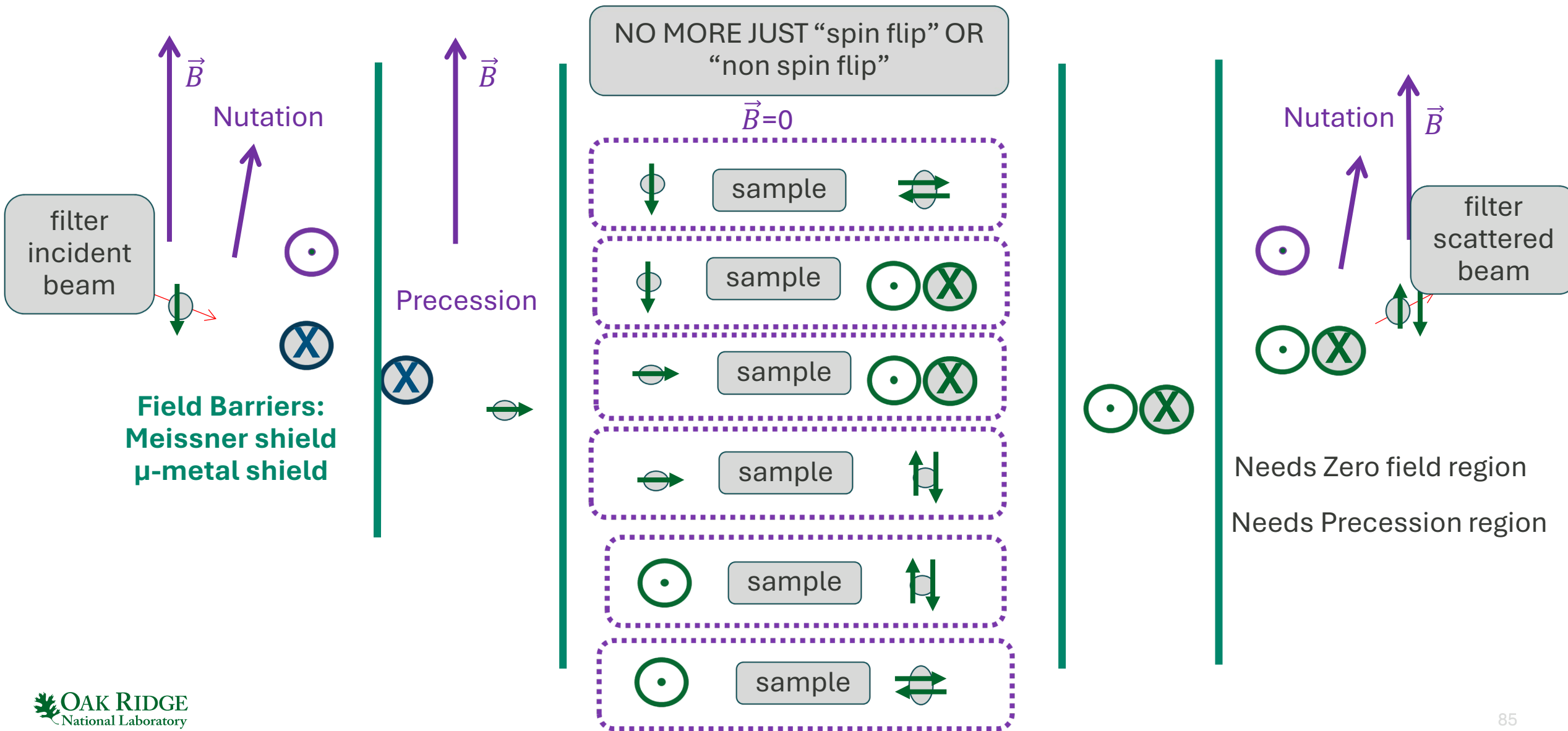

$S_{ab}(\vec{Q}, \omega)$ Full Magnetic Structure Factor Tensor

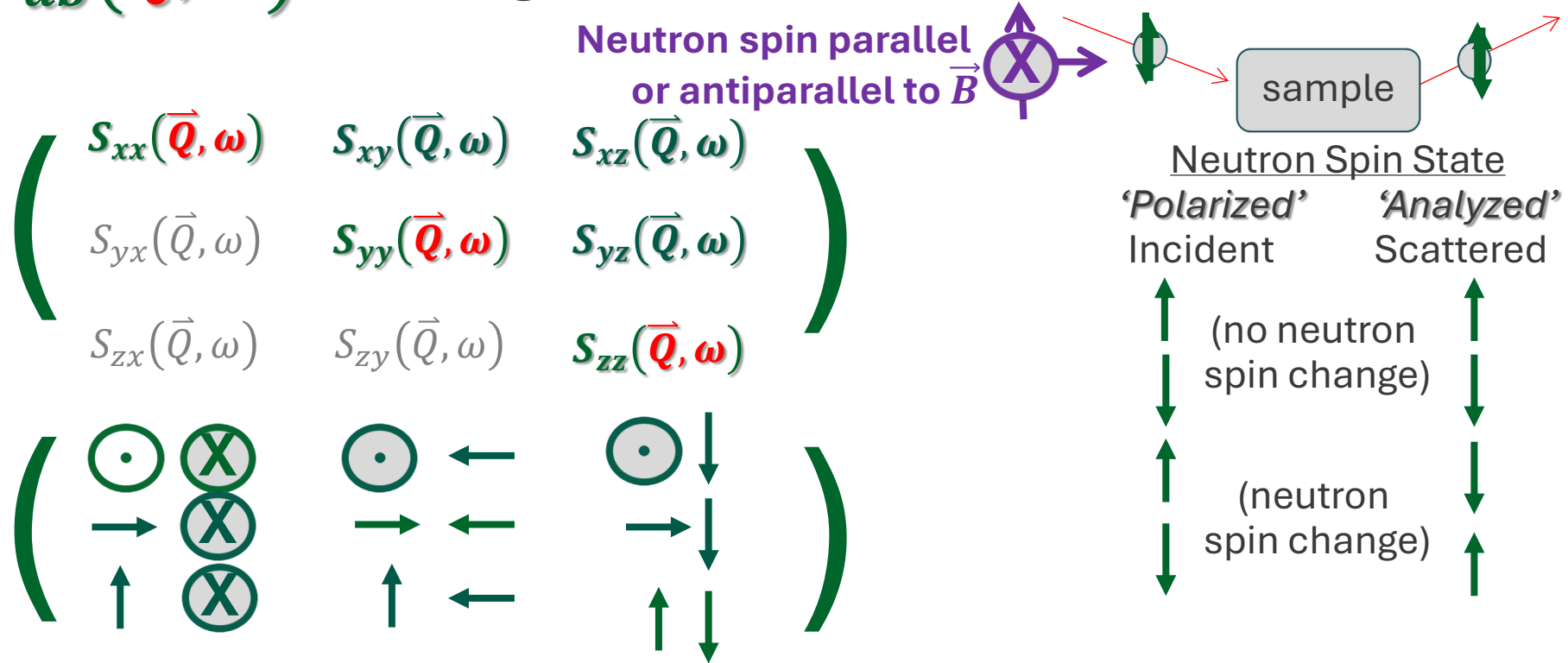

Off-Diagonal elements

needs 0 field at sample

Beyond Spin-Flip

Need for more exotic systems
(chiral, spin-lattice coupling¹)

Diagonal elements

Multiferroics

Antiferromagnets

Diffuse scattering

Tensor form, **but Orthogonal orientations, single final direction**

$$P_f = TP_i + P'$$

$$T\sigma = \begin{bmatrix} NN^* - \mathbf{M}_\perp \cdot \mathbf{M}_\perp^* & 2\text{Im}[NM_{\perp z}^*] & 2\text{Im}[NM_{\perp y}^*] \\ -2\text{Im}[NM_{\perp z}^*] & NN^* - \mathbf{M}_\perp \cdot \mathbf{M}_\perp^* + 2\text{Re}[M_{\perp y}M_{\perp y}^*] & 2\text{Re}[M_{\perp y}M_{\perp z}^*] \\ -2\text{Im}[NM_{\perp y}^*] & 2\text{Re}[M_{\perp z}M_{\perp y}^*] & NN^* - \mathbf{M}_\perp \cdot \mathbf{M}_\perp^* + 2\text{Re}[M_{\perp z}M_{\perp z}^*] \end{bmatrix}$$

$$P'\sigma = \begin{bmatrix} -2\text{Im}[M_{\perp y}M_{\perp z}^*] \\ 2\text{Re}[NM_{\perp y}^*] \\ 2\text{Re}[NM_{\perp z}^*] \end{bmatrix}$$

x along the direction of scattering vector \mathbf{Q} , z perpendicular to the scattering plane, y completes the Cartesian set

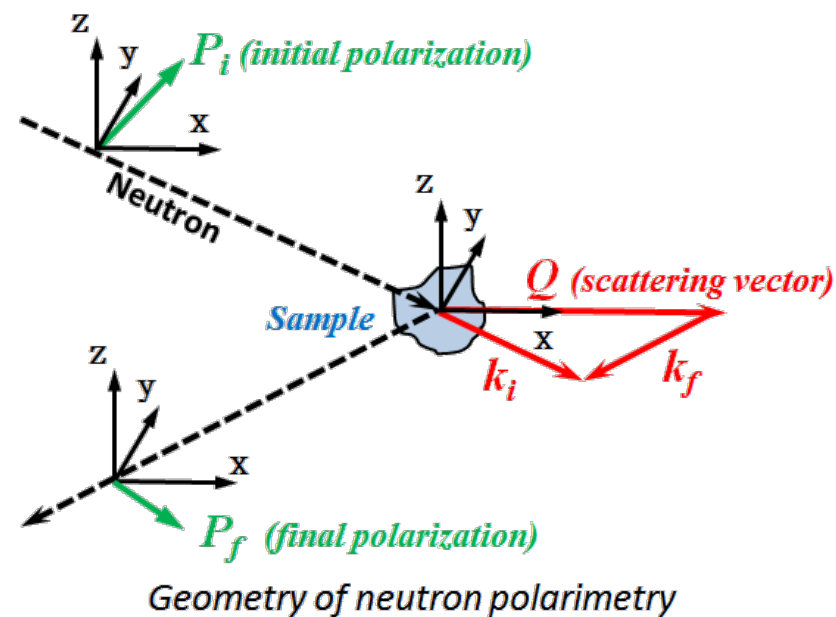

Spherical Polarimetry Capabilities

$$I = N^\dagger N + I_{si} + \underline{M_\perp^\dagger M_\perp} + \underline{P \cdot M_\perp^\dagger N} + \underline{P \cdot M_\perp N^\dagger} + i \underline{P \cdot (M_\perp^\dagger \times M_\perp)}$$

$$P^\dagger I = P \left(N^\dagger N - \frac{1}{3} I_{si} \right) + \underline{(P \cdot M_\perp^\dagger) M_\perp} + \underline{(P \cdot M_\perp) M_\perp^\dagger} - \underline{P (M_\perp^\dagger M_\perp)} + i N (P \times M_\perp^\dagger) - i N^\dagger (P \times M_\perp) + N M_\perp^\dagger + N^\dagger M_\perp - i (M_\perp^\dagger \times M_\perp)$$

- ★ Quantify magnetic moment and direction
- ★ Quantify 3D aspect of the coinciding of nuclear and magnetic coherent scattering in reciprocal space
- ★ Quantify magnitude and direction of chiral magnetic structure or dynamics
- ★ Insight into magnetic domains
- Best approach for polarization analysis of any superconducting sample of unusual shape



Polarization contrast, reality check

Low Transmission, Spectra

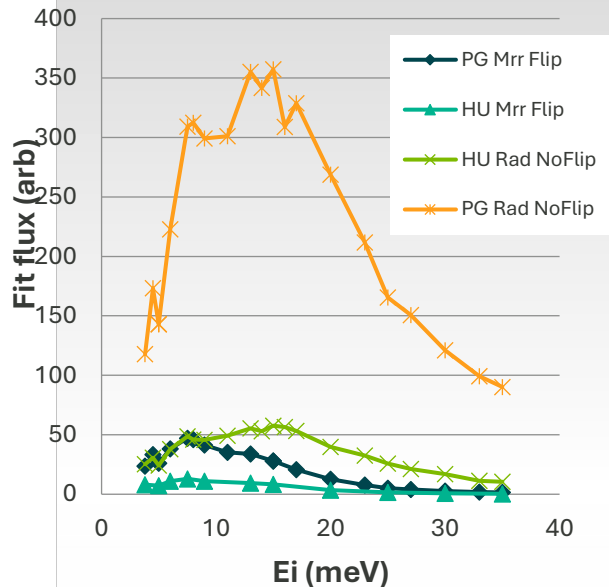

- Weak signal from low moment samples (for magnetism)
 - Try to minimize background to enhance S:N
 - Recover statistics via flux-resolution trade-off

Imperfect Polarization

- Polarization P

$$P = \frac{N^\uparrow - N^\downarrow}{N^\uparrow + N^\downarrow}$$

$$-1 < P < 1$$

- Flipping ratio F

$$F = \frac{N^\uparrow}{N^\downarrow}$$

- Due to imperfect
 - Filters
 - Guide fields
 - Modeling precession can help...
 - Flippers
 - Even *samples* can introduce depolarization effects

For many polarized neutron applications, you benefit from completing an unpolarized neutron scattering experiment in advance

Neutron beam trajectory & Sample conditions

- Not wide angle
- OK magnetized sample
- OK wide angle
- Not OK magnetized sample

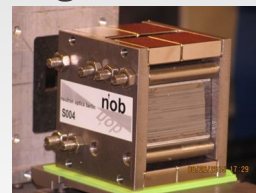

Thanks to NCNR for providing wide angle 'banana' 3He cell for ORNL

Many measurements

- $N \times$ measurements
 - Errors pile up
 - And with low transmission statistics can be bad to begin with...
- Recommend modeling to the measurement instead of working back to the model

Different polarization optics are compatible with different kinds of measurements

	Energy Range		Cross section / Divergence	Flipping Ratio	'Transmission'	Sample Compatibility	Environment Compatibility
	Simultaneous (meV)	Tunable (meV)					
Filters							
Heusler	~0.2 meV window	1-30 meV	~0.5°	8 to 20	~10%		
Supermirror	~15 meV (m choice)	1-20 meV	m & bend...	~100	~10%		
flat mirror							
C-bender							
S-bender							
V-channel							
Supermirror array wide angle			~60°				
3He	~20 meV	1-90 meV	~90°	8 to 20	varies by pressure & energy		Magnetic field uniformity requirements limit magnets
Retain polarization							
Guide fields	~20 meV (~10 Gauss)	(same)					limited uncompensated magnets
Nutators	~20 meV (~10 Gauss)	(same)	~60°				no ferromagnets
Zero Field Chambers	any	(same)				no ferromagnets	no magnets
Flippers							
Mezei	~0.2 meV window	1-30 meV	~3°	8 to 20			
Precession Coil	~0.2 meV window	1-30 meV	~3°	8 to 20			
RF flipper	~20 meV	1-30 meV	~6°	8 to 20			
AFP for 3He	~20 meV	1-90 meV	~90°	~100			
Cryo flipper	~20 meV (~10 Gauss)	1-90 meV	~60° (?)	8 to 20			preffered for uncompensated magnets
Drabkin flipper	~20 meV	1-90 meV	~3°	??			
Dabbs foil	~20 meV	1-90 meV	~60°	??			

When to not bother with polarized neutrons

Signal is clearly magnetic as shown by

- Cross section at lower Q is larger
- Temperature dependence

Magnetic signal is separated in reciprocal space from nuclear (phonon) signal

No interest in separating signals or in specific components of polarization tensor

Why not start with polarized neutrons?

Better to understand your sample with unpolarized neutrons first

- Indicator of whether polarized neutron scattering might make sense
- Polarized experiments are slower and have weaker signal
- Generally, more challenging to reduce (but getting better)



Active development and community

- Semi annual meetings / proceedings of PNCMI (Polarized Neutrons for Condensed Matter Investigations)
 - Proceedings from 2016:
<https://iopscience.iop.org/issue/1742-6596/862/1>
 - Proceedings from 2018:
<https://iopscience.iop.org/issue/1742-6596/1316/1>
 - Proceedings from 2022:
<https://iopscience.iop.org/issue/1742-6596/2481/1>
- Aspirations & new directions at ORNL & NCNR
 - Just ask!
- Actively building user community via training workshops (that's you, silly!)

For future reading

- Several dissertations
 - See instrument-specific publication lists
- Workshop slides, Polarization for Quantum Materials
 - Ovi, Masa, Yiqing & me, every other year
- Various online slide decks and tutorials
 - Ross Stuart,
http://www.oxfordneutronschool.org/2011/lectures/osns_stewart_polarised_2011.pdf
 - Kathryn Krycka, 'Neutron Polarization' slides & video at
<https://neutrons.ornl.gov/nxs/2021/lectures>
 - Werner Schweika, https://juser.fz-juelich.de/record/20415/files/C6_Schweika.pdf
- Books / chapters
 - Tapan Chatterji (ed.), *Neutron Scattering from Magnetic Materials* (2006) / several chapters
 - Stephen W Lovesey, *Theory of Neutron Scattering from Condensed Matter V2* (1984) / ch 10
 - G. Shirane, SM Shapiro, JM Tranquada, *Neutron Scattering with a Triple Axis Spectrometer* (2002) / ch 8
- Still great after 57 years!
 - Moon et al, <https://doi.org/10.1103/PhysRev.181.920>

Enhanced Resolution via
'Larmor' Techniques

Precession segway...

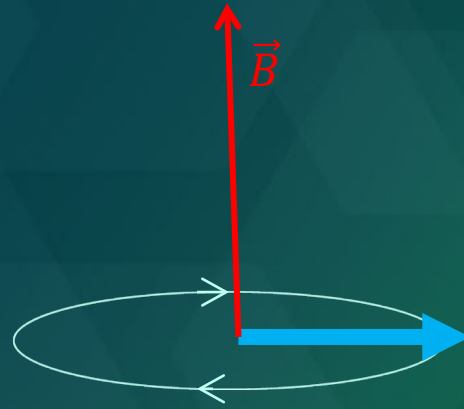

≠

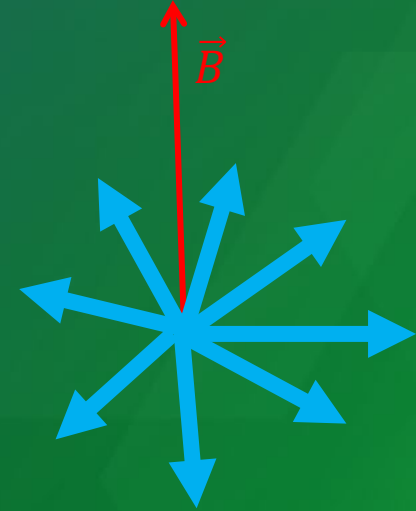

Known or measurable phase

Random, unknown phase

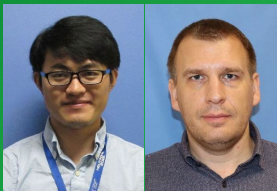

Enhanced Resolution via 'Larmor' Techniques

Enhances in only **One Direction**

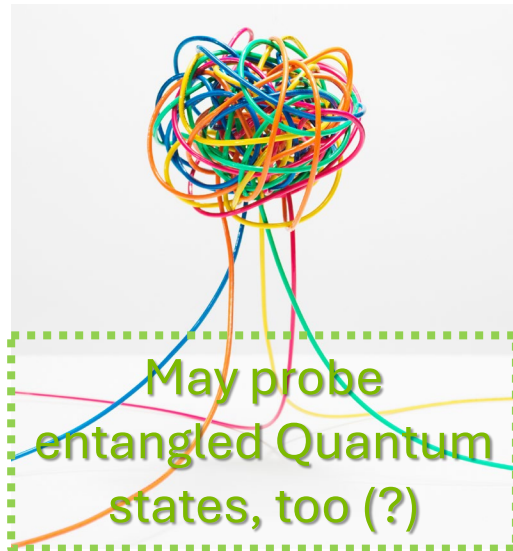

Neutron Spin Echo

ΔE or Δt enhancement

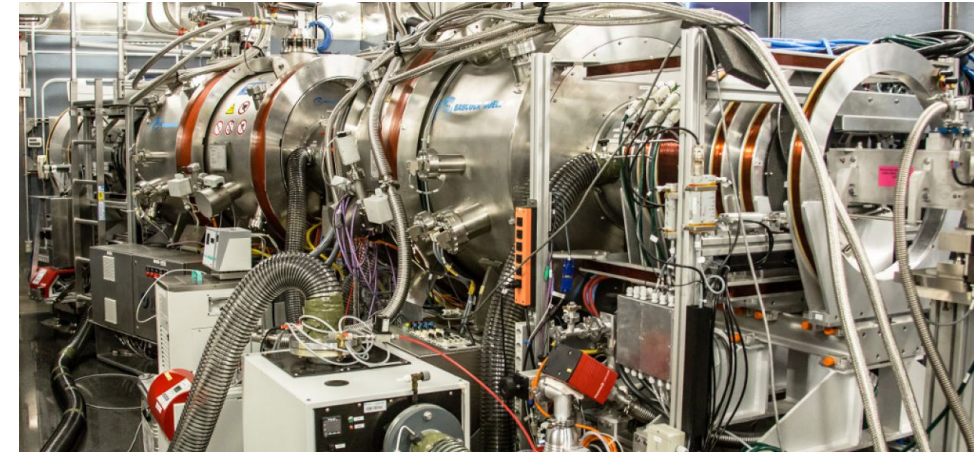

Wollaston Prism System

ΔQ or Δd enhancement

\perp to dispersion enhancement in $Q - E$ or 'reciprocal' space

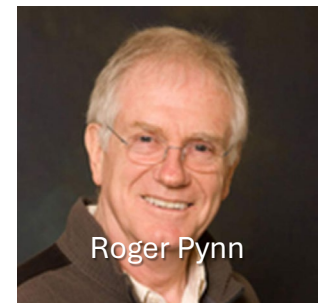
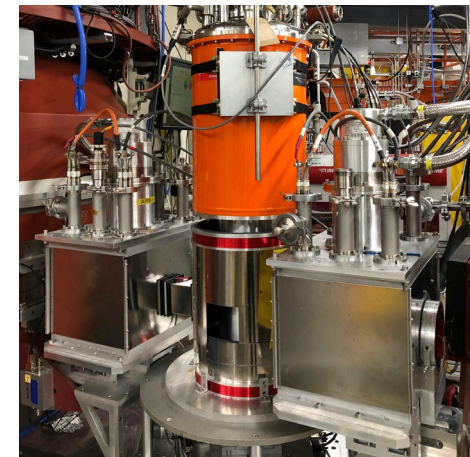



OAK RIDGE

National Laboratory



U.S. DEPARTMENT
of **ENERGY**

ORNL IS MANAGED BY UT-BATTELLE LLC
FOR THE US DEPARTMENT OF ENERGY