

Science opportunities using the neutron polarization analysis at the HYSPEC spectrometer

Ovidiu Garlea
*Neutron Scattering Division,
Oak Ridge National Laboratory*



ORNL spectroscopy suite

(viewgraph by B. Winn)

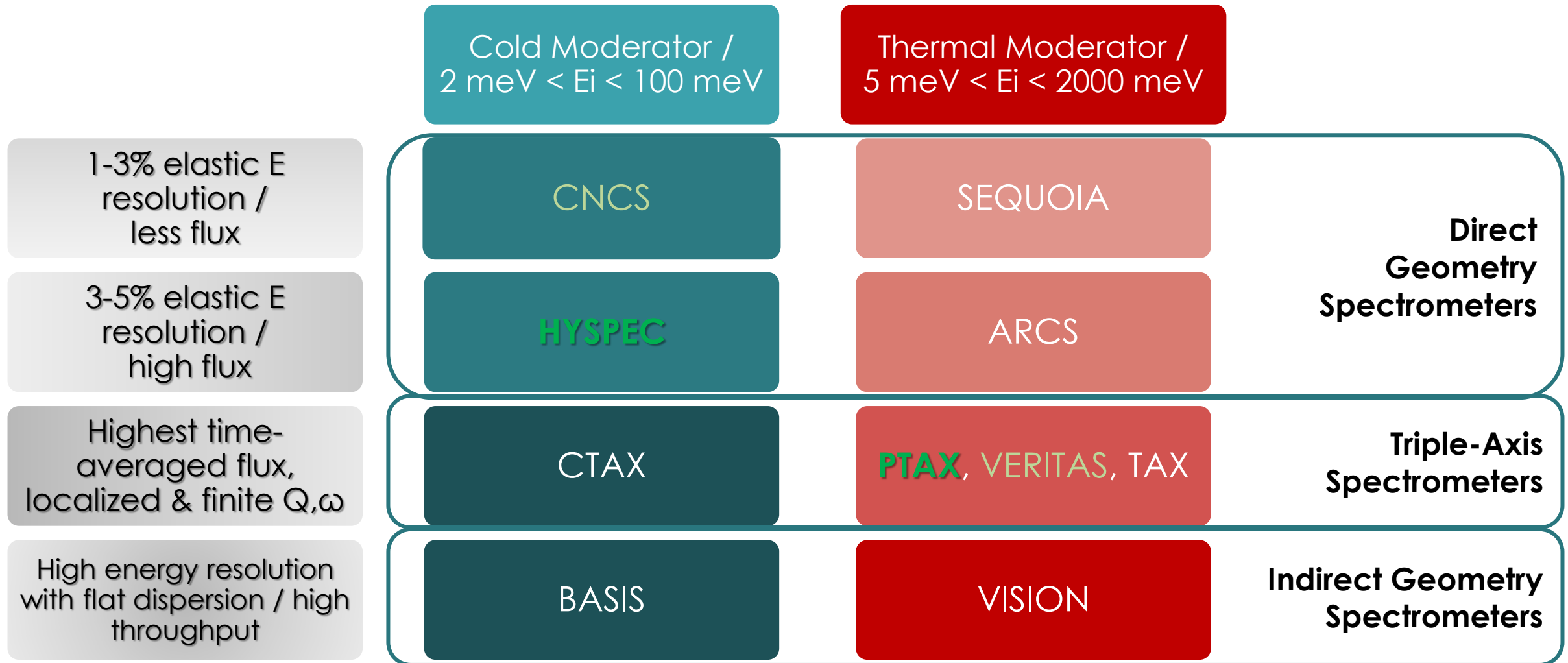

(Green: Supports Polarization Analysis)

HYSPEC: Hybrid Spectrometer

Barry Winn, Ovidiu Garlea, Colin Sarkis,
Melissa Graves-Brook (SA)

combines advantages of the TOF technique with those of 3-axis spectrometers:

- The incident neutron beam is monochromated using a Fermi chopper and is then focused onto the sample using Bragg optics.
- The energy spectrum of the scattered neutrons is measured via TOF

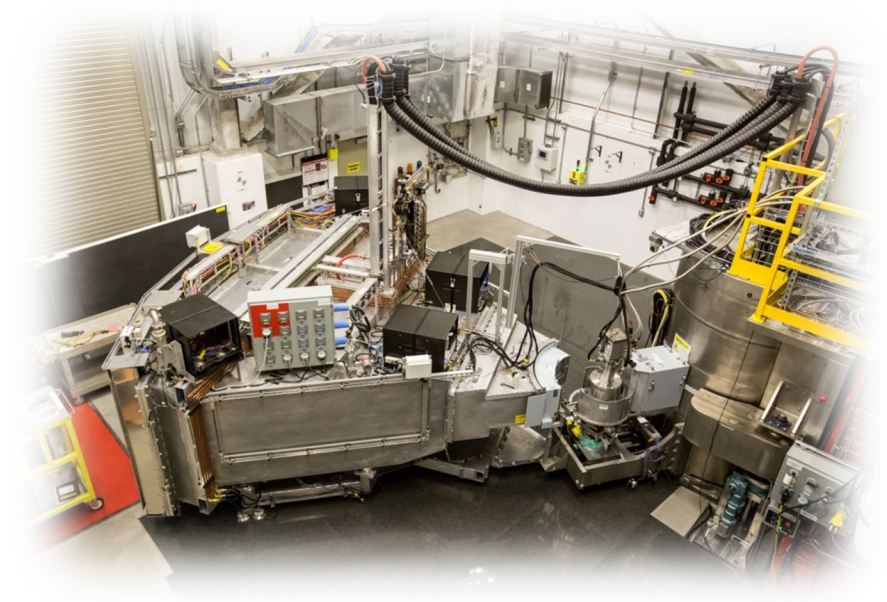

<http://neutrons.ornl.gov/hyspec/>

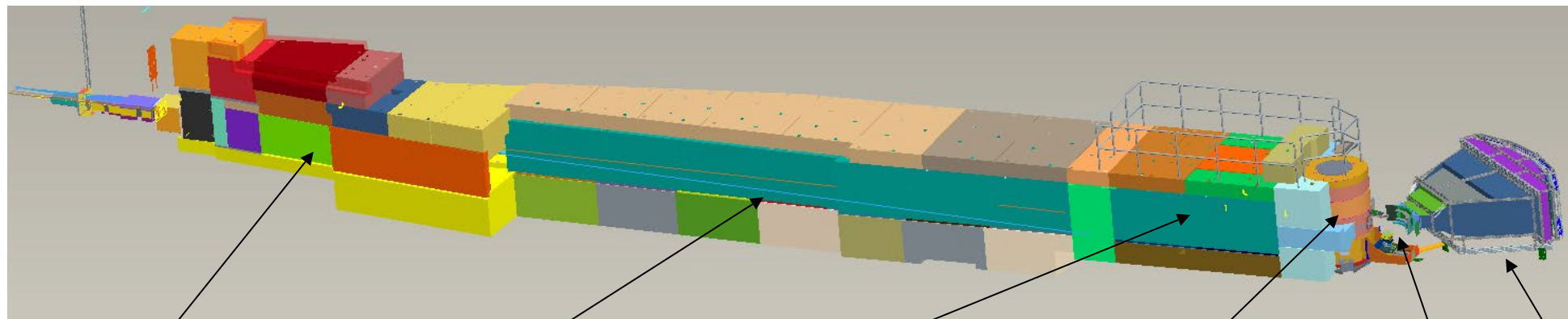

T0 chopper
T1a disk chopper

Curved Guide

T1b disk chopper
T2 Fermi chopper

Drum Shield &
Focusing Crystals

Sample

Detector
Vessel

HYSPEC: Unique aspects

- use of Bragg focusing optics
 - Increased flux at the sample position
 - Polarized or unpolarized incident beam (Cu₂MnAl Heusler(111) or PG(002) crystals)
- cold neutrons
 - 3.8 meV < E_i < 60 meV unpolarized
 - 3.8 meV < E_i < 25 meV polarized
 - energy resolution: 3-5% E_i
- movable bank of position-sensitive detector tubes
60° (horizontal) , ± 7° (vertical)
positioned over 3° < 2Theta < 110°
- uses a full range of ancillary sample environments

<https://neutrons.ornl.gov/sample>



- rapid switching between polarized and unpolarized operation

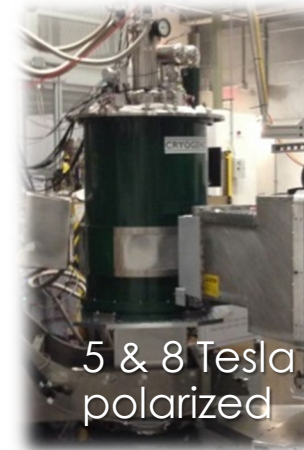

Typical measurements using single-crystals at HYSPEC

Sample is rotated about its vertical axis to fill up the scattering volume

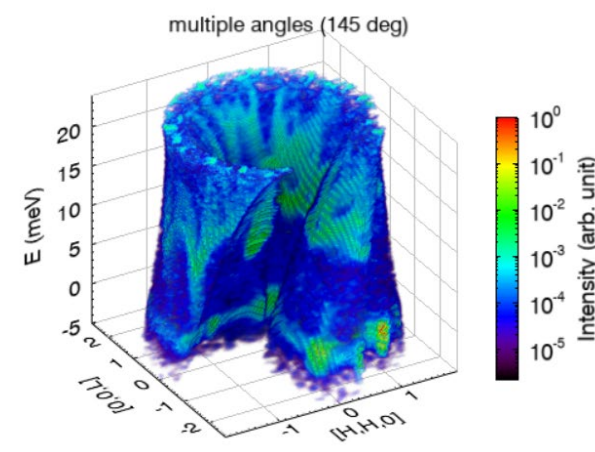
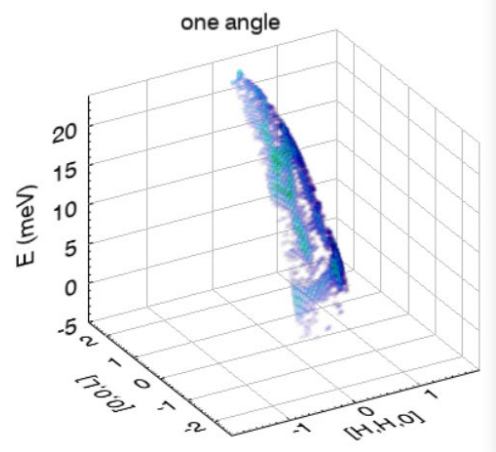
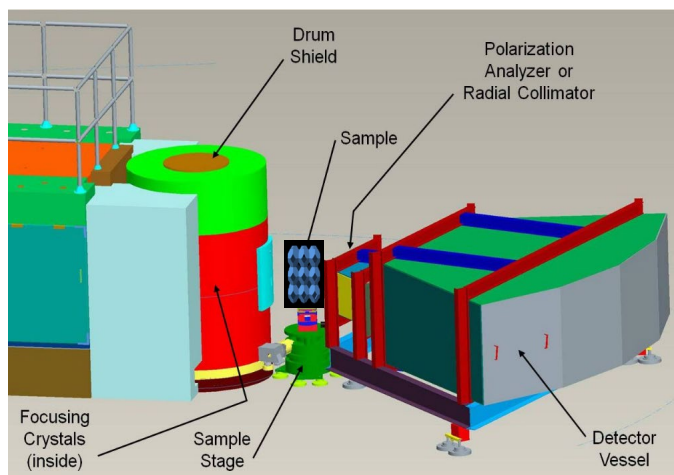
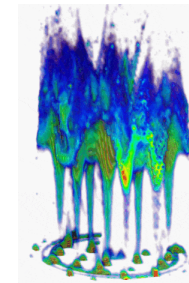

Q slices for various energy transfer $\Delta E=1$ meV

Q-L slices for various HH positions

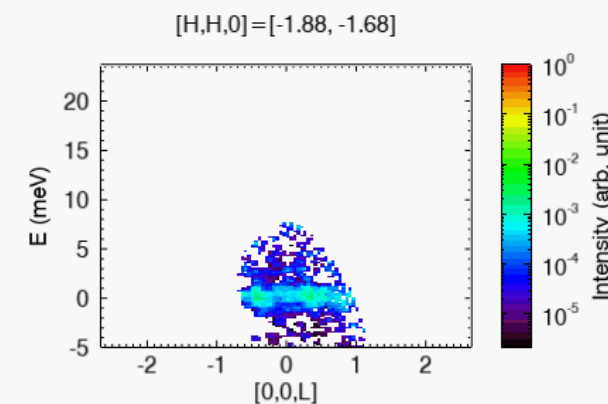
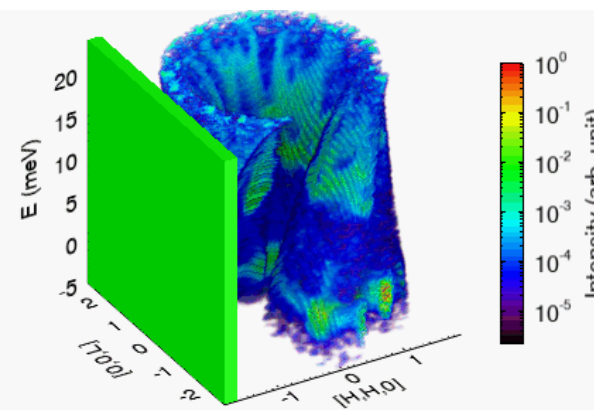
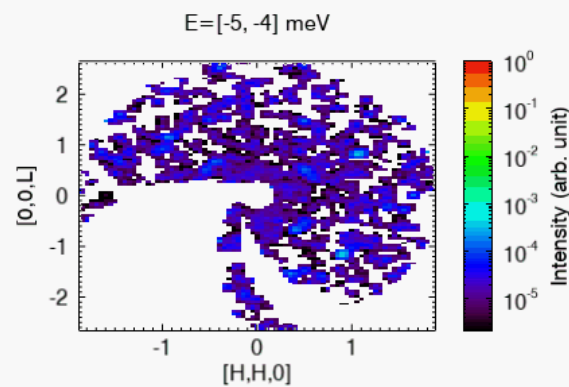
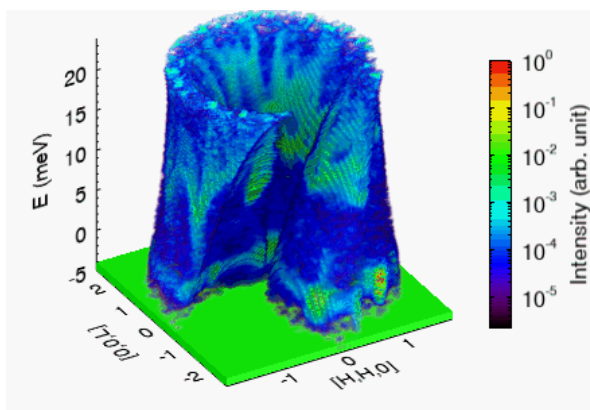

HYSPEC polarization main components

Polarizer:
Heusler (Cu₂MnAl)
focusing array



$$I^{\pm} = (F_N \pm F_M)^2$$

For (111) reflection
of Cu₂MnAl:

$$F_N \approx F_M \rightarrow$$

$$I^+ = 4 F_N^2, \text{ \& } I^+ \approx 0$$

$$P_0 = (I^+ - I^-) / (I^+ + I^-)$$

Guide Field: a permanent
magnet yoke assembly inside
the exit port of the drum shield

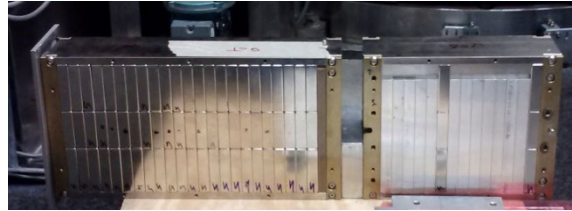

Guide Field: Optic-rail
mounted variable-strength
magnet yoke assemblies

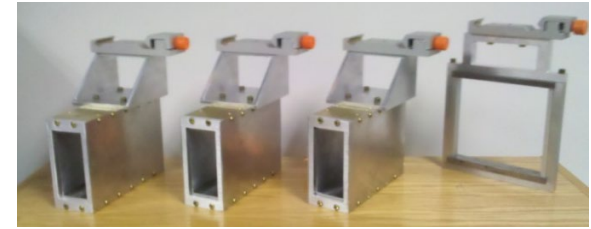

Mezei Flipper

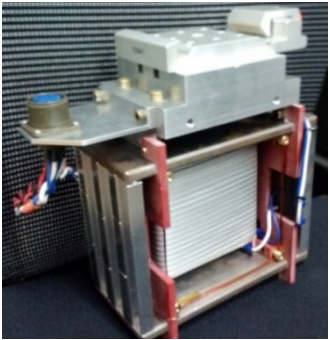

XYZ-Guide Field coils
(< 50 G at sample)

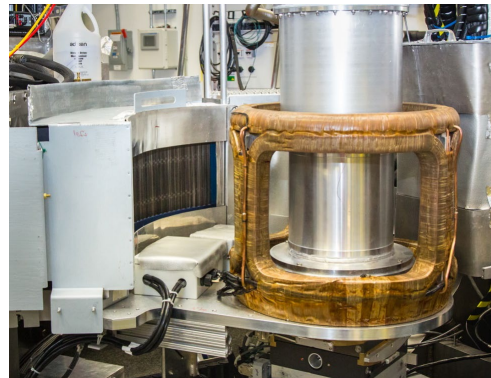

Supermirror Analyzer (P_{eff} ~94%)

60deg / 960 FeCoV-based supermirrors
made at Paul-Scherrer Institut (PSI)

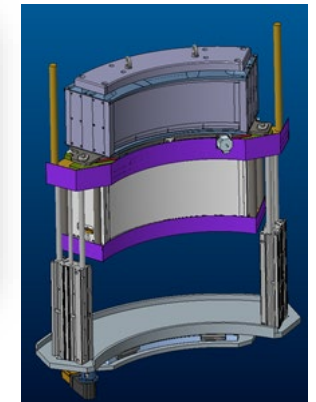

Elevator system & Oscillator:
improves the operational flexibility

HYSPEC: Polarization Performance

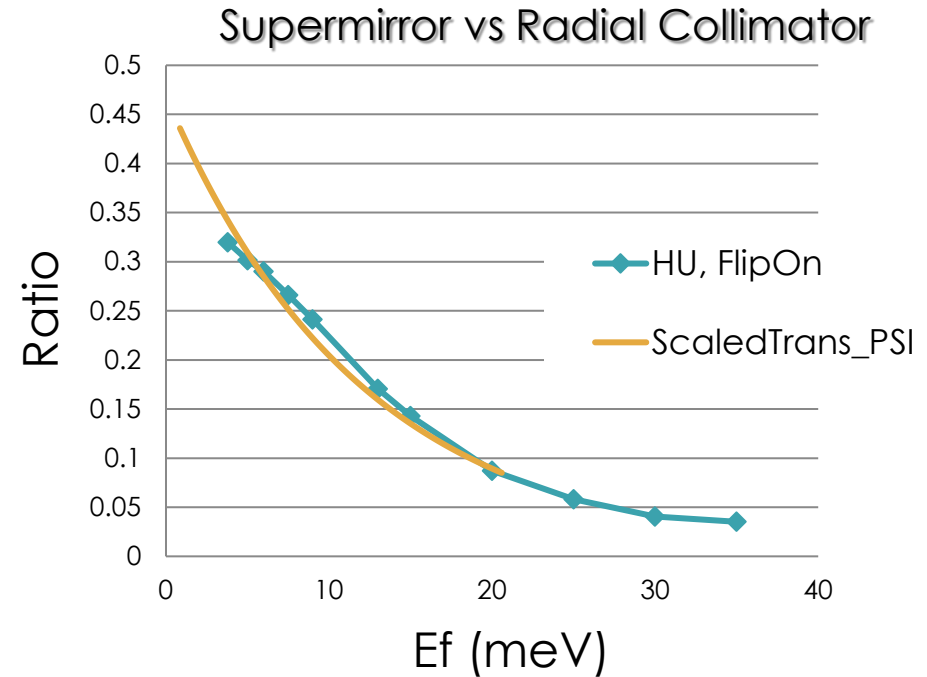
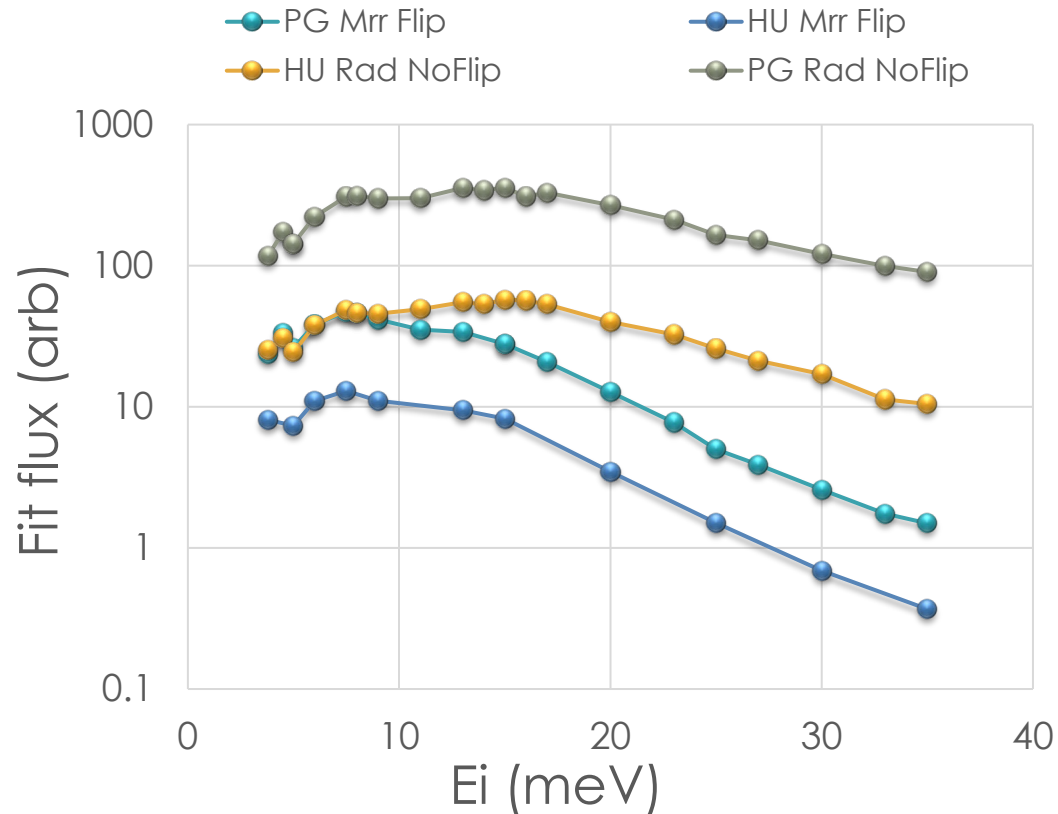

Given the increased experimental complexity, thorough characterization with an unpolarized beam is imperative

Exponential-like dependence of transmission in energy $I = I_0 e^{-\lambda E_F}$

HYSPEC: Polarization Performance

- Curved mirrors → Deflection of scattering ~ 1.8 deg
- The supermirror gives enhanced collimation → Scattered intensity sensitive to sample size and position
- The transmission depends on position and energy

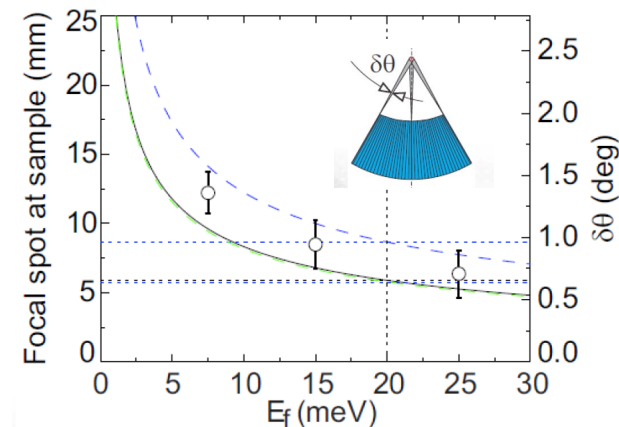

Radial collimator

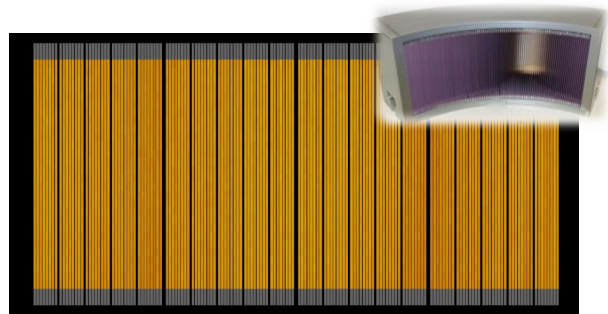

Supermirror analyzer

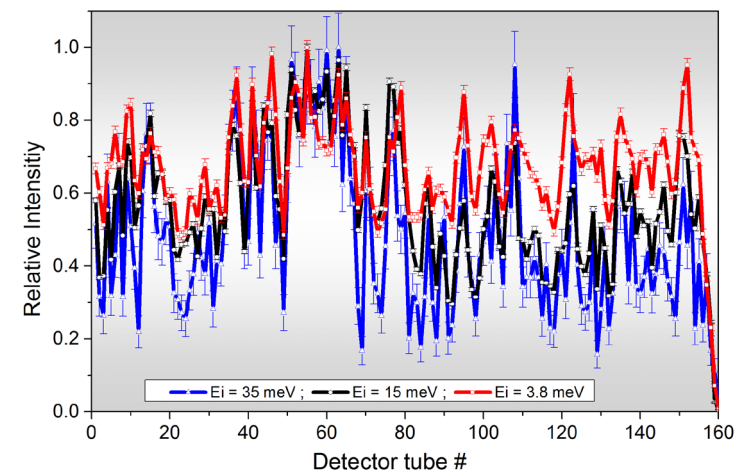
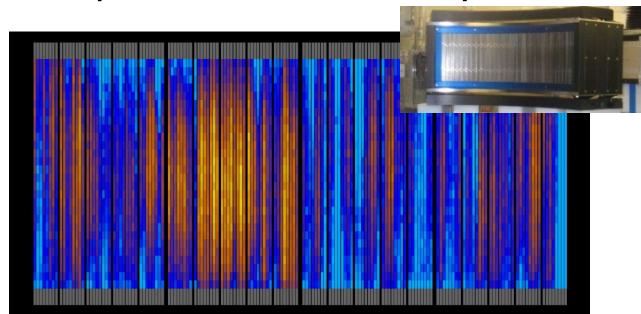

Workflow for reducing HYSPEC data (Mantid) (A. Savici)

- Corrects geometry for beam deflection through supermirror and for angular and energy dependence of transmission

- Also corrects for flipping ratio : $SF_{corr} = \frac{F}{F-1} SF + \frac{1}{F-1} NSF$

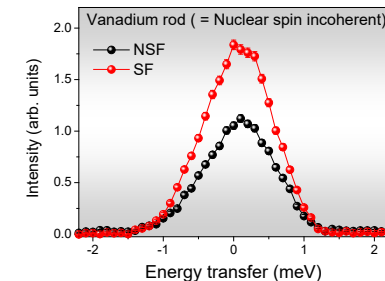
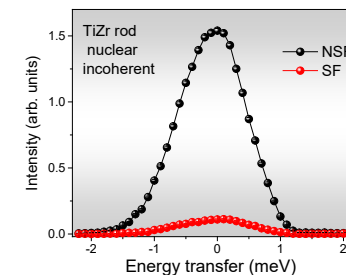

I. Zaliznyak *et. al* J. Phys.: Conf. Series 862, 012030 (2017)

Half – Polarization studies at HYSPEC Spectrometer

Used for studies of static spin ordering and dynamics in ferro, ferrimagnets and altermagnets

$$I_{z0} - I_{\bar{z}0} = 2P(NM_{\perp z}^* + N^*M_{\perp z})$$

$$I_{x0} - I_{\bar{x}0} = M_{\perp z}M_{\perp y}^* - M_{\perp y}M_{\perp z}^*$$

Vertical compensated
5 T asymmetric or 8T
symmetric cryomagnets

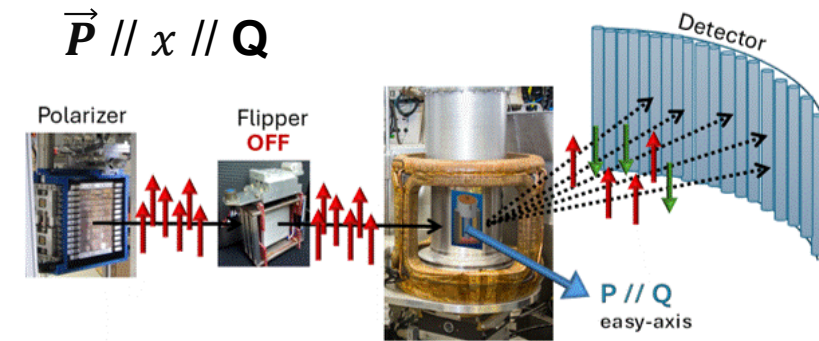
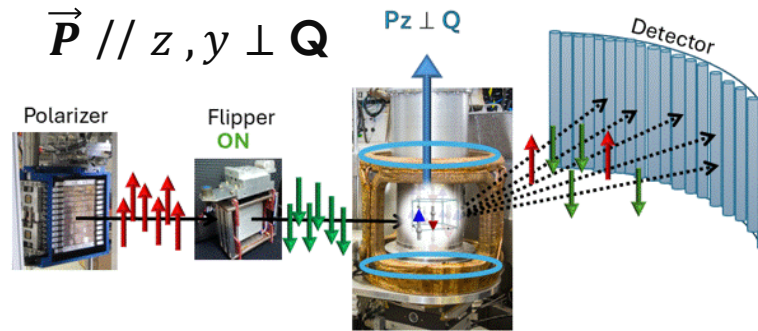

Permanent magnet
vertical field yokes (~ 0.5 T)

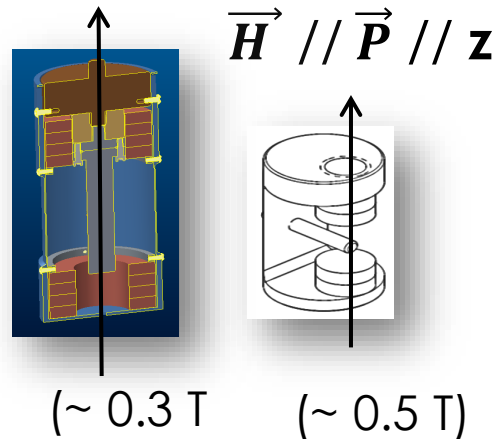

Horizontal field
yoke (~ 0.3 T)

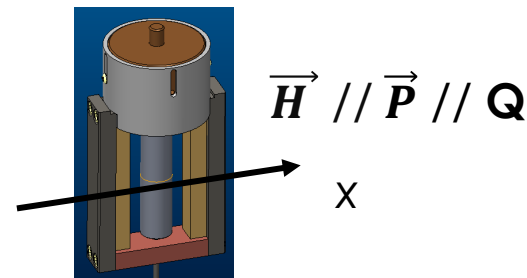

3D coil (~ 50 Gauss)
(any field direction)

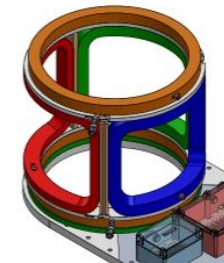

Science highlights: Half-Polarized experiments

enhanced sensitivity from the nuclear-magnetic interference term $F_N F_M$

$$I_{z0} - I_{\bar{z}0} = 2P(NM_{\perp z}^* + N^*M_{\perp z})$$

- **Reentrant spin glass state induced by structural phase transition in $\text{La}_{0.4}\text{Ce}_{0.6}\text{Co}_2\text{P}_2$**

J. K. Clark et al., Phys. Rev. Matt 4, 074412 (2020)

- Measure weak 0.15(1) m_B per Co atom
- Gradual dissipation of a weak FM ordering and onset of a glassy state



- **Probing the multiple magnetic ordered states in $\text{Nd}_2\text{Co}_{12}\text{As}_7$**
- X. Tan, J. Solid State Chem. 236, 147 (2016)*
- $P \parallel z$ - Co moment are different for the two sites: $\mu(\text{Co}_1) = 0.10(5) \mu_B$ and $\mu(\text{Co}_2) = 0.3(1) \mu_B$.

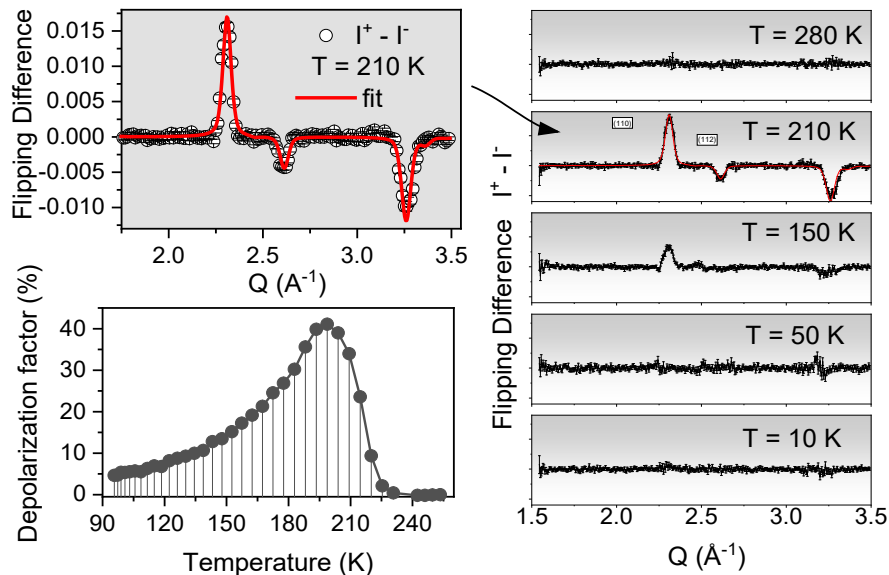

- Depolarization is a highly effective order parameter probe

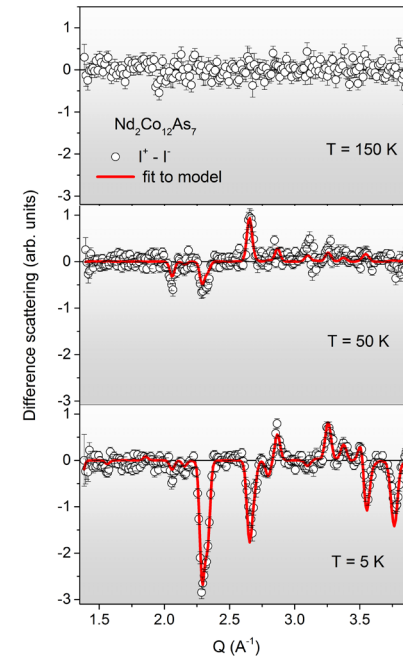

- Ordering of Nd moments antiparallel to the Co moments at 5 K.

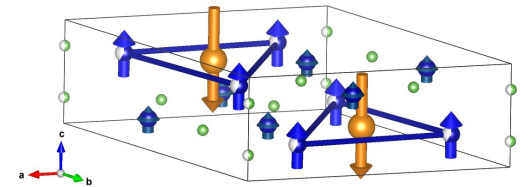

Observation of Magnons in Ferromagnets

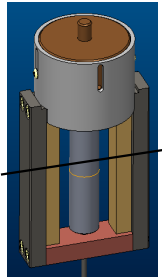

P // Q

No analyzer needed
("Half-Polarization")

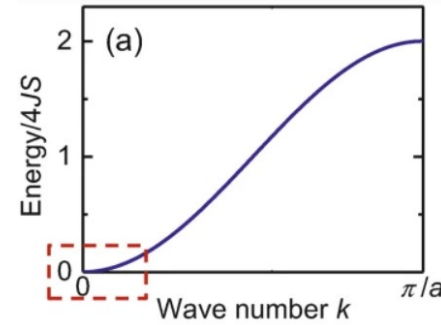
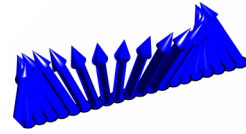

$$\omega_k = \gamma \mu_0 (H_z + D k^2)$$

$$\Delta I_x = I_x^{+0} - I_x^{-0} = I_x^{+-} - I_x^{-+} = M_{\perp z} M_{\perp y}^* - M_{\perp y} M_{\perp z}^*$$

(+ -) → magnon creation (energy loss, $\Delta E > 0$)

(- +) → magnon annihilation (energy gain)

R. M. Moon, T. Riste, and W. C. Koehler,
Phys. Rev. 181, 920 (1969)

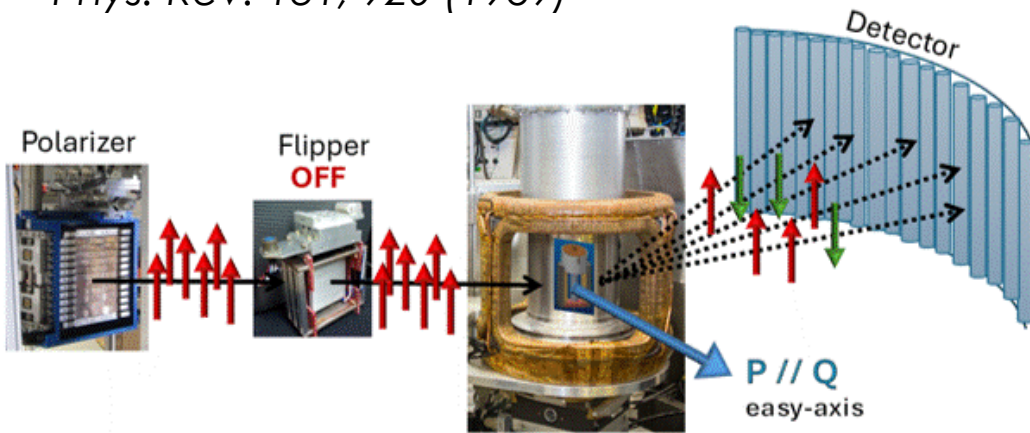

Magnon annihilation / creation using isotopic single crystal ^{160}Gd

Granroth et al.

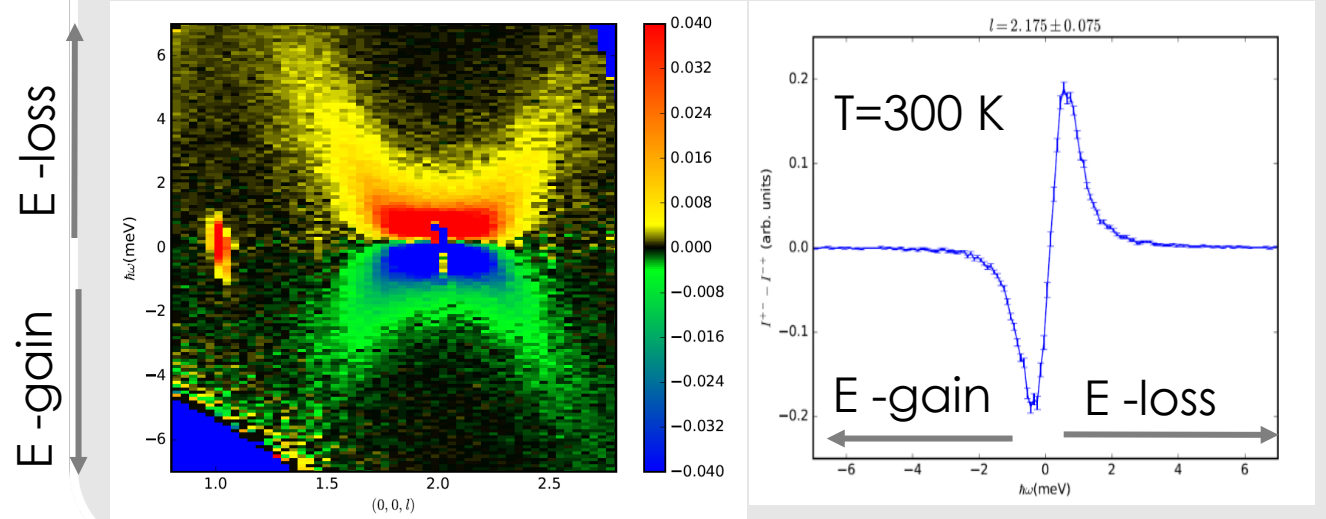

Observation of Magnon Polarization in Ferrimagnets

“Half-Polarization” (no polarization analysis)

$$\Delta I_x = I_x^{+0} - I_x^{-0} = I_x^{+-} - I_x^{-+} = M_{\perp z} M_{\perp y}^* - M_{\perp y} M_{\perp z}^*$$

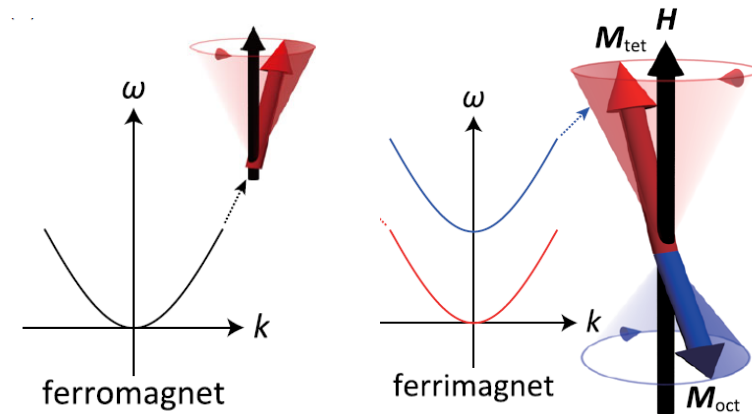
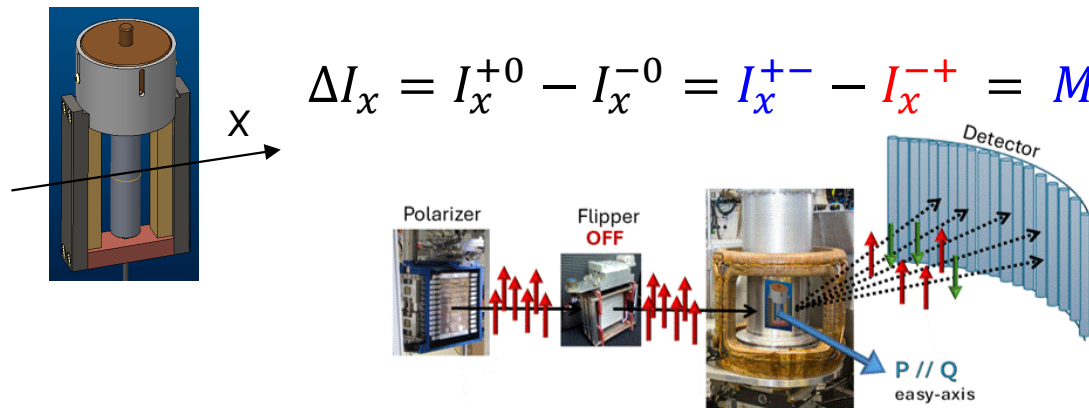

Ferrimagnets : magnons with opposite polarization into acoustic and optical modes
 Y. Nambu *et. al.*, PRL, 125, 2, 027201 (2020)

Magnon Polarization in $Y_3Fe_5O_{12}$ garnet (YIG)

Observation of both signs of magnon polarization giving direct proof of ferrimagnetic nature

Y. Nambu *et. al.*, Phys. Rev. Lett., 125, 2, 027201 (2020)

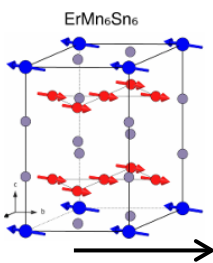
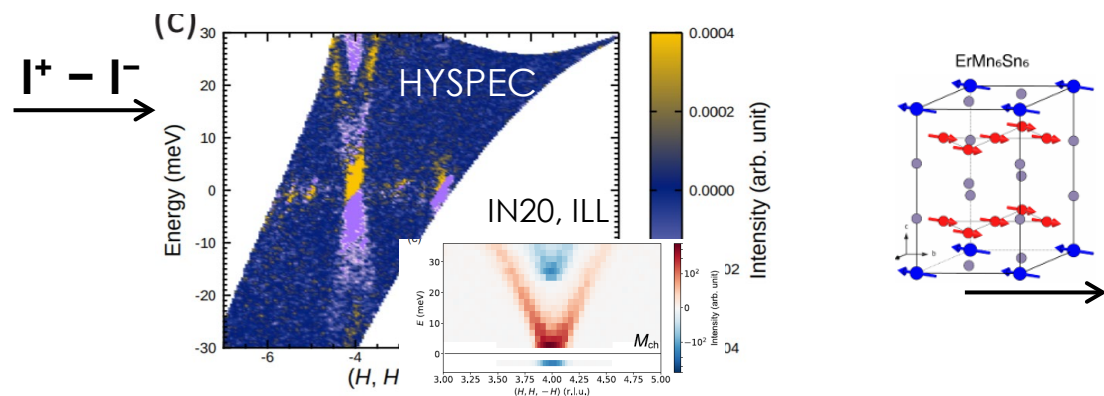

Mixing of magnons chirality in $ErMn_6Sn_6$ ferrimagnet

Dhurba R. Jaishi, R. J. McQueeney, *et. al.*, PRL

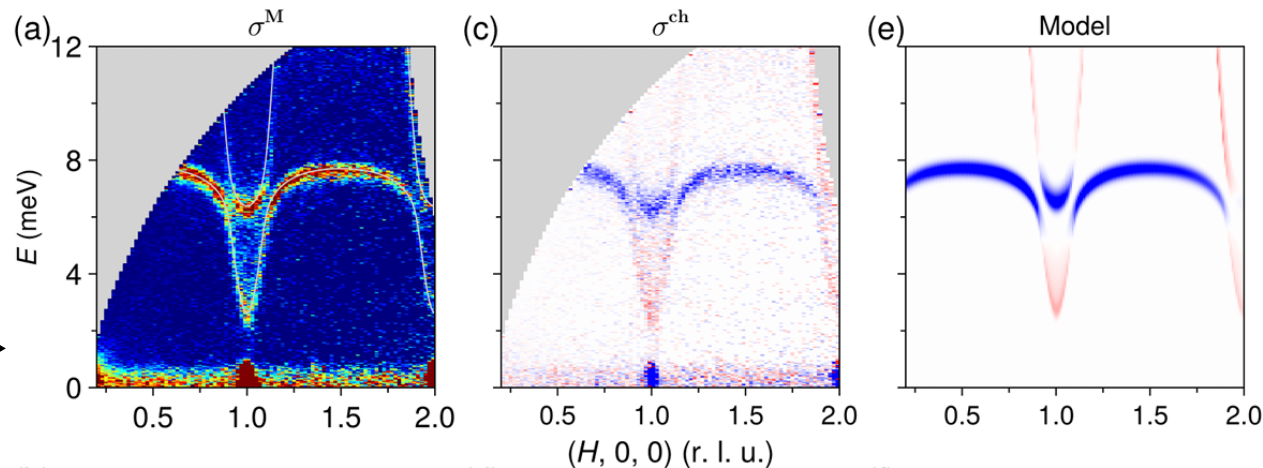

Polarized INS provides a clear test of whether a crystal is an altermagnet

Antiferromagnetism
proposed by Néel (1930s)
confirmed by neutron (Shull, 1950s)

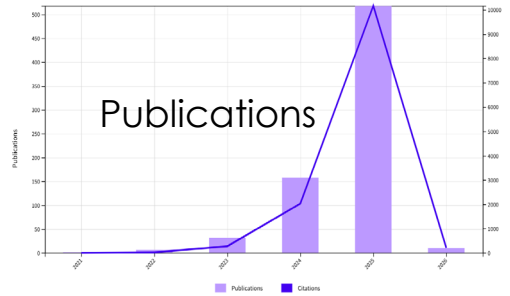
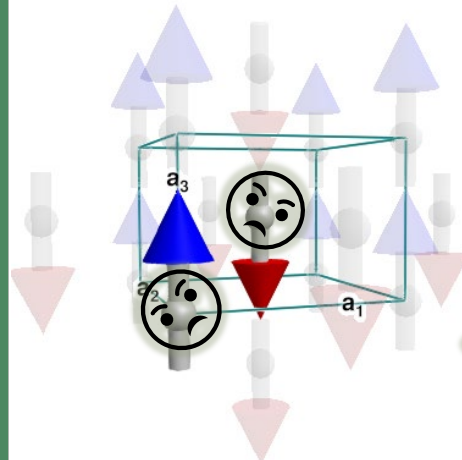

Altermagnetism

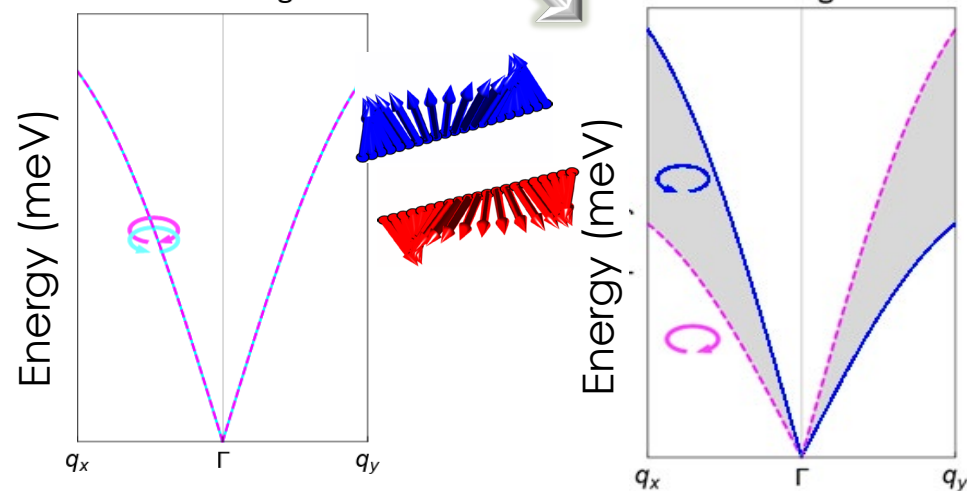

Step 1: Find evidence of the spin-wave splitting with unpolarized neutrons

- ✓ Theoretical prediction of splitting in momentum-energy space
→ informs experiment setup

MnF₂ and FeF₂ crystals oriented in (HHL)

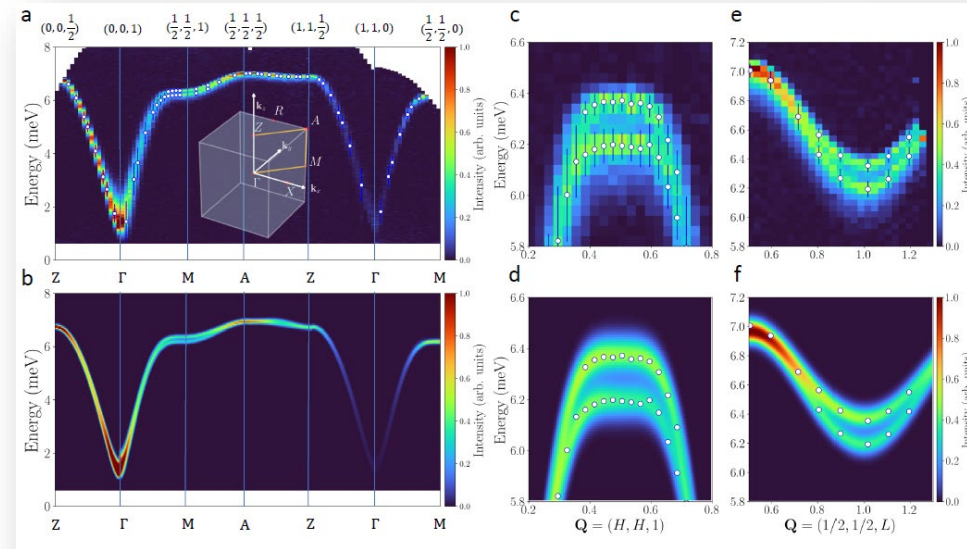
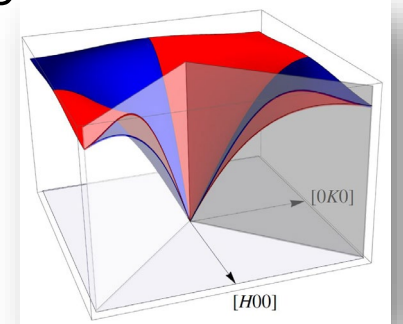

ΔE split $\sim 178(3)\mu\text{eV}$



MnF₂: Q. Faure *et al.*, arXiv.2509.07087

FeF₂: J. Sears *et al.*, arXiv:2601.04303v

Polarized INS provides a clear test of whether a crystal is an altermagnet

Step 2: Determine the relative magnetic domain populations using Polarized Neutron Diffraction setting

Half-Polarization with $P // z$
(exploits the nuclear-magnetic $N^* \vec{M}_\perp$ interference term)

$$R = \frac{I^+}{I^-} = \frac{1 + P_i(2\alpha - 1)}{1 - P_i\epsilon(2\alpha - 1)}$$

α = domain fraction

Q. Faure et al, arXiv.2509.07087



Domain 1

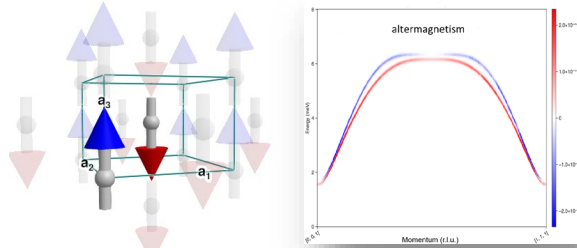

Domain 2

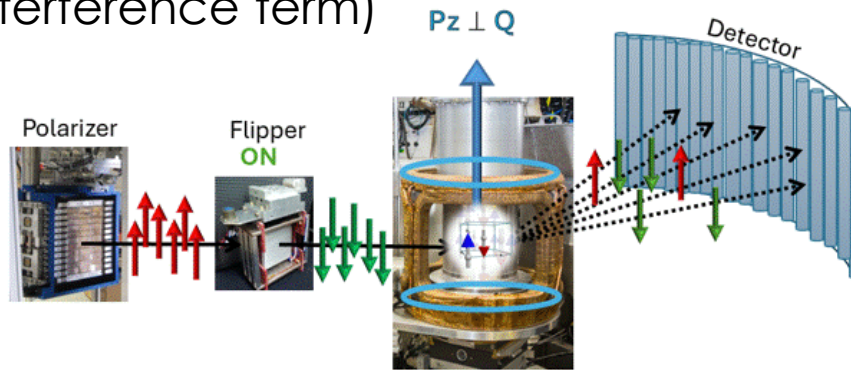
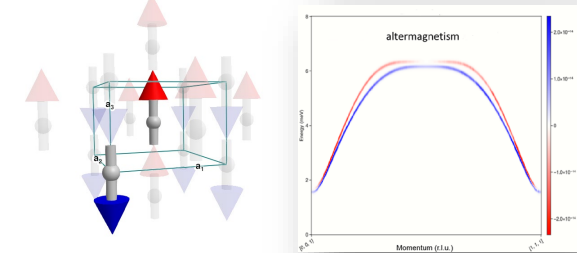

- ✓ Flipping ratio measurements on (2,1,0) and (2,-1,0) reflections where $F_N \approx F_M$
- ✓ Screening of multiple MnF_2 crystals to select the one with the best naturally occurring domain ratio of 82% (D1) and 18% (D2)

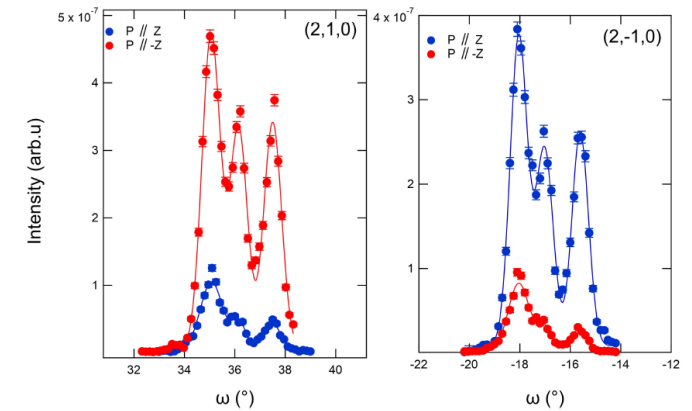

! Chirality cannot be detected when the magnetic domains are equally populated

- ✓ If an unbalanced domain population does not arise naturally from microstructural effects, field cooling or the application of uniaxial pressure may be required

Polarized INS provides a clear test of whether a crystal is an altermagnet

Step 3: Half Polarization $P \parallel Q$ and $-Q$, inside horizontal plane

$$I_x^{+0} - I_x^{-0} = M_{\perp y} M_{\perp z}^* - M_{\perp z} M_{\perp y}^*$$

Magnon chirality in MnF_2

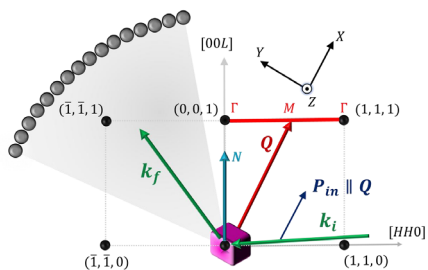
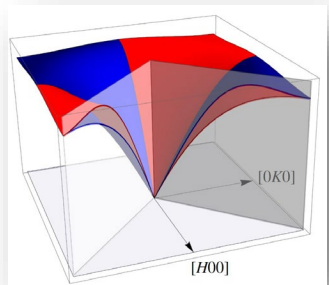

Optimized $P \parallel Q$ condition (Q,E)

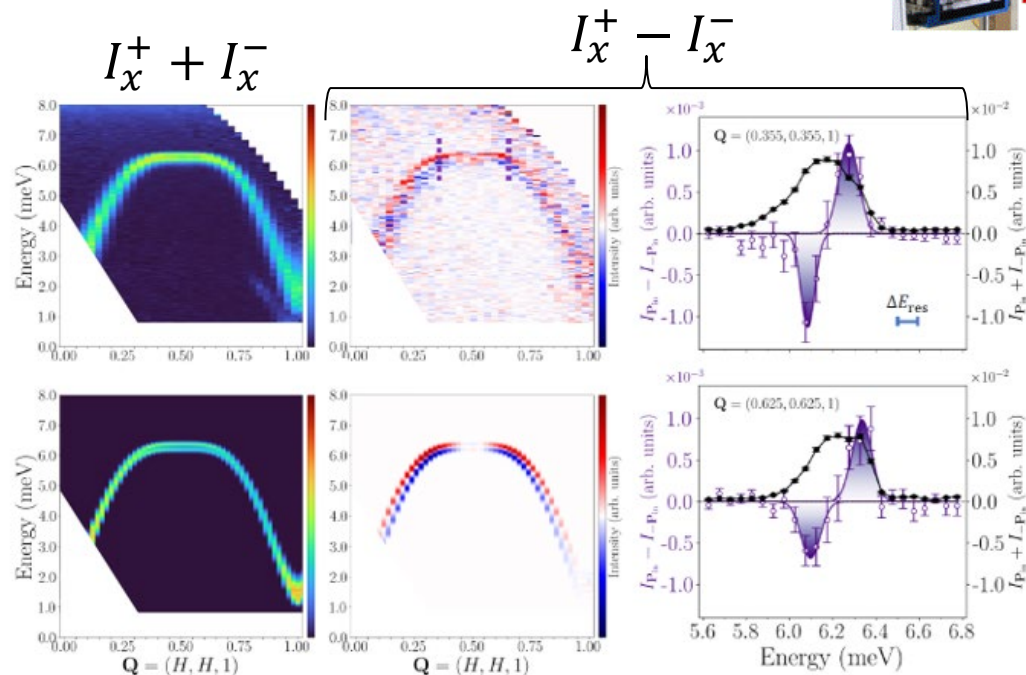
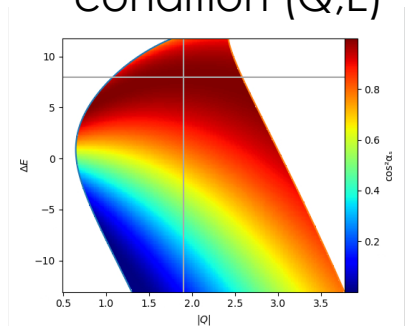

Altermagnetism revealed by polarized neutrons in MnF_2

Quentin Faure^{1†}, Dalila Bououa^{1†}, Victor Balédent^{2,3†}, Arsen Gukasov¹, V. Ovidiu Garlea⁴, Afonso Ribeiro¹, Jeffrey G. Rau⁵, Sylvain Petit¹, Paul McClarty¹.

arXiv.2509.07087

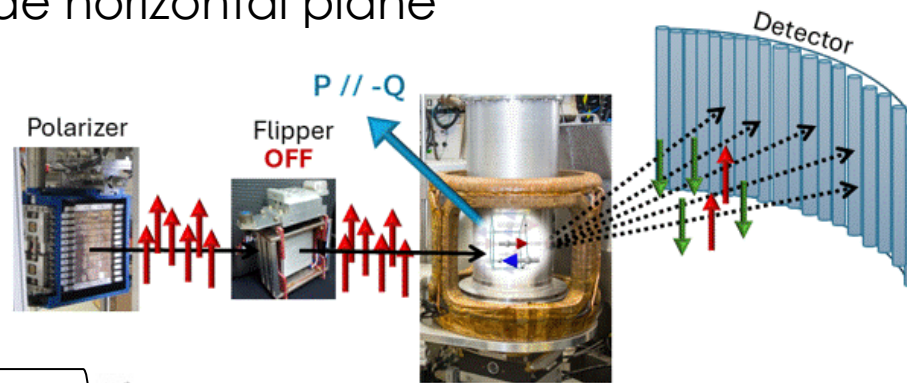
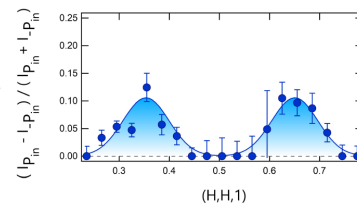

Magnon chirality in $MnTe$

T. Masuda et al (PRL -under review)

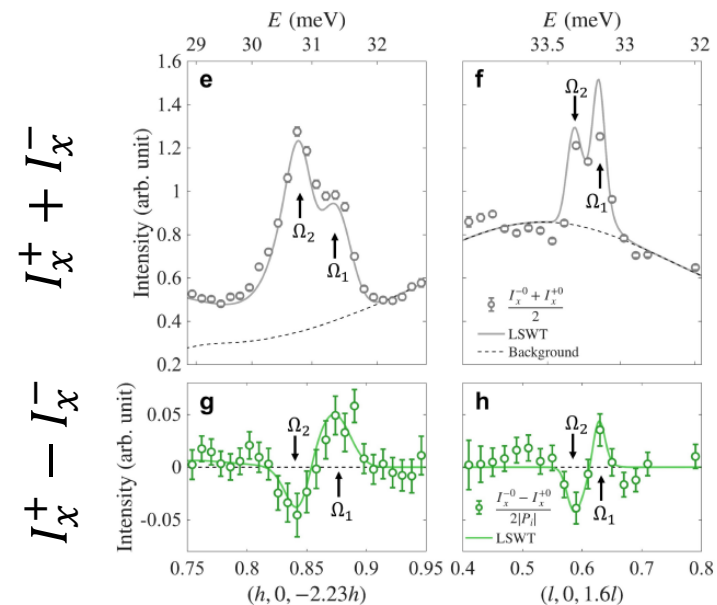

XYZ polarization analysis at HYSPEC

Spin Flip (SF), ($\uparrow \downarrow$)

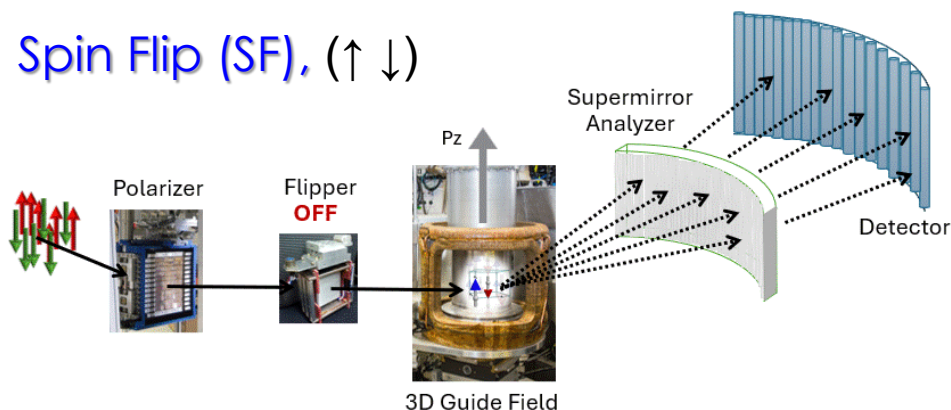

Non Spin Flip (NSF), ($\uparrow \uparrow$)

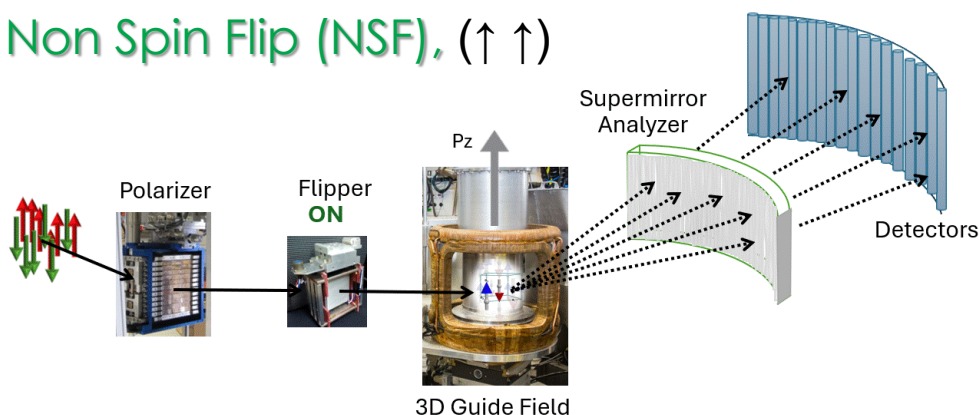

wide angle detector \rightarrow direction of \mathbf{P} with respect to \mathbf{Q} varies significantly as a function of the energy transfer and the detector position

“6-pt method”
(P_X, P_Y, P_Z - SF/NSF)

$$\left(\frac{d\sigma}{d\Omega}\right)_{mag} = 2 \left[\left(\frac{d\sigma}{d\Omega}\right)_{SF}^X + \left(\frac{d\sigma}{d\Omega}\right)_{SF}^Y - 2 \left(\frac{d\sigma}{d\Omega}\right)_{SF}^Z \right]$$

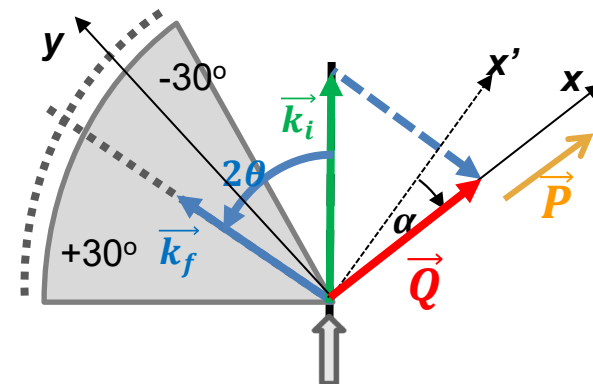

HYSPEC planning tool: Optimize $P_X // Q$:
(Andrei Savici & Kyle Ma)

$$\left(\frac{d\sigma}{d\Omega}\right)_X^{SF} = \frac{1}{2} (\cos^2 \alpha + 1) \left(\frac{d\sigma}{d\Omega}\right)_{mag} + \frac{2}{3} \left(\frac{d\sigma}{d\Omega}\right)_{SI}$$

Strategies:

- Measure all 3 orthogonal fields P_{XYZ} for both SF/NSF
- Measure only $\mathbf{P}_x // \mathbf{Q}$ SF/NSF (for targeted \mathbf{Q} and ΔE).
- Measure only \mathbf{P}_z SF/NSF (no angle correction needed)

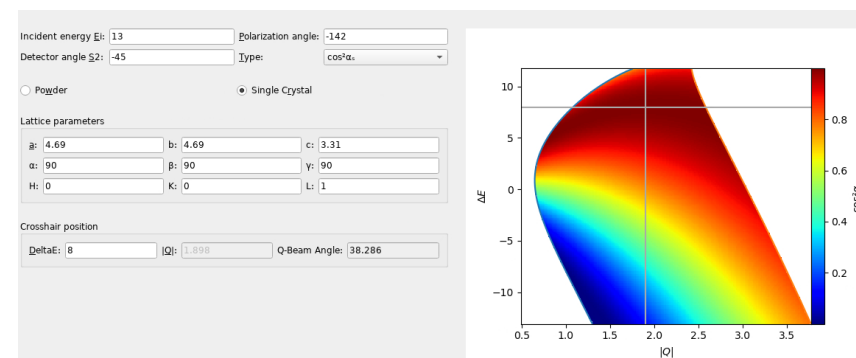

Local dynamical spin correlations in $\text{Fe}_{1+y}\text{Te}_{0.55}\text{Se}_{0.45}$

Yangmu Li, I. Zaliznyak et al. *Nature Materials* (2021)

DOI:[10.1038/s41563-021-00984-7](https://doi.org/10.1038/s41563-021-00984-7)

Superconducting (SC) properties and associated magnetic correlations are highly sensitive to Fe composition.

- ✓ Polarized neutrons with P_x (P//Q) SF/NSF were used to isolate magnetic scattering in two single crystals samples with different Fe content ($\Delta y \approx 0.03$)
- ✓ Depolarization used as order parameter for superconducting transition

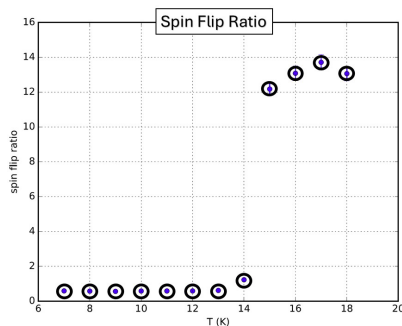

NSC
higher Fe
 $\Delta y \approx 0.03$

SC
 $T_c = 14.5$ K

$5 < E < 7$ meV ($E_i = 20$ meV)

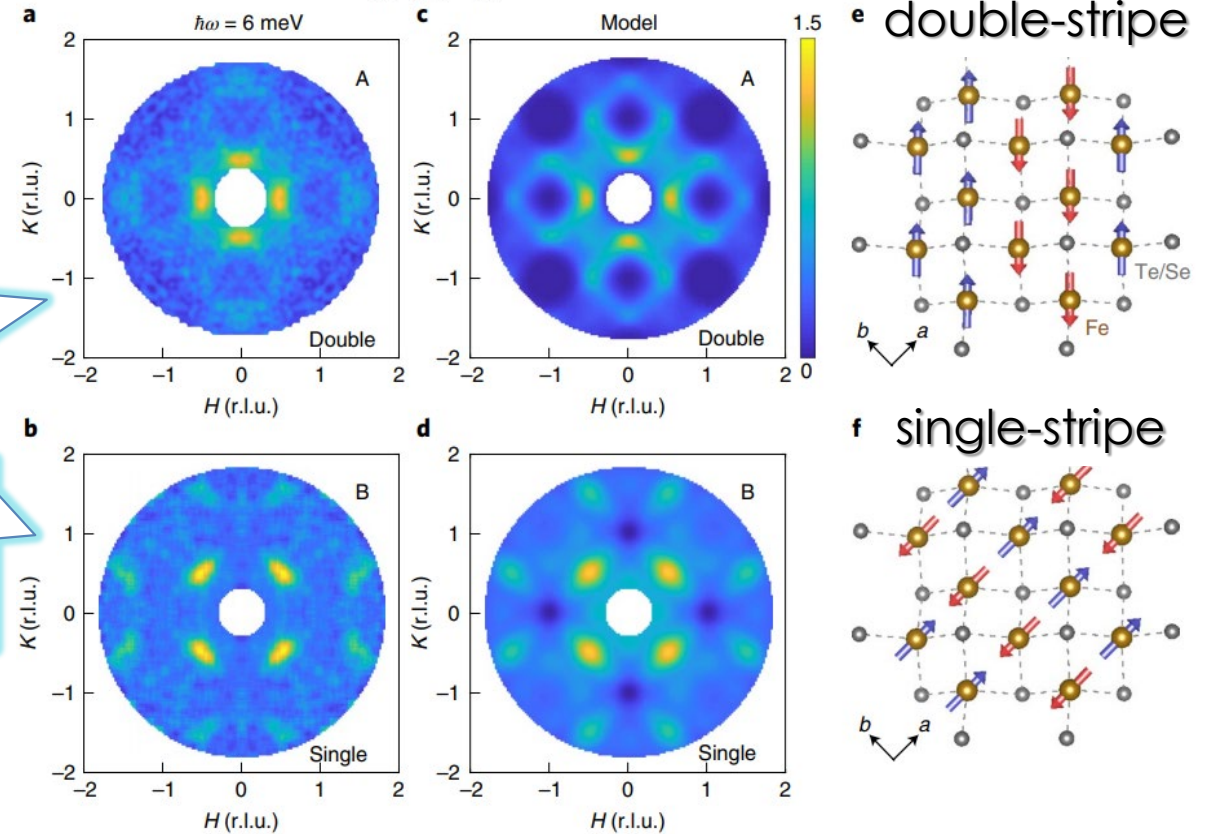

Spin dynamics in 2D square-lattice antiferromagnet $\text{Ba}_2\text{FeSi}_2\text{O}_7$

Seung-Hwan Do, A. Christianson et al. *Nature Comm.* 12, 5331 (2021)
and *npj Quantum Mater.* 8, 5 (2023)

$\text{Ba}_2\text{FeSi}_2\text{O}_7$: easy-plane AFM in the proximity of the QCP ($\alpha = J/D \sim 0.184$)

- ✓ three distinct magnon modes, including two transverse modes (T_1, T_2), and one longitudinal mode (L).
- ✓ Polarized neutrons reveal that T_1 is planar (ab) mode and T_2 is out-of-plane mode. Also demonstrated the decay of the longitudinal mode at the zone center

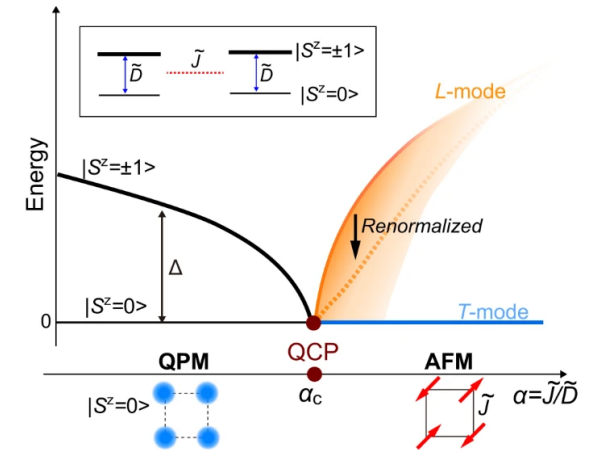
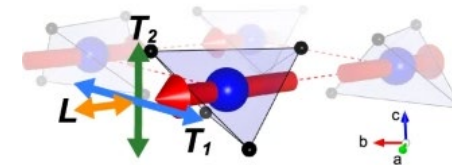

$E_i = 7.5 \text{ meV}$,
(H0L) plane,

Polarized $H = 0 \text{ T}$

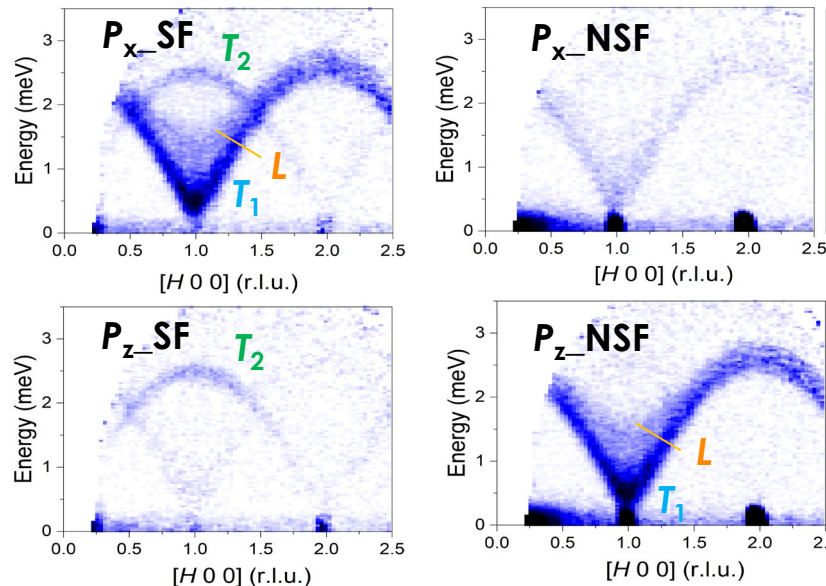

✓ Polarization analysis in applied magnetic fields up to 8 Tesla

8 T unpolarized

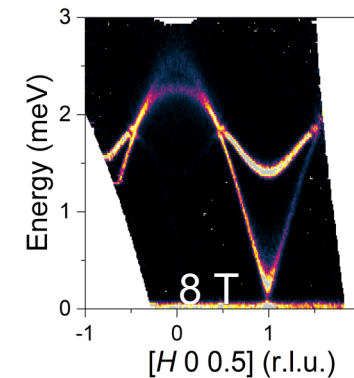

8 T polarized INS

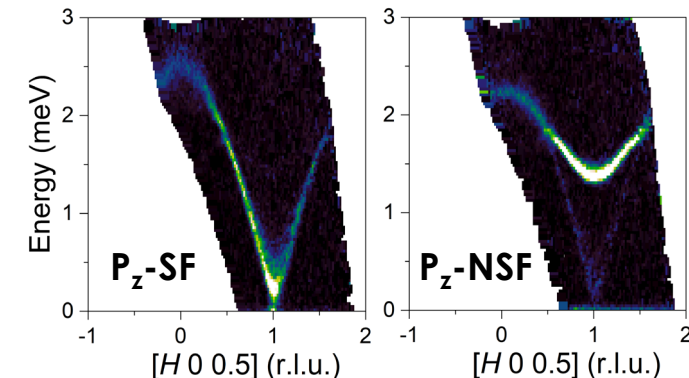

unpolarized

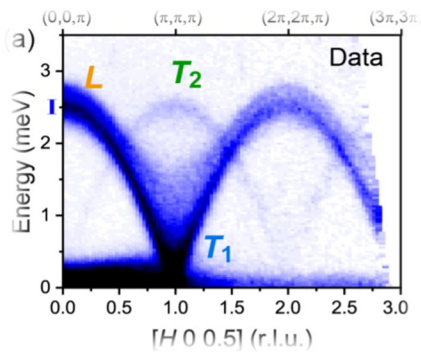

Exploring Kitaev Physics via Field-Dependent Polarization Analysis of a $\text{Na}_3\text{Co}_2\text{SbO}_6$ Honeycomb Layered Oxide

Xintong Li, Yuan Li et al. PRB 109, L060410 (2024) & PRX 12, 041024 (2022)

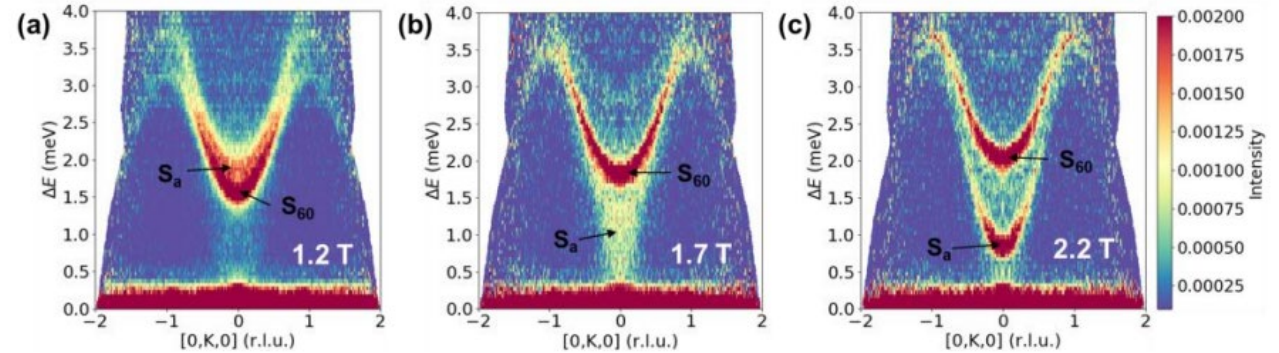
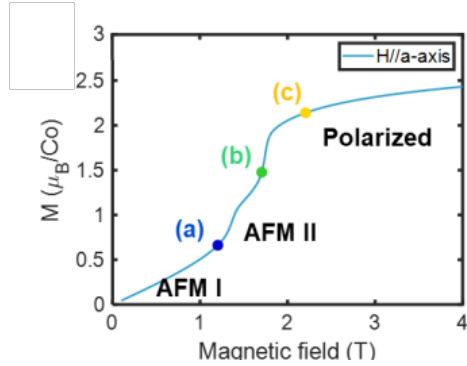
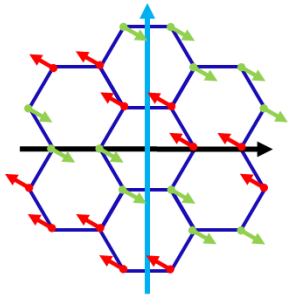

✓ Zig-zag AFM order is altered in two distinct steps by moderate fields $H//a$.

✓ quantum critical point at ~ 1.7 T, accompanied by fractionalized magnetic excitations

unpolarized

Pz SF

Pz NSF



Polarization analysis differentiate:

- soft bosonic modes (mainly NSF),
- transverse spin waves in the polarized state (mainly SF), and
- continuum of fractionalized excitations (visible in both SF and NSF)

Science highlights: XYZ polarization analysis

Separating magnetic diffuse scattering for magnetic-PDF studies

MnTe powder ($T_N = 307\text{K}$)

Ben Frandsen, Raju Baral, Barry Winn, O Garlea,
J. Appl. Phys. 132, 223909 (2022)

Only **Pz** performed for two
detector positions to cover
extended Q range

$E_i = 28\text{meV}$, $Fermi = 60\text{Hz}$
(low energy resolution)

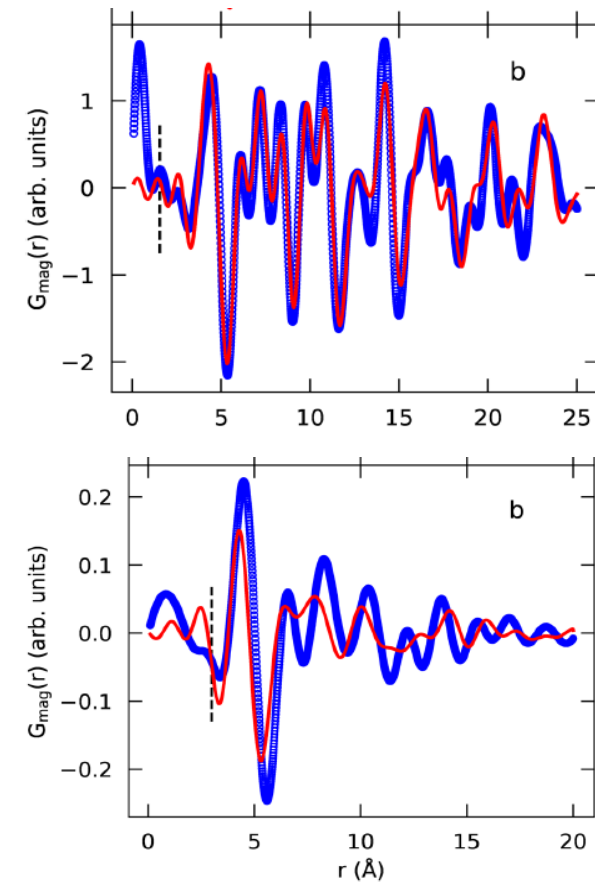
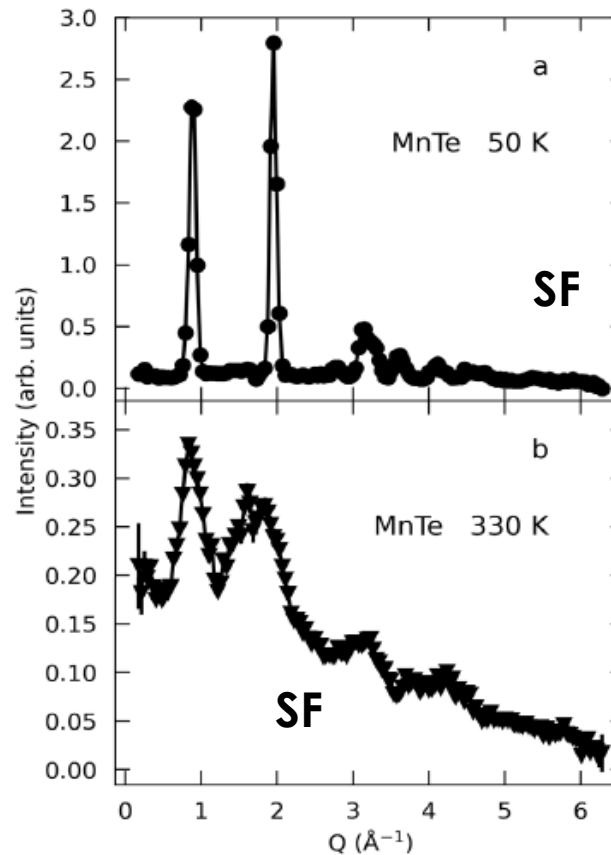
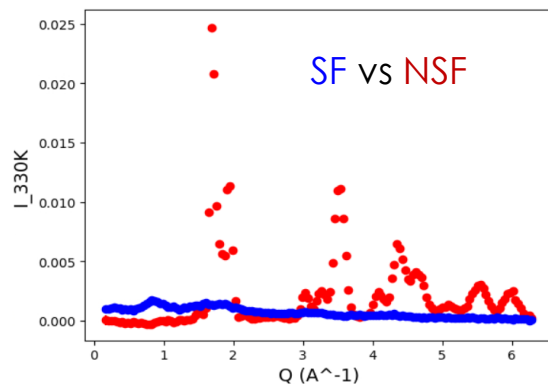

Summary

- Polarized inelastic neutron scattering at HYSPEC provides a powerful probe of magnetic excitations over a large volume of the E-Q space using linear XYZ-polarization analysis
- By combining high-energy-resolution spectroscopy with polarization analysis, HYSPEC enables separation of left- and right-handed magnetic excitations in ferrimagnets and altermagnets.
- HYSPEC offers exceptional operational flexibility, supporting unpolarized, half-polarized, and full XYZ polarization-analysis modes.
- Feasibility discussions with instrument scientists are critical for selecting the appropriate polarization techniques and optics to meet specific experimental requirements.

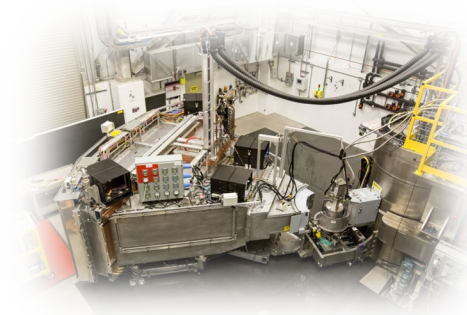

HYSPEC Mail-in Program for powder samples (but no polarization analysis)

<http://neutrons.ornl.gov/hyspec/>

- Mail-in proposals are submitted via IPTS at any time.
- First-come/first-served basis (~10 days /cycle)
- The requested beamtime per proposal can be in 8 hour increments up to 24 hours total.
- 3-powder sample mount for ^3He insert (> 300 mK)

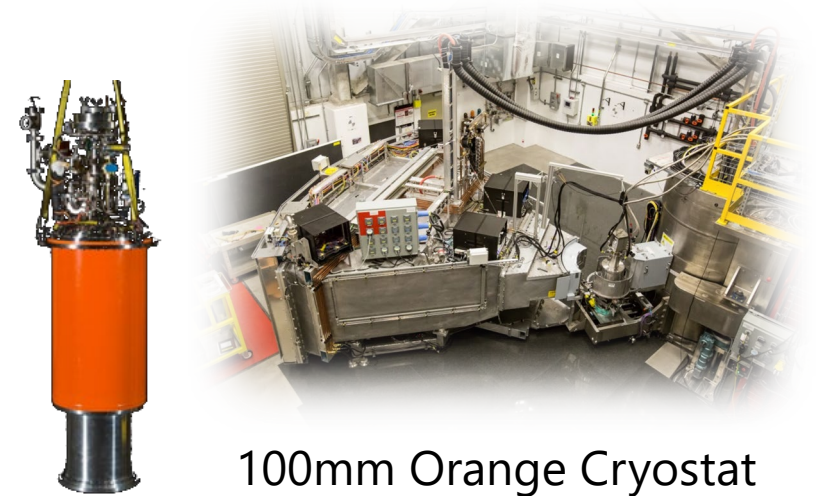

100mm Orange Cryostat
+ 3 sample stick

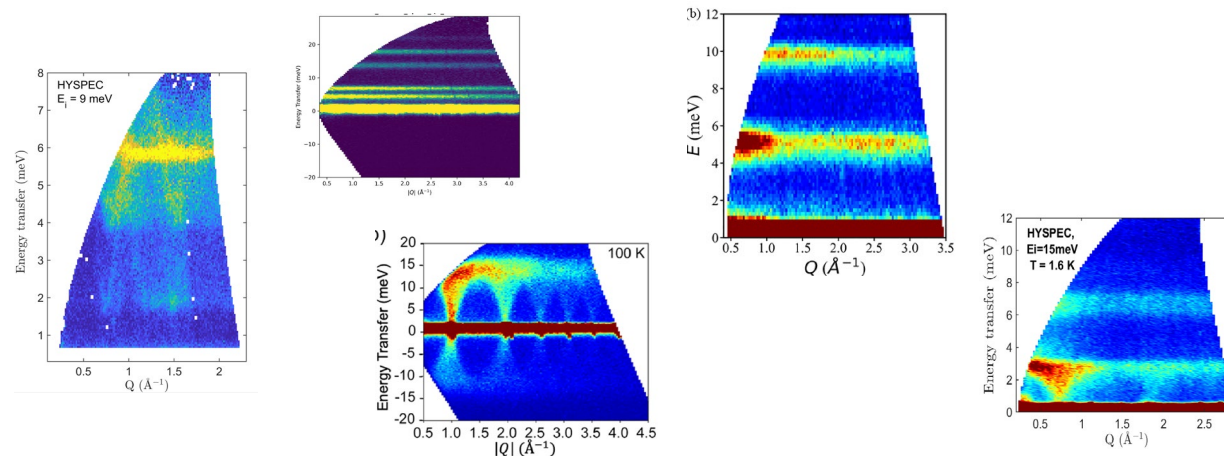

Powder INS can offer rich insight into the spin Hamiltonian, making it a strong complement to powder diffraction.

(HYSPEC, SEQUOIA, ARCS)